



The pump  
of choice  
for the  
food industry



# THE PUMP OF CHOICE FOR THE FOOD INDUSTRY



# The Sine pump principle

- **Gentle pumping action**
- **Virtually pulsation free**
- **High suction**
- **Easy maintenance**

Whether installing in a new plant or seeking to replace an existing pump, MasoSine offers the ideal food and beverage pump to improve your performance and minimize your cost of ownership.

The sinusoidal rotor design of the MasoSine pump delivers lower shear, gentle pumping action that safely transfers delicate food products without risk of degradation. Our pumps provide flows of up to 590 GPM (at 90 psi) and handle pressures of up to 217 psi (at 434 GPM) with no risk to product integrity. Pumping concentrated and viscous products of up to 8 million centipoise (cP) is possible with no damage to the product.

Maintenance takes minutes and can be performed in-place by a line operative. Replace off-the-shelf wear components to restore to “new pump” performance with no need for re-machining or using oversized parts.

All MasoSine pumps carry a 20 year guarantee backed by aftersales and local specialist support from the world leader in Sine pump technology.

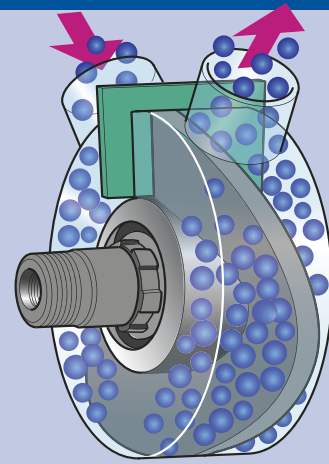

A single sinusoidal rotor creates four evenly sized chambers as it rotates. Fluid is “pulled” through the inlet into each chamber in turn. As the chamber rotates, it contracts, closes then discharges fluid through the outlet port. At the same time, the opposite chamber opens to draw in more fluid, resulting in a smooth flow with virtually no pulsation.

A gate functions as a seal between the inlet and outlet sides of the pump. It prevents pressure equalization and stops fluid escaping from the higher pressure outlet to the low pressure inlet. The sinusoidal rotor rotates within replaceable liners, ensuring no wear to the pump housing or cover.

## Sine pump advantage

**Gentle pumping with virtually no pulsation** – Ultra low shear pumping of whole foods, meats, dairies and concentrates with no loss to product integrity.

**Superior viscous handling** – powerful suction up to 0.85 bar. Products with viscosities from 1 cP to 8 million cP can be transferred with ease.

**Simplicity** – Minimal downtime. One shaft, one seal and no timing gears enable easy in-place pump maintenance.

**Reliability** – 20 year warranty on pump housing and cover.

**Interchangeable parts** – Fully interchangeable components between pumps of the same size, reducing spares inventory.



# FEATURES AND BENEFITS

## Easy maintenance

- One shaft, one rotor and one seal. No complex timing gears
- Replace off-the-shelf wear components to restore to 'new pump' performance
- Easy access for in-place cleaning and maintenance, requiring no special skills or training
- Parts are fully interchangeable between pumps of the same size, reducing spares inventory and simplifying maintenance procedures

## Virtually pulsation free

- Smooth product flow with no need for ancillary dampeners, ensuring process and product quality
- Flow meter accuracy is improved and heat exchanger performance is more efficient

## SPS series

- A range of eight pumps with flow of up to 434 GPM
- Consistent flow with pressures up to 217 psi
- 180° powerframe mounting for easy drainage and maintenance



## Flexible

- Matched to the customer's process requirements and duty fluid
- Port positions available to fit piping requirements, making drop in replacement possible without changing existing pipework
- Pump can run clockwise or counter clockwise
- Stainless steel pump housing, cover and powerframe

## Gentle handling of shear sensitive and whole food products

- Ultra low shear transfer of whole foods, meats, dairy products and concentrates with no risk to product integrity
- Gentle pumping action causes no aeration or foaming during product transfer

## Superior viscous product handling

- Viscous handling from 1 cP to 8 million cP without modification to the pump
- Consistent flow with high suction capability up to 12.3 psi



## EcoSine series

- A range of three pumps with flow of up to 590 GPM
- Consistent flow with pressure up to 87 psi

## Hygienic

- CIP/SIP capability, pump can be cleaned in-place
- FDA, 3A, EHEDG compliance
- Stainless steel pump housing, cover and powerframe

## Low cost of ownership

- Easy access to wear parts enables line side maintenance, completed in minutes by a line operative
- Up to 50% less energy usage for the same flow compared to other pump types

# APPLICATIONS



## ◀ Food products

To deliver a constant feed of whole foods and meats to processing lines, a pump must be capable of handling soft solids in a repeatable manner. MasoSine pumps safely handle products containing soft solids ranging from meat and poultry to salads and vegetables:

- **Low shear, gentle pumping action avoids product damage; maintaining end product quality and delivering high yield rates**
- **Powerful suction with low shear, low pulsation and gentle handling; ideal for delicate product transfer with low noise levels**
- **CIP, SIP or manual cleaning takes minutes and can be performed in-place by a line operative**

## Beverages ▶

Beverage concentrates with acidic and high viscosity properties can make pumping slow and prone to cavitation. The powerful suction of the MasoSine pump transports fluid through the pump without problems:

- **Smooth, laminar flow maintains product stability and ensures greater metering accuracy**
- **Powerful suction reduces cavitation of fluids while increasing flow rates**
- **Reduction in wear lowers maintenance costs and minimizes plant downtime**





## ◀ Dairy products

Transferring shear sensitive cheese curd and whey requires a pump with a gentle pumping action to generate higher yield by lowering the fines content. The MasoSine pump is ideally suited to the transfer of sensitive dairy products:

- A single rotor creates four evenly sized chambers as it rotates producing a gentle pumping action
- The gentle transfer of the product from inlet to discharge reduces fines created, resulting in higher curd yield

## Confectionary ▶

Chocolate, caramel, heavy syrups and liquid sugar are commonplace in confectionary. The MasoSine pump has the ability to gently pump viscous products without risk of damage:

- Virtually pulsation free action for a smooth flow
- Low shear and high suction capability for gentle handling of viscous products
- Cleaning is a simple process that can be performed quickly, ready for the next product run
- The addition of a heating or cooling jacket ensures optimal temperature control for your process



# TECHNICAL SPECIFICATIONS

## Performance curves

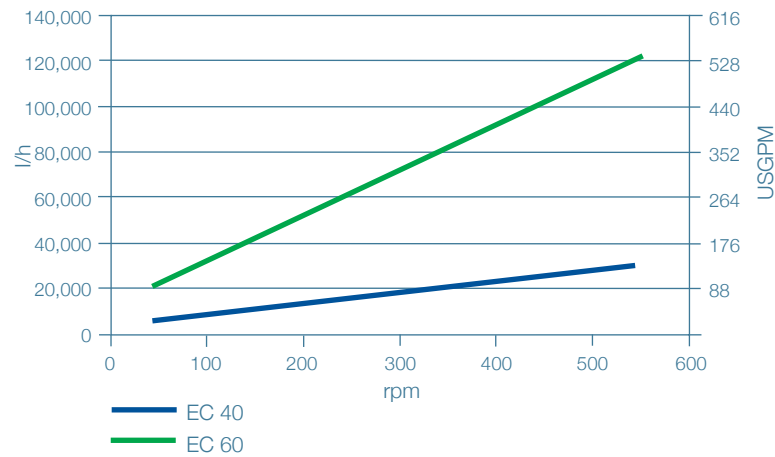
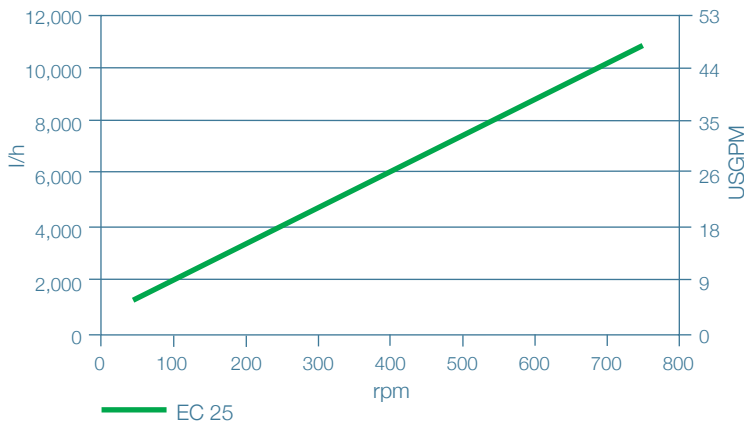
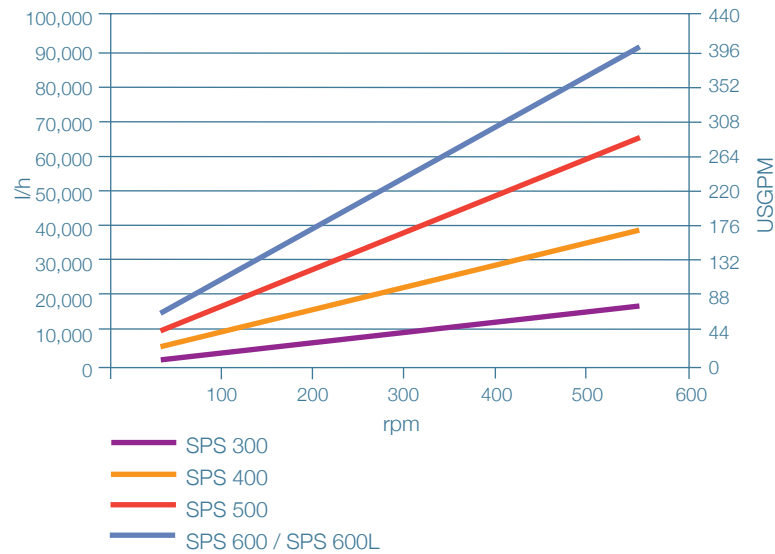
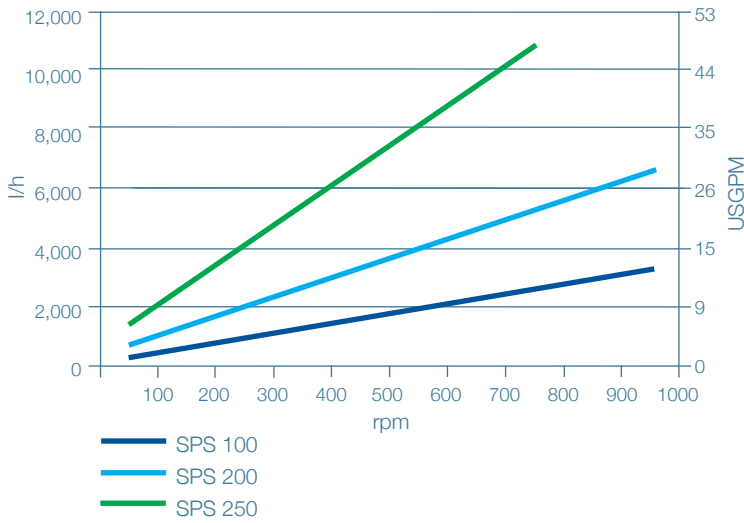

## Technical data

Model	Maximum particle size		Volume per revolution		Speed	Maximum flow		Maximum pressure		Maximum temperature	
	mm	inch	liter	US gallons	rpm	l/h	US gal/min	bar	psi	C	F
SPS 100	10	0.39	0.08	0.021	1,000	4,800	21.1	10	145	180	356
SPS 200	20	0.79	0.13	0.034	1,000	7,800	34.2	10	145	180	356
SPS 250	22	0.87	0.24	0.063	800	11,520	50.5	15	217	180	356
SPS 300	30	1.18	0.50	0.132	600	18,000	78.9	15	217	180	356
SPS 400	48	1.89	1.16	0.305	600	41,760	183.2	15	217	180	356
SPS 500	50	1.97	1.92	0.505	600	69,120	303.2	15	217	180	356
SPS 600	60	2.36	2.75	0.724	600	99,000	434.2	15	217	180	356
SPS 600L	60	2.36	2.75	0.724	600	99,000	434.2	15	217	180	356
EC-25	22	0.87	0.24	0.063	800	11,520	50.5	6	87	95	200
EC-40	36	1.42	0.94	0.247	600	33,840	148.4	6	87	95	200
EC-60	60	2.36	3.74	0.984	600	134,640	590.5	6	87	95	200



# Dimensions

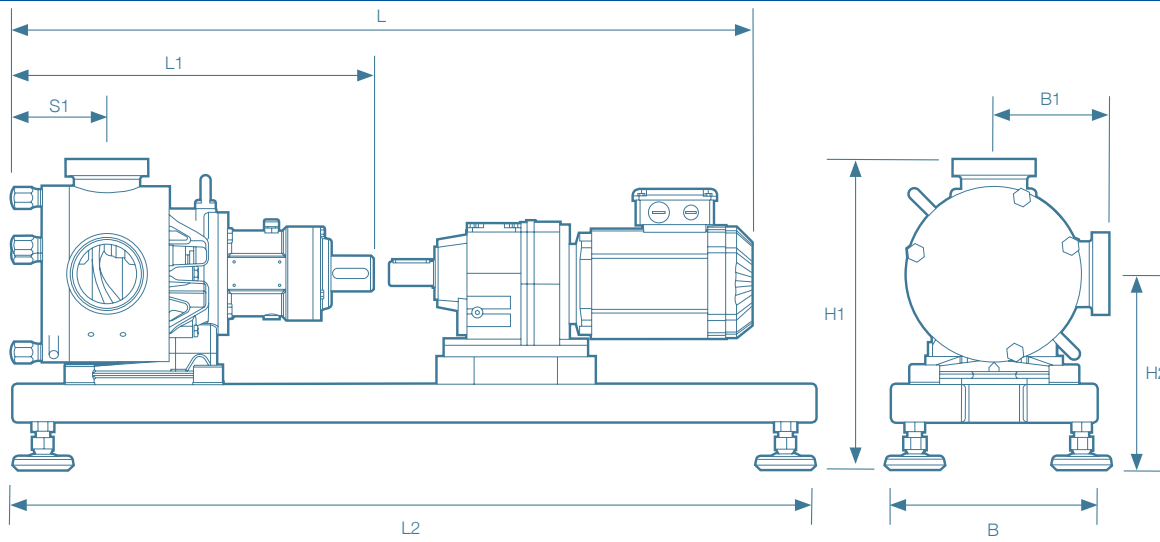

Model	L		L1		L2		S1		B		B1		H1		H2									
	min.	max.									min.	max.	min.	max.	min.	max.								
	mm	inch	mm	inch	mm	inch	mm	inch	mm	inch	mm	inch	mm	inch	mm	inch	mm	inch	mm	inch	mm	inch		
SPS 100	735	28.9	860	33.9	292	11.5	800	31.5	89	3.5	210	8.3	97	3.8	121	4.8	300	11.8	330	13.0	202	8.0	232	9.1
SPS 200	740	29.1	960	37.8	345	13.6	800	31.5	95	3.7	210	8.3	106	4.2	137	5.4	314	12.4	344	13.5	208	8.2	238	9.4
SPS 250	872	34.3	1,091	43	428	16.9	800	31.5	114	4.5	210	8.3	126	4.96	156	6.14	375	14.8	445	17.5	250	9.84	290	11.4
SPS 300	985	38.8	1,382	54.4	492	19.4	1,100	43.3	128	5.0	280	11.0	156	6.1	182	7.2	426	16.8	490	19.3	270	10.6	310	12.2
SPS 400	1,235	48.6	1,805	71.1	619	24.4	1,300	51.2	169	6.7	380	15.0	192	7.6	208	8.2	505	19.9	567	22.3	318	12.5	358	14.1
SPS 500	1,300	51.2	1,640	64.6	659	25.9	1,300	51.2	131	5.16	380	15	212	8.35	235	9.25	560	22	623	24.5	348	13.7	388	15.3
SPS 600	1,755	69.1	2,200	86.6	771	30.4	1,400	55.1	319	12.6	400	15.8	274	10.8	274	10.8	630	24.8	700	27.6	353	13.9	433	17.1
SPS 600L	1,302	51.3	2,100	82.7	686	27.0	1,400	55.1	234	9.2	400	15.8	270	10.6	274	10.8	675	26.2	757	29.8	390	13.4	487	19.2

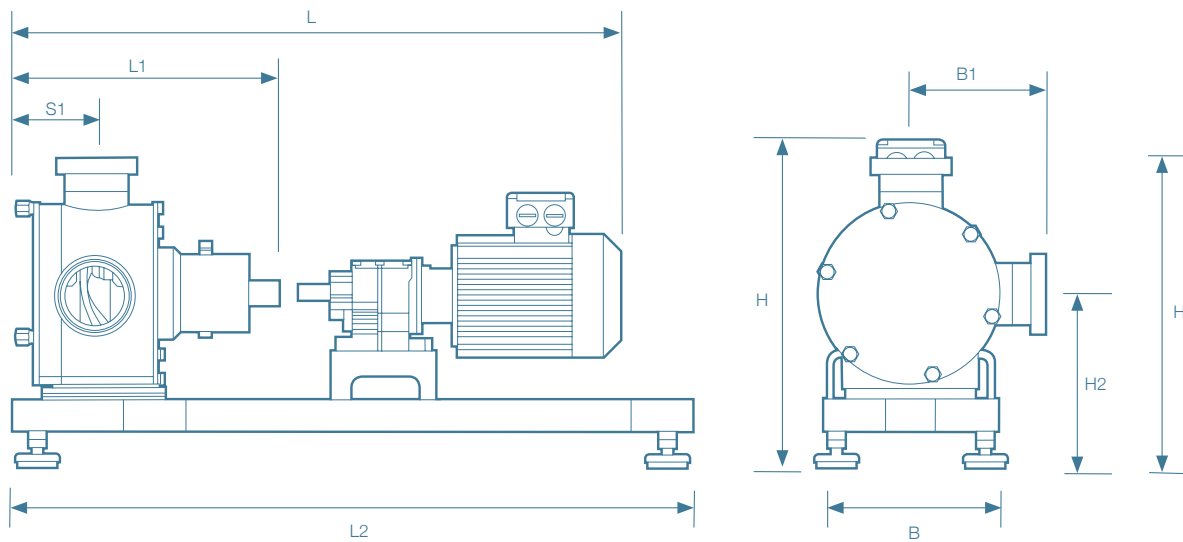

Model	L		L1		L2		S1		B		B1		H		H1		H2											
	min.	max.									min.	max.	min.	max.	min.	max.	min.	max.										
	mm	inch	mm	inch	mm	inch	mm	inch	mm	inch	mm	inch	mm	inch	mm	inch	mm	inch	mm	inch	mm	inch						
EC-25	832	32.8	915	36.0	340	13.4	800	31.5	105	4.1	210	8.3	132	5.2	160	6.3	384	15.1	460	18.1	395	15.6	395	15.6	233	9.2	233	9.2
EC-40	983	38.7	1,068	42.1	432	17.0	1,100	43.3	136	5.4	280	11.1	181	7.1	220	8.7	454	17.9	548	21.6	470	18.5	508	20.0	288	11.3	288	11.3
EC-60	1,305	51.4	1,701	67.0	675	26.6	1,355	53.4	212	8.4	380	15.0	295	11.6	315	12.4	638	25.1	765	30.1	645	25.4	665	26.2	350	13.8	350	13.8

# OPTIONS AND ACCESSORIES



## Connection ports

MasoSine pumps are available with ports to suit your application including tri-clamp or bevel seat connections as standard. Customized connection including DIN, SMS, ANSI 150# RF are also available on request.

## Port orientation

Pumps can be configured with ports in a range of orientations to meet installation requirements. Customized port orientations are also possible upon request.



## Ensuring the correct temperature for your process

A jacketing system is available to allow pumps to be heated or cooled to the optimal temperature for your process, for example when pumping chocolate or ice cream.

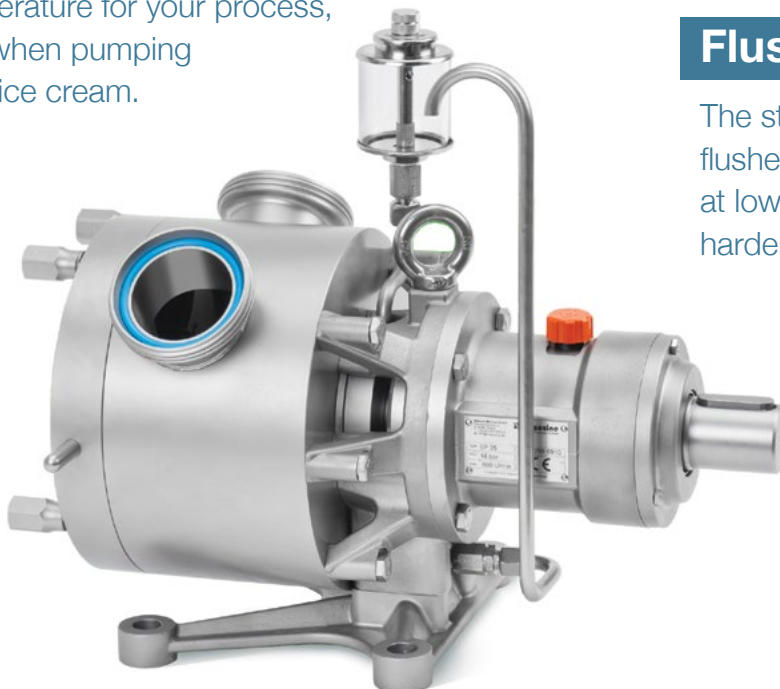

## Flush systems

The static and dynamic flush system flushes the area behind the seal system, at low pressure, to prevent product from hardening and damaging the seal system.

# SERVICE AND SUPPORT

## Service

We believe in providing the highest standard of service to our customers, at every level. We work with them to understand their applications and pressures affecting their business, and provide solutions that are specifically matched to their requirements.

## Support

Customer support is provided through a network of Sine pump specialists and technical support teams. This ensures our customers always benefit from local knowledge and MasoSine pump expertise. No matter where your business operates, MasoSine is never far away.

## Genuine spares

MasoSine's approved parts policy means only the highest quality materials are used in the manufacture of our pumps. This gives our customers confidence that our pumps will not let them down.

Essential spare parts can be dispatched on the day the order is received. Standard pumps can be dispatched within 24 hours.

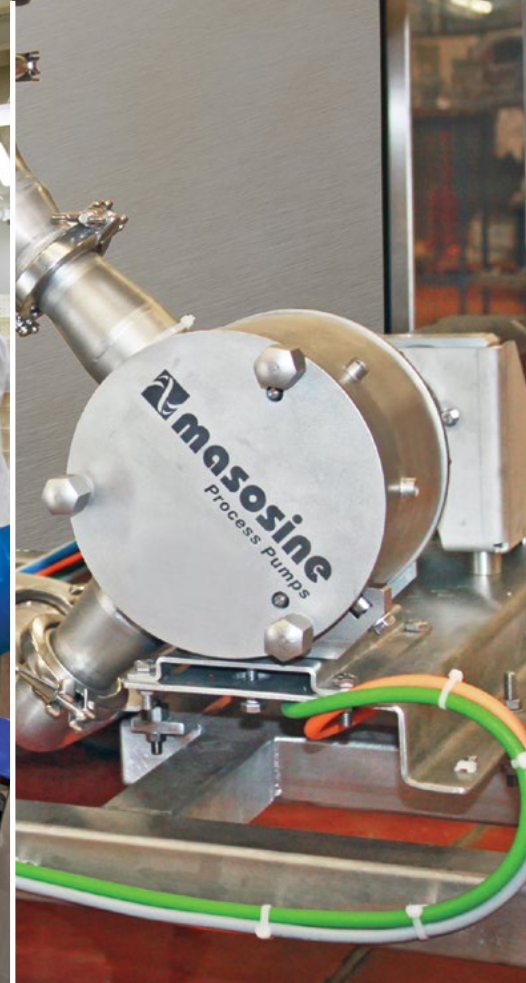



Watson-Marlow Pumps Group

A Spirax-Sarco Engineering Company

Watson-Marlow Pumps Group has seven world-class factories supported by direct sales operations in 24 countries and distributors in more than 50 countries.

For contact details visit our website:

[www.wmpg.com](http://www.wmpg.com)

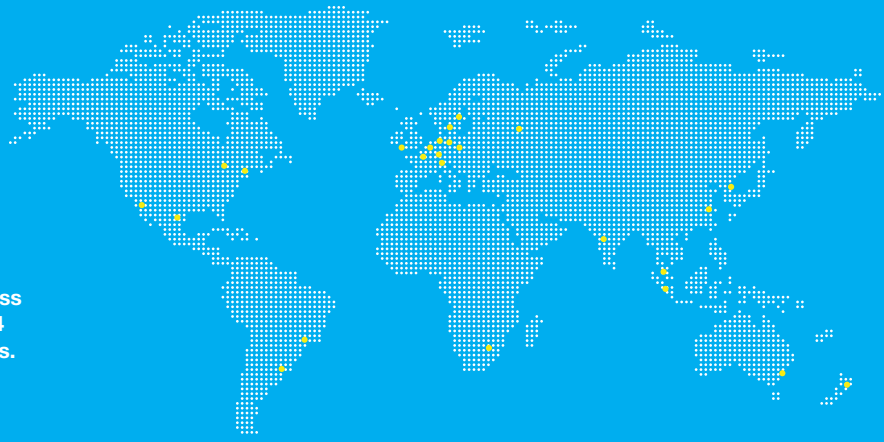

Watson-Marlow

Bredel

Flexicon

MasoSine

BioPure



## Watson-Marlow online

Our engineers around the world can help you choose the perfect pump and tubing for your needs.

More information? Our brochures are on our website - [www.wmpg.com](http://www.wmpg.com)

[support@wmpg.us](mailto:support@wmpg.us)

*Watson-Marlow... Innovation in Full Flow*

### Watson-Marlow Pumps Group

Watson-Marlow, Inc.  
37 Upton Technology Park  
Wilmington, MA 01887  
Tel: 800-282-8823

Watson-Marlow, Inc. (West)  
20992 Bake Parkway, Suite 100  
Lake Forest, CA 92630  
Tel: 855-567-9674

The information in this document is believed to be correct, but Watson-Marlow Pumps Group accepts no liability for any errors it contains, and reserves the right to alter specifications without notice. Watson-Marlow is a registered trademark of Watson-Marlow Limited.