

FLENDER COUPLINGS
CATALOG **FLE 10.4**
EDITION 2020 EN



FLUID COUPLINGS
FLUDEX

FLE 10 CATALOG GROUP



Product catalog FLE 10.1
Torsionally Rigid Couplings



Product catalog FLE 10.3
Highly Flexible Couplings



Product catalog FLE 10.2
Flexible Couplings



Product catalog FLE 10.4
Fluid Couplings

For further coupling catalogs, see page A/6

FLUID COUPLINGS



Catalog FLE 10.4 Edition 2020 EN

Introduction

Torsionally Rigid Gear Couplings ZAPEX ZW

ZAPEX ZN

Torsionally Rigid All-Steel Couplings N-ARPEX, ARPEX

Flexible Couplings

N-EUPEX

RUPEX

N-BIPEX

Highly Flexible Couplings

ELPEX-B

ELPEX-S

ELPEX

Fluid Couplings

FLUDEX

Appendix

E

4

5

6

7

8

9

10

11

12

13

A

INTRODUCTION

E

The mechanical drive train comprises individual units such as motor, gear unit and driven machine. The coupling connects these component assemblies.

As well as the transmission of rotary motion and torque, other requirements may be made of the coupling.

- Compensation for shaft misalignment with low restorative forces
- Control of characteristic angular vibration frequency and damping
- Interruption or limitation of torque
- Noise insulation, electrical insulation

Couplings are frequently chosen after the machines to be connected have already been selected. Thanks to a large number of different coupling assembly options, specified marginal conditions for clearance and connection geometry can be met from the standard range. The coupling also performs secondary functions, e.g. providing a brake disk or brake drum for operating or blocking brakes, devices to record speed or the attachment of sprockets or pulleys.

Couplings are divided into two main groups, couplings and clutches.

Clutches interrupt or limited the transmissible torque. The engaging and disengaging forces on externally operated clutches are introduced via a mechanically, electrically, hydraulically or pneumatically operating mechanism. Overload, centrifugal or freewheel clutches draw their engaging energy from the transmitted output.

Rigid couplings, designed as clamp, flanged or mechanism couplings, connect machines which must not undergo any shaft misalignment. Hydrodynamic couplings, often also called fluid or Föttinger couplings, are used as starting couplings in drives with high mass moments of inertia of the driven machine. In drive technology very often flexible, positive couplings, which may be designed to be torsionally rigid, torsionally flexible or highly flexible, are used.

Torsionally rigid couplings are designed to be rigid in a peripheral direction and flexible in radial and axial directions. The angle of rotation and torque are conducted through the coupling without a phase shift.

Torsionally flexible couplings have resilient elements usually manufactured from elastomer materials. Using an elastomer material with a suitable ShoreA hardness provides the most advantageous torsional stiffness and damping for the application. Shaft misalignment causes the resilient elements to deform.

Highly flexible couplings have large-volume (elastomer) resilient elements of low stiffness. The angle of rotation and torque are conducted through the coupling with a considerable phase shift.

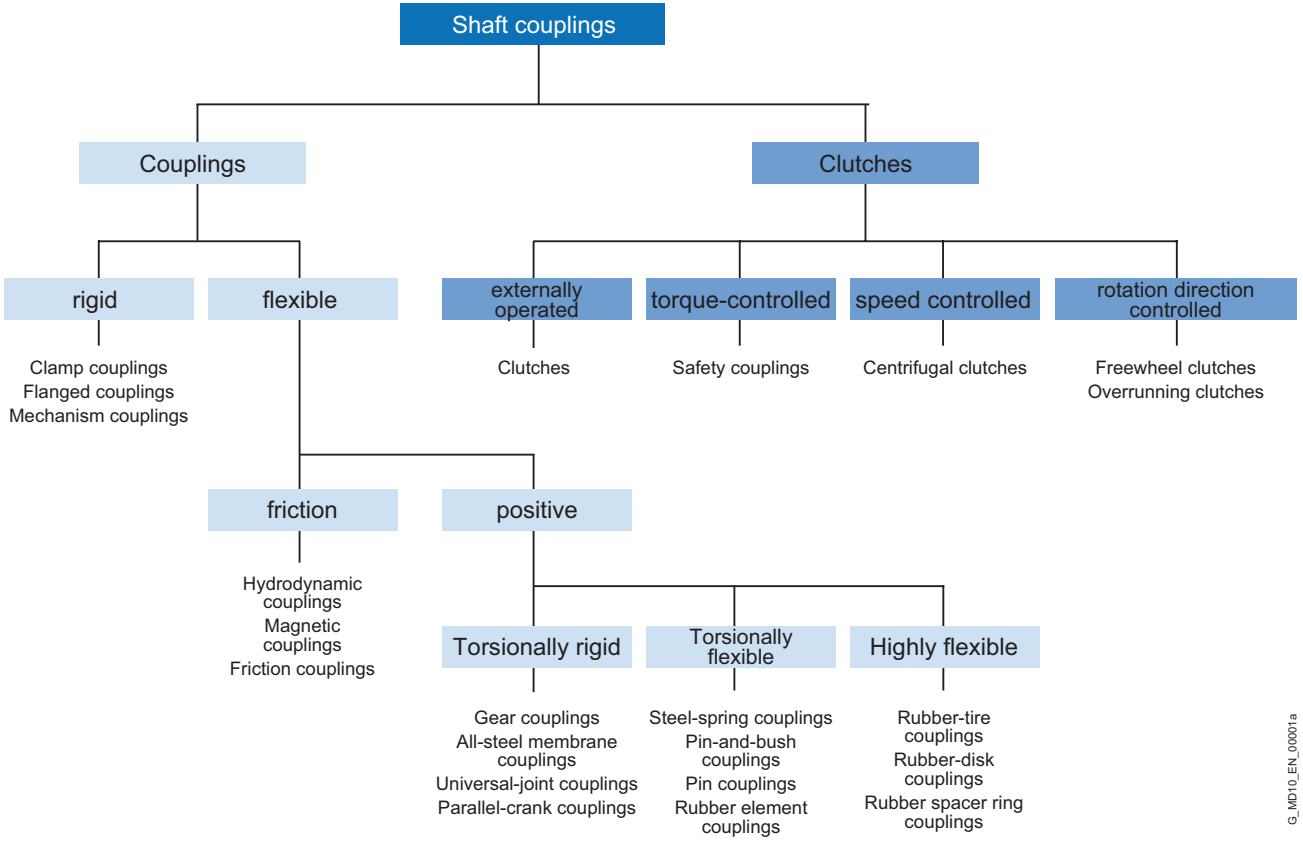

G_IMD10_EN_00001a

OUR COUPLING GROUPS AT A GLANCE

E

N-EUPEX, RUPEX and N-BIPEX

Flexible Couplings

Flexible Flender couplings have a wide range of possible applications. A broad standard modular system as well as specially designed application-specific couplings are available.

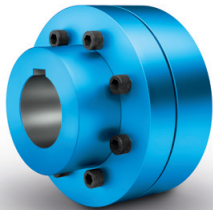

N-EUPEX
cam couplings
Rated torque:
19 Nm ... 62,000 Nm

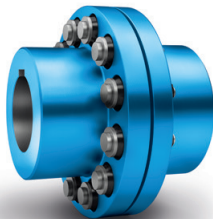

RUPEX
pin-and-bush couplings
Rated torque:
200 Nm ... 1,300,000 Nm



N-BIPEX
cam couplings
Rated torque:
12 Nm ... 4,650 Nm

ELPEX, ELPEX-B and ELPEX-S

Highly Flexible Couplings

ELPEX® couplings are free of circumferential back-lash. Their damping capacity and low torsional stiff-ness make them especially well-suited for coupling machines with strongly non-uniform torque characteristics or large shaft misalignment.

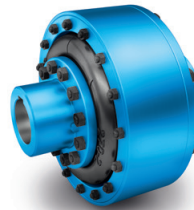

ELPEX
elastic ring couplings
Rated torque:
1,600 Nm ... 90,000 Nm



ELPEX-B
elastic tire couplings
Rated torque:
24 Nm ... 14,500 Nm



ELPEX-S
rubber disk couplings
Rated torque:
330 Nm ... 63,000 Nm

ZAPEX gear couplings and ARPEX all-steel couplings

Torsionally rigid couplings

For transmission of high torques, we offer both ARPEX all-steel couplings and ZAPEX gear couplings in a range of versions. Their purposes of application vary according to specific requirements with respect to shaft misalignment, temperature and torque.

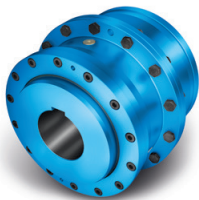

ZAPEX
gear couplings
Rated torque:
1,300 Nm ... 7,200,000 Nm



ARPEX
high Performance Couplings
Rated torque:
1,000 Nm ... 588,500 Nm



N-ARPEX and ARPEX
all-steel couplings
Rated torque:
92 Nm ... 2,000,000 Nm

BIPEX-S and SIPEX

Backlash-free couplings

The vibration-damping, electrically insulating plug-in BIPEX-S elastomer couplings and SIPEX metal bellows couplings with very high torsional stiffness deliver especially isogonal torque transmission.

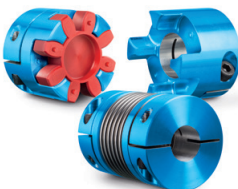

BIPEX-S and SIPEX
Rated torque:
0.1 Nm ... 5,000 Nm

FLUDEX

Hydrodynamic couplings

The FLUDEX hydrodynamic fluid coupling works according to the Föttinger principle. It functions entirely free of wear.



FLUDEX
fluid Couplings
Power:
1.2 kW ... 2,500 kW

Application-specific couplings

Couplings for rail vehicles must meet high demands. Due to their high degree of standardization and wide variety, they can be used in the most diverse vehicle types.

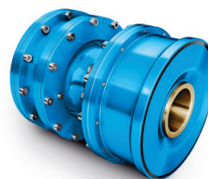

Railway coupling
Rated torque:
1,000 Nm ... 9,500 Nm

Each wind turbine coupling is designed to optimally meet the requirements of the respective wind turbine. The coupling connects the fast-running gear shaft with the generator shaft and is available for wind turbines with a capacity of up to 12 MW.

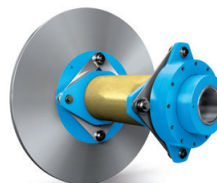

Wind turbine couplings
Rated torque:
10,000 Nm ... 60,000 Nm

TECHNICAL INFORMATION AND COUPLING SELECTION

Technical Information	E/8
Shaft misalignment	E/8
Balancing	E/9
Shaft-hub connections	E/11
Standards	E/12
Key to symbols	E/13
<hr/>	
Selection of the coupling series	E/14
Typical coupling solutions for different example applications	E/15
<hr/>	
Selection of the coupling size	E/16
Coupling load in continuous operation	E/16
Coupling load at maximum and overload conditions	E/17
Coupling load due to dynamic torque load	E/17
Checking the maximum speed	E/18
Checking permitted shaft misalignment	E/18
Checking bore diameter, mounting geometry and coupling design	E/18
Coupling behavior under overload conditions	E/18
Checking shaft-hub connection	E/18
Checking low temperature and chemically aggressive environment	E/18
<hr/>	
Features of the standard type	E/19
<hr/>	

TECHNICAL INFORMATION

E

Shaft misalignment

Shaft misalignment is the result of displacement during assembly and operation and, where machines constructed with two radial bearings each are rigidly coupled, will cause high loads being placed on the bearings. Elastic deformation of base frame, foundation and machine housing will lead to shaft misalignment which cannot be prevented, even by precise alignment.

Furthermore, because individual components of the drive train heat up differently during operation, heat expansion of the machine housings causes shaft misalignment. Poorly aligned drives are often the cause of seal, rolling bearing or coupling failure. Alignment should be carried out by specialist personnel in accordance with operating instructions.

Depending on the direction of the effective shaft misalignment a distinction is made between:

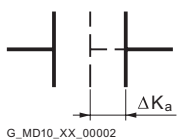

Axial misalignment

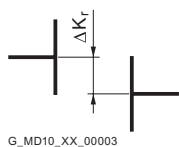

Radial misalignment

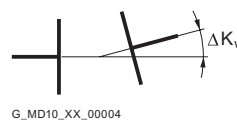

Angular misalignment

Couplings can be categorized into one of the following groups:

Single-joint couplings

Couplings with flexible elements mainly made of elastomer materials. Shaft misalignment results in deformation of the elastomer elements. The elastomer elements can absorb shaft misalignment as deformations in an axial, radial and angular direction. The degree of permissible misalignment depends on the coupling size, the speed and the type of elastomer element.

Single-joint couplings do not require an adapter and are therefore short versions.

Example:

In the case of a RUPLEX RWN 198 coupling with an outer diameter of 198 mm and a speed of 1500 rpm, the permitted radial misalignment is $\Delta K_r = 0.3$ mm.

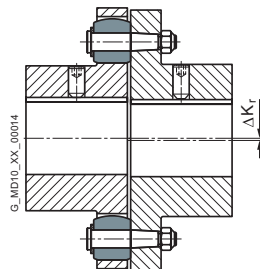

Two-joint couplings

Two-joint couplings are always designed with an adapter. The two joint levels are able to absorb axial and angular misalignment. Radial misalignment occurs via the gap between the two joint levels and the angular displacement of the joint levels. The permitted angular misalignment per joint level is frequently about 0.5° . The permitted shaft misalignment of the coupling can be adjusted via the length of the adapter. If there are more than two joint levels, it is not possible to define the position of the coupling parts relative to the axis of rotation. (The less frequently used parallel-crank couplings are an exception).

Example:

N-ARPEX ARN-6 NEN 217-6 with a shaft distance of 140 mm with a permitted radial misalignment of $\Delta K_r = 2.2$ mm [angle per joint level 1.0°].

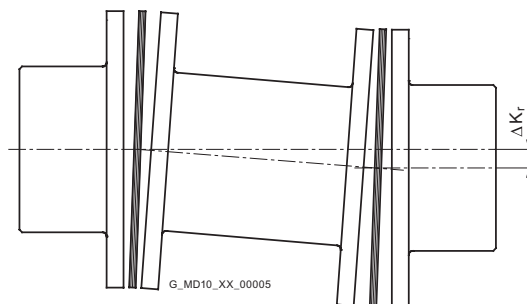

Balancing

Balance quality levels

The so-called quality level G to DIN ISO 21940 indicates a range of permitted residual imbalance from zero up to an upper limit. Applications can be grouped on the basis of similarity analysis. For many applications a coupling balance quality of G 16 is sufficient. On drives susceptible to vibration the balance quality should be G 6.3. Only in special cases is a better balance quality required.

Balancing standard in accordance with DIN ISO 21940-32

Besides the required balance quality, it is necessary to set standards which define how the mass of the parallel key is to be taken into consideration when balancing. In the past, motor rotors have frequently been balanced in accordance with the full parallel key standard. The "appropriate" balance condition of the coupling hub was described as "balancing with open keyway" or "balancing after keyseating". Today it is usual for the motor rotor, as well as the gear unit and driven machine shaft, to be balanced in accordance with the half parallel key standard.

Full parallel key standard

The parallel key is inserted in the shaft keyway, then balancing is carried out. The coupling hub must be balanced without parallel key after keyseating.

Marking of shaft and hub with "F" (for "full").

Half parallel key standard

The balancing standard normally applied today. Before balancing, a half parallel key is inserted in the shaft and another in the coupling hub. Alternatively, balancing can be carried out before cutting the keyway.

The balanced parts must be marked with an "H". This marking can be dispensed with if it is absolutely clear which parallel key standard has been applied.

No parallel key standard

Balancing of shaft and coupling hub after keyseating, but without parallel key. Not used in practice. Marking of shaft and hub with "N" (for "no").
The length of the parallel key is determined by the shaft keyway. Coupling hubs may be designed considerably shorter than the shaft.

To prevent imbalance forces caused by projecting parallel key factors when balancing in accordance with the half parallel key standard in the case of applications with high balancing quality requirements, grooved spacer rings can be fitted or stepped parallel keys used.

Flender Balancing Standard

The balancing quality level, together with the operating speed, results in the maximum permissible eccentricity of the center of gravity of the coupling or the coupling subassembly. In the Flender article number the balancing quality can be preset with the help of the order code. Additionally, also the balance quality level to DIN ISO 21940 can be preset together with the operating speed belonging to it, which then be taken as priority.

$$e_{perm} = 9550 \cdot \frac{G}{n}$$

$$e_{coupl} \leq e_{perm}$$

Permitted eccentricity of center of gravity e_{perm} in μm
 Eccentricity of center of gravity of coupling e_{coupl} in μm
 Balancing quality level G in mm/s
 Coupling speed n in rpm

Eccentricity of center of gravity of coupling e_{coupl}	Flender balancing quality	Order code
maximum 100 μm	standard balancing	without specification
maximum 40 μm	fine balancing	W02
maximum 16 μm	micro-balancing	W03
better than 16 μm	special balancing	on request

TECHNICAL INFORMATION

E

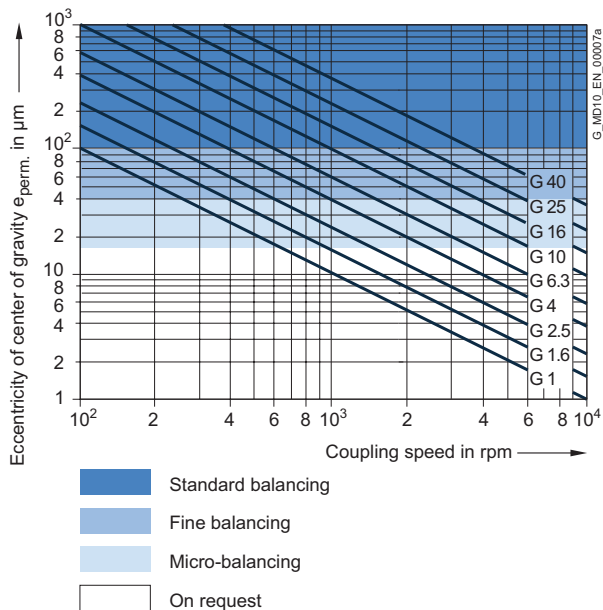

Example:
Coupling speed = 1450 rpm
required balancing quality level G 6.3

$$e_{perm} = 9550 \cdot \frac{G}{n} = 9550 \cdot \frac{6.3}{1450} \mu\text{m}$$

Thus, the required eccentricity of center of gravity is 41.5 μm. The fine balancing with a maximum eccentricity of center of gravity of 40 mm fulfills this requirement; therefore, the order code W02 has to be specified when ordering.

For many applications the following balancing quality recommendation applies:

Coupling	standard balancing $v = DA \cdot n/19100$	fine balancing
short version with $LG \leq 3 \times DA$	$v < 30 \text{ m/s}$	$v > 30 \text{ m/s}$
long version with $LG > 3 \times DA$	$v \leq 15 \text{ m/s}$	$v > 15 \text{ m/s}$

Peripheral speed	v	in mm/s
Coupling outer diameter	DA	in mm
Coupling speed	n	in rpm
Coupling length	LG	in mm

The following standards on balancing must be observed:

- couplings are balanced in subassemblies.
- hub parts without finished bore are unbalanced.
- the number of balancing levels (one- or two-level balancing) is specified by Flender.
- without special specification balancing is done in accordance with the half-parallel-key standard. Balancing in accordance with the full-parallel-key standard must be specified in the order number.
- For FLUDEX couplings special balancing standards specified in Section 13 apply.
- ARPEX couplings in standard balancing quality are unbalanced. Thanks to steel components machined all over and precisely guided adapters the balancing quality of standard balancing is nearly always adhered to.

Shaft-hub connections

The bore and the shaft-hub connection of the coupling are determined by the design of the machine shaft. In the case of IEC standard motors, the shaft diameters and parallel key connections are specified in accordance with DIN EN 50347. For diesel motors, the flywheel connections are frequently specified in accordance with SAE J620d or DIN 6288. Besides the very widely used connection of shaft and hub with parallel keys to DIN 6885 and cylindrically bored hubs, couplings with Taper clamping bushes, clamping sets, shrink-fit connections and splines to DIN 5480 are common.

The form stability of the shaft/hub connection can only be demonstrated when shaft dimensions and details of the connection are available. The coupling torques specified in the tables of power ratings of the coupling series do not apply to the shaft-hub connection unrestrictedly.

In the case of the shaft-hub connection with parallel key, the coupling hub must be axially secured, e.g. with a set screw or end washer. The parallel key must be secured against axial displacement in the machine shaft.

All Flender couplings with a finished bore and parallel keyway are designed with a set screw. Exceptions are some couplings of the FLUDEX series, in which end washers are used. During assembly, Taper clamping bushes are frictionally connected to the machine shaft.

TECHNICAL INFORMATION

E

Standards

Machines

2006/42/EG	EC Machinery Directive
2014/34/EU	ATEX Directive – Manufacturer
1999/92/EG	ATEX Directive – Operator – and ATEX Guideline to Directive 1999/92/EC
DIN EN 80079-36	Non-electrical equipment for use in potentially explosive atmospheres
DIN EN 1127	Explosive atmospheres, explosion prevention and protection
DIN EN 50347	General-purpose three-phase induction motors having standard dimensions and outputs

Couplings

DIN 740	Flexible shaft couplings Part 1 and Part 2
VDI Guideline 2240	Shaft couplings - Systematic subdivision according to their properties VDI Technical Group Engineering Design 1971
API 610	Centrifugal Pumps for Petroleum, Chemical and Gas Industry Services
API 671	Special Purpose Couplings for Petroleum, Chemical and Gas Industry Services
ISO 10441	Petroleum, petrochemical and natural gas industries – Flexible couplings for mechanical power transmission-special-purpose applications
ISO 13709	Centrifugal pumps for petroleum, petrochemical and natural gas industries

Balancing

DIN ISO 21940	Requirements for the balancing quality of rigid rotors
DIN ISO 21940-32	Mechanical vibrations; standard governing the type of parallel key during balancing of shafts and composite parts

Shaft-hub connections

DIN 6885	Driver connections without taper action – parallel keys – keyways
SAE J620d	Flywheels for industrial engines ...
DIN 6288	Reciprocating internal combustion engines Dimensions and requirements for flywheels and flexible couplings
ASME B17.1	Keys and keyseats
DIN EN 50347	General-purpose three-phase induction motors with standard dimensions and output data
BS 46-1:1958	Keys and keyways and taper pins Specification

Key to symbols

Name	Symbols	Unit	Explanation
Torsional stiffness, dynamic	C_{Tdyn}	Nm/rad	For calculating torsional vibration
Excitation frequency	f_{err}	Hz	Excitation frequency of motor or driven machine
Moment of inertia	J	kgm ²	Moment of inertia of coupling sides 1 and 2
Axial misalignment	ΔK_a	mm	Axial misalignment of the coupling halves
Radial misalignment	ΔK_r	mm	Radial misalignment of the coupling halves
Angular misalignment	ΔK_w	°	Angular misalignment of the coupling halves
Service factor	FB		Factor expressing the real coupling load as a ratio of the nominal coupling load
Frequency factor	FF		Factor expressing the frequency dependence of the fatigue torque load
Temperature factor	FT		Factor taking into account the reduction in strength of flexible rubber materials at a higher temperature
Weight	m	kg	Weight of the coupling
Rated speed	n_N	rpm	Coupling speed
Maximum coupling speed	n_{Kmax}	rpm	Maximum permissible coupling speed
Rated power	P_N	kW	Rated output on the coupling, usually the output of the driven machine
Rated torque	T_N	Nm	Rated torque as nominal load on the coupling
Fatigue torque	T_W	Nm	Amplitude of the dynamic coupling load
Maximum torque	T_{max}	Nm	More frequently occurring maximum load, e.g. during starting
Overload torque	T_{OL}	Nm	Very infrequently occurring maximum load, e.g. during short circuit or blocking conditions
Rated coupling torque	T_{KN}	Nm	Torque which can be transmitted as static torque by the coupling over the period of use.
Maximum coupling torque	T_{Kmax}	Nm	Torque which can be frequently transmitted (up to 25 times an hour) as maximum torque by the coupling.
Coupling overload torque	T_{KOL}	Nm	Torque which can very infrequently be transmitted as maximum torque by the coupling.
Fatigue coupling torque	T_{KW}	Nm	Torque amplitude which can be transmitted by the coupling as dynamic torque at a frequency of 10 Hz over the period of use.
Resonance factor	V_R		Factor specifying the torque increase at resonance
Temperature	T_a	°C	Ambient temperature of the coupling in operation
Damping coefficient	Ψ	psi	Damping parameter

SELECTION OF THE COUPLING SERIES

E

The coupling series is frequently determined by the driven machine and the design of the drive train. Common selection criteria are listed below and assigned to coupling properties, which are used to select the coupling series. Additionally, the price of the coupling and availability are important criteria for determining the coupling series to be used.

The **FLUDEX series** operates positively and transmits the torque with the aid of a flowing oil or water filling.

FLUDEX couplings are used to reduce starting and/or overload torques. During starting, the motor may, for example, run up within a very short time; because of the FLUDEX coupling, the drive train with the driven machine may accelerate after a delay and without increased torque load.

The FLUDEX coupling cannot compensate for shaft misalignment and is therefore designed in combination with a displacement coupling, a cardan shaft or a belt drive. The displacement coupling may be selected in accordance with the criteria described below.

Selection criteria	Torque range Rated coupling torque T_{KN}	Speed range Peripheral speed $v_{max} = DA \cdot n_{max}/19100$	Torsional stiffness		Highly flexible	Operating temperature range
			torsionally rigid	torsionally flexible		
ZAPEX	850 ... 7200000 Nm	60 m/s	■	-	-	-20 ... +80 °C
N-ARPEX	350 ... 2000000 Nm	110 m/s	■	-	-	-50 ... +280 °C
ARPEX	92 ... 2000000 Nm	100 m/s	■	-	-	-40 ... +280 °C
N-EUPEX	19 ... 62000 Nm	36 m/s	-	■	-	-50 ... +100 °C
N-EUPEX DS	19 ... 21200 Nm	36 m/s	-	■	-	-30 ... +80 °C
RUPEX	200 ... 1300000 Nm	60 m/s	-	■	-	-50 ... +100 °C
N-BIPEX	12 ... 4650 Nm	45 m/s	-	■	-	-50 ... +100 °C
ELPEX-B	24 ... 14500 Nm	35 m/s	-	-	■	-50 ... +70 °C
ELPEX-S	330 ... 63000 Nm	66 m/s	-	-	■	-40 ... +120 °C
ELPEX	1600 ... 900000 Nm	60 m/s	-	-	■	-40 ... +80 °C

Typical coupling solutions for different example applications

The specified application factors are recommendations; regulations, rules and practical experience take priority as assessment criteria.

No application factor need be taken into account with FLUDEX couplings.

In the case of highly flexible couplings of the ELPEX, ELPEX-S and ELPEX-B series, deviating application factors are stated in the product descriptions. FLUDEX couplings are mostly mounted on the high-speed gear shaft.

Example applications	Application factor FB
Electric motor without gear unit	
Centrifugal pumps	1.0
Piston pumps	1.5
Vacuum pumps	1.5
Fans with T_N less than 75 Nm	1.5
Fans with T_N from 75 to 750 Nm	1.75
Fans with T_N larger than 750 Nm	1.75
Blowers	1.5
Frequency converters / generators	1.25
Reciprocating compressors	1.75
Screw-type compressors	1.5
Internal-combustion engine without gear unit	
Generators	1.75
Pumps	1.5
Fans	1.75
Hydraulic pumps, excavators, construction machines	1.5
Compressors / screw-type compressors	1.5
Agricultural machinery	1.75
Other	
Turbine gear units	1.5
Hydraulic motor - gear unit	1.25
Electric motor with gear unit	
Chemical industry	
Extruders	1.5
Pumps - centrifugal pumps	1.0
Pumps - piston pumps	1.75
Pumps - plunger pumps	1.5
Reciprocating compressors	1.75
Calenders	1.5
Kneaders	1.75
Cooling drums	1.25
Mixers	1.25
Stirrers	1.25
Toasters	1.25
Drying drums	1.25
Centrifuges	1.25
Crushers	1.5
Power generation and conversion	
Compressed air, reciprocating compressors	1.75

Example applications	Application factor FB
Compressed air, screw-type compressors	1.25
Air - Blowers	1.5
Air - Cooling tower fans	1.5
Air - Turbine blowers	1.5
Generators, converters	1.25
Welding generators	1.25
Metal production, iron and steel works	
Plate tilters	1.5
Ingot pushers	1.75
Slabbing mill	1.75
Coiling machines	1.5
Roller straightening machines	1.5
Roller tables	1.75
Shears	1.75
Rollers	1.75
Metal working machines	
Plate bending machines	1.5
Plate straightening machines	1.5
Hammers	1.75
Planing machines	1.75
Presses, forging presses	1.75
Shears	1.5
Grinding machines	1.25
Punches	1.5
Machine tools: Main drives	1.5
Machine tools: Auxiliary drives	1.25
Food industry	
Filling machines	1.25
Kneading machines	1.5
Mashers	1.5
Sugar cane production	1.5
Production machines	
Construction machines, hydraulic pumps	1.25
Construction machines, traversing gears	1.5
Construction machines, suction pumps	1.5
Construction machines, concrete mixers	1.5
Printing machines	1.25
Woodworking - barking drums	1.5
Woodworking - planing machines	1.5

Example applications	Application factor FB
Woodworking - reciprocating saws	1.5
Grinding machines	1.5
Textile machines - winders	1.5
Textile machines - printing machines	1.5
Textile machines - tanning vats	1.5
Textile machines - shredders	1.5
Textile machines - looms	1.5
Packaging machines	1.5
Brick molding machines	1.75
Transport and logistics	
Passenger transport - elevators	1.5
Passenger transport - escalators	1.5
Conveyor systems - bucket elevators	1.5
Conveyor systems - hauling winches	1.5
Conveyor systems - belt conveyors	1.5
Conveyor systems - endless-chain conveyors	1.5
Conveyor systems - circular conveyors	1.5
Conveyor systems - screw conveyors	1.5
Conveyor systems - inclined hoists	1.5
Crane traversing gear	1.5
Hoisting gear	1.5
Crane lifting gear	2.0
Crane traveling gear	1.5
Crane slewing gear	1.5
Crane fly jib hoists	1.5
Cable railways	1.5
Drag lifts	1.5
Winches	1.5
Cellulose and paper	
Paper-making machines, all	1.5
Pulper drives	1.5
Cement industry	
Crushers	1.75
Rotary furnaces	1.5
Hammer mills	1.75
Ball mills	1.75
Pug mills	1.75
Mixers	1.5
Pipe mills	1.5
Beater mills	1.75
Separators	1.5
Roller presses	1.75

SELECTION OF THE COUPLING SIZE

E

The torque load of the coupling must be determined from the output of the driven machine and the coupling speed.

Rated coupling load $T_N = 9550 \times P_N / n_N$
 (T_N in Nm; P_N in kW; n_N in rpm)

The rated coupling load obtained in this way must be multiplied by factors and compared with the rated coupling torque. An ideal but expensive method is to measure the torque characteristic on the coupling. For this, Flender offers special adapters fitted with torque measuring devices.

The rated coupling torque T_{KN} is the torque which can be transmitted by the coupling over an appropriate period of use if the load is applied to the coupling purely statically at room temperature.

Application factors are to express the deviation of the real coupling load from the "ideal" load condition.

Coupling load in continuous operation

The operating principles of the driving and driven machines are divided into categories and the application factor FB derived from these in accordance with DIN 3990-1.

Application factor for N-EUPEX, N-EUPEX-DS, RUPEX, N-BIPEX, ELPEX-B, N-ARPEX, ARPEX, ZAPEX and FLUDEX

Torque characteristic of the driving machine	Torque characteristic of the driven machine			
	uniform	uniform with moderate shock loads	non uniform	very rough
uniform	1.0	1.25	1.5	1.75
uniform with moderate shock loads	1.25	1.5	1.75	2.0
non uniform	1.5	1.75	2.0	2.5

Examples of torque characteristic of driving machines:

- uniform: Electric motors with soft starting, steam turbines
- uniform with moderate shock loads: Electric motors without soft starting, hydraulic motors, gas and water turbines
- non uniform: Internal-combustion engines

Examples of torque characteristic in driven machines:

- uniform: Generators, centrifugal pumps for light fluids
- uniform with moderate shock loads: Centrifugal pumps for viscous fluids, elevators, machine tool drives, centrifuges, extruders, blowers, crane drives
- non uniform: Excavators, kneaders, conveyor systems, presses, mills
- very rough: Crushers, excavators, shredders, iron/smelting machinery

Temperature factor FT												
Coupling	Elastomer material	Low temperature °C	Temperature T_a on the coupling									
			under -30 °C	-30 °C up to 50 °C	up to 60 °C	up to 70 °C	up to 80 °C	up to 90 °C	up to 100 °C	up to 110 °C	up to 120 °C	
N-EUPEX	NBR	-30	-	1.0	1.0	1.0	1.0	1.0	-	-	-	-
N-EUPEX	NR	-50	1.1 ¹⁾	1.0	-	-	-	-	-	-	-	-
N-EUPEX	HNBR	-10	-	1.0	1.0	1.0	1.0	1.0	1.25	1.25	-	-
N-EUPEX DS	NBR	-30	-	1.0	1.0	1.0	1.0	1.0	-	-	-	-
RUPEX	NBR	-30	-	1.0	1.0	1.0	1.0	1.0	-	-	-	-
RUPEX	NR	-50	1.1	1.0	-	-	-	-	-	-	-	-
RUPEX	HNBR	-10	-	1.0	1.0	1.0	1.0	1.0	1.25	1.25	-	-
N-BIPEX	TPU	-50	1.0	1.0	1.0	1.0	1.0	1.0	1.0	1.0	-	-
ELPEX	NR	-40	1.1	1.0	1.25	1.40	1.60	-	-	-	-	-
ELPEX-B	NR	-50	1.1	1.0	-	-	-	-	-	-	-	-
ELPEX-B	CR	-15	-	1.0	1.0	1.0	-	-	-	-	-	-
ELPEX-S SN, NN, WN	NR	-40	1.1	1.0	1.25	1.40	1.60	-	-	-	-	-
ELPEX-S NX	VMQ	-40	1.1	1.0	1.0	1.0	1.0	1.1	1.25	1.4	1.6	-

- NR = natural rubber, natural-synthetic rubber mixture
- NBR = nitril-butadiene-rubber (Perbunan)
- HNBR = hydrated acrylonitrile butadiene rubber
- CR = chloroprene rubber (FRAS fire-resistant and anti-static)
- VMQ = silicone
- TPU = polyurethane

¹⁾ The N-EUPEX coupling is not suitable for shock loads when used at low temperatures.

Coupling size $T_{KN} \geq T_N \cdot FB \cdot FT$

In the case of ARPEX and ZAPEX coupling types, no temperature factor (FT = 1.0) need be taken into account.

Coupling load at maximum and overload conditions

The maximum torque is the highest load acting on the coupling in normal operation. Maximum torques at a frequency of up to 25 times an hour are permitted and must be lower than the maximum coupling torque. Examples of maximum torque conditions are: Starting operations, stopping operations or usual operating conditions with maximum load.

$T_{Kmax} \geq T_{Max} \cdot FT$

Overload torques are maximum loads which occur only in combination with special, infrequent operating conditions. Examples of overload torque conditions are: Motor short circuit, emergency stop or blocking because of component breakage. Overload torques at a frequency of once a month are permitted and must be lower than the maximum overload torque of the coupling. The overload condition may last only a short while, i.e. fractions of a second.

$T_{KOL} \geq T_{OL} \cdot FT$

Coupling load due to dynamic torque load

Applying the frequency factor FF, the dynamic torque load must be lower than the coupling fatigue torque.

Dynamic torque load

$T_{KW} \geq T_W \cdot FF$

Frequency of the dynamic torque load $f_{err} \leq 10$ Hz frequency factor FF = 1.0

Frequency of the dynamic torque load $f_{err} > 10$ Hz frequency factor FF = $\sqrt{(f_{err}/10 \text{ Hz})}$

For the ZAPEX and ARPEX series, the frequency factor is always FF = 1.0.

SELECTION OF THE COUPLING SIZE

E

Checking the maximum speed

For all load situations $n_{K_{max}} \geq n_{max}$

Checking permitted shaft misalignment

For all load situations, the actual shaft misalignment must be less than the permitted shaft misalignment.

Checking bore diameter, mounting geometry and coupling design

The check must be made on the basis of the dimension tables. The maximum bore diameter applies to parallel keyways to DIN 6885. For other keyway geometries, the maximum bore diameter can be reduced.

On request, couplings with adapted geometry can be provided.

Coupling behavior under overload conditions

The ZAPEX, N-ARPEX, ARPEX, N-EUPEX, RUPEX and N-BIPEX coupling series can withstand overloads until the breakage of metal parts. These coupling series are designated as fail-safe.

The N-EUPEX DS, ELPEX-B, ELPEX-S and ELPEX coupling series throw overload. The elastomer element of these couplings is irreparably damaged without damage to metal parts when subjected to excessive overload.

These coupling series are designated as non-fail-safe. These types that fail can be fitted with a so-called fail-safe device. This additional component enables emergency operation, even after the rubber element of the coupling has been irreparably damaged.

Checking shaft-hub connection

The torques specified in the tables of power ratings data of the coupling series do not necessarily apply to the shaft-hub connection. Depending on the shaft-hub connection, proof of form stability is required. Flender recommends obtaining proof of form strength by using calculation methods in accordance with the current state of the art.

Fitting recommendations for the shaft-hub connection are given in the **Appendix**.

The coupling hub is frequently fitted flush with the shaft end face. If the shaft projects, the risk of collision with other coupling parts must be checked. If the shaft is set back, in addition to the load-bearing capacity of the shaft-hub connection, the correct positioning of the hub must be ensured as well. If the bearing hub length is insufficient, restorative forces may cause tilting movements and so wear to and impairment of the axial retention. Also, the position of the set screw to be positioned on sufficient shaft or parallel key material must be noted.

Shaft-hub connection	Suggestion for calculation method
Keyway connection to DIN 6885-1	DIN 6892
Shrink fit	DIN 7190
Spline to DIN 5480	
Bolted flange connection	VDI 2230
Flange connection with close-fitting bolts	

Checking low temperature and chemically aggressive environment

The minimum permitted coupling temperature is specified in the Temperature factor FT table. In the case of chemically aggressive environments, please consult the manufacturer.

FEATURES OF THE STANDARD TYPE



Couplings	Features of the standard type
All coupling series except ARPEX clamping hubs and FLUDEX with keyway to ASME B17.1	Bore tolerance H7
N-ARPEX and ARPEX clamping hubs	Bore tolerance H6
FLUDEX couplings with keyway to ASME B17.1	Hollow shafts: bore tolerance K7 other parts: Bore tolerance M7
All coupling series with bore diameter - imperial	Parallel keyway to ASME B17.1
Bore diameter metric in the case of ZAPEX, N-ARPEX and ARPEX coupling series as well as coupling hubs with applied brake disks or brake drums of the N-EUPEX and RUPEX series	Parallel keyway to DIN 6885-1 keyway width P9
Bore diameter metric in the case of the N-EUPEX, RUPEX, N-BIPEX, ELPEX-S, ELPEX-B, ELPEX, FLUDEX coupling series	Parallel keyway to DIN 6885-1 keyway width JS9
All coupling series except FLUDEX	Axial locking by means of set screw
FLUDEX coupling series	Axial lock by means of set screw or end washer
All coupling series	Balancing in accordance with half parallel key standard
ZAPEX, N-ARPEX, ARPEX, N-EUPEX, RUPEX, N-BIPEX, ELPEX-S, ELPEX-B and ELPEX coupling series	Balancing quality G16
FLUDEX coupling series	Balancing quality G6.3
All series	Unpainted
All series	Preservation with cleaning emulsion
FLUDEX couplings	Fuse 140 °C

Configurator

The article number can be obtained with the help of the Configurator. The coupling can be selected in a product configurator and specified using selection menus.

The coupling can be selected via "Technical selection" (technical selection) or via "Direct selection" (via article-no.).

The Configurator is available under flender.com.

FLUID COUPLINGS FLUDEX SERIES



General	13/2
Benefits	13/2
Application	13/3
Design and configurations	13/3
Function	13/7
Technical specifications	13/9
Configuration	13/11
Mass moments of inertia	13/17
Technical data for type selection	13/19

FLUDEX coupling as an aid for starting the IEC motors	13/20
Speed $n = 1500$ rpm	13/20
Speed $n = 3000$ rpm	13/24
Type FA0	13/28
Type FAR	13/30
Type FAD	13/32
Type FAE	13/33
Type FAM	13/34
Type FADB	13/35
Type FADS SB	13/36
Type FADS HB	13/37
Oil filling quantities for FA series	13/38
Type FGO	13/40
Type FGD	13/41
Type FGE	13/42
Type FGM	13/43
Oil filling quantities for FG series	13/44
Type FVO	13/46
Type FVD	13/47
Type FVE	13/48
Type FVM	13/49
Oil filling quantities for FV series	13/50
Type FNO	13/52
Type FNA	13/53
Type FND	13/54
Type FNDB	13/56
Type FNDS SB	13/58
Type FNDS HB	13/60
Oil filling quantities for FN series	13/62
Spare and wear parts	13/64



FLUDEX
FLENDER

GENERAL

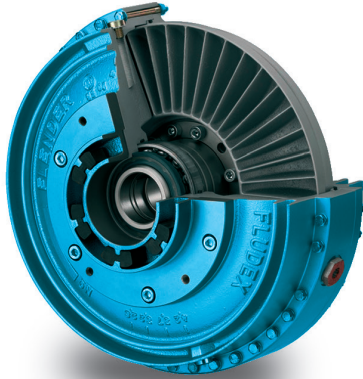

Coupling suitable for use in potentially explosive atmospheres.

Complies with the current ATEX Directive for:

CE  II 2G Ex h IIB T3 Gb X

 II 2D Ex h IIIC T160°C Db X

 I M2 Ex h Mb X

FLUDEX couplings marked with Ex are constructed with fusible safety plugs 110 °C.

Benefits

FLUDEX couplings are hydrodynamic fluid couplings which operate on the Föttinger principle. The coupling parts on the input and output sides are not mechanically connected to each other. Output is transmitted via the oil filling which rotates in the coupling and is conducted over radially arranged blades.

FLUDEX couplings limit starting and maximum torque in the drive train and, through the property of rotational slip, serve as an aid to starting the motor, as overload protection in the event of fault and for isolating torsional vibration.

When large masses are started up, the drive train is accelerated only at the torque determined by the coupling characteristic. The starting operation is spread over time, the driven machine started softly and smoothly.

In the case of special operating conditions, such as overload or blocking of the driven machine, the FLUDEX coupling limits the maximum torque load and prevents the inert effect of the rotating motor mass on the drive train. The coupling then acts as a load-holding safety clutch until the drive is shut off by the motor control or coupling monitoring system.

The FLUDEX coupling further acts as a means of decoupling during torsional vibration excitation. Torsional vibration excitation with a frequency of > 5 Hz is virtually absorbed by the coupling.

To compensate for shaft misalignment, the FLUDEX coupling is combined with a displacement coupling e.g. of the N-EUPEX type.

All FLUDEX couplings are designed with radial unset blades and are therefore suitable for rotation in both directions and reversing operation. They can be fitted horizontally, at an angle or vertically. In the case of FLUDEX couplings with a delay chamber it must be ensured, when fitting at an angle or vertically, that the delay chamber is below the working chamber.

Application

FLUDEX couplings are used in drives for conveyor systems such as belt conveyors, bucket elevators and chain conveyors. In heavy industry FLUDEX couplings are used for applications such as blade wheel drives, crushers, roller presses, mixers, large ventilators, boiler feed pumps, large compressors, centrifuges and auxiliary drives for mills.

Further applications are, for example, pump drives, PTO generator drives, wind power systems and door and gate drives.

In drives with diesel engines, FLUDEX couplings are used on driven machines with a high mass moment of inertia.

Design and configurations

FLUDEX couplings are constructed of just a few, robust components. Internal components include the hollow shaft or solid shaft (106), to which the blade wheel (105) is connected. The outer housing comprises the cover (102) and the blade wheel housing (101). The joint is constructed as a bolted flange joint and sealed with an O ring. The outer housing and the shaft or hollow shaft have double bearing support and are sealed off to the outside with radial shaft seals. The coupling is provided with two filler plugs (153) with integral overflow protection and with one or two fusible safety plugs (103) in the coupling housing for protection against overheating. The fusible safety plug or a screw plug fitted in the same position also serves as a fluid drain plug and with the aid of a scale marking on the housing can be used as a level indicator.

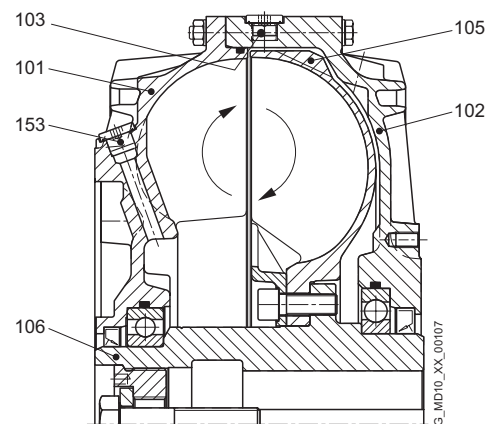

Materials

- Blade wheel and housing:
Cast aluminum AlSi10Mg or AlSi9Mg
- Shaft and hollow shaft:
Steel with a yield point higher than 400 N/mm²
- Static seals and radial shaft seals:
Perbunan NBR or Viton FPM
- Add-on parts:
Grey cast iron EN-GJL-250, spheroidal graphite cast iron EN-GJS-400 or steel

Fusible safety plugs

If a FLUDEX coupling is operated with an impermissibly high slip for a prolonged period, the oil filling and the coupling housing will overheat. Fusible safety plugs which release the oil filling into the environment upon reaching a preset temperature are therefore fitted in each coupling housing. These protect the coupling from irreparable damage through overheating or overpressure and disconnect the drive motor from the driven machine.

GENERAL

Thermal equipment

Equipment	Suitability for coupling continuous operating temperatures	Fusible safety plug	Sealing materials
Standard	up to 85 °C	110 °C	NBR FPM
	up to 85 °C	140 °C	NBR FPM
	up to 110 °C	160 °C	FPM
ATEX	up to 85 °C	110 °C ex	NBR FPM
With thermal switch ¹⁾	up to 85 °C	140 °C + thermal switch 110 °C	NBR FPM
	up to 110 °C	160 °C + thermal switch 140 °C	FPM
With transmitter ¹⁾	up to 85 °C	160 °C + EOC transmitter (125 °C)	NBR
	up to 110 °C		FPM

Thermal switching equipment

By adding thermal switching equipment leakage and loss of the hydraulic fluid as well as a risk to and contamination of the environment in the event that the coupling overheats can be avoided.

The thermal switching equipment does not work if a machine side is blocked and the coupling housing is connected to this side. If the coupling is stationary, the switching pin cannot actuate the switching equipment.

The thermal switching equipment comprises the thermal switch and the switchgear.

The switchgear comprises a limit switch with a make-and-break contact and a swiveling cam. Limit switch and cam are mounted on a common base plate. The thermal switch is screwed into the housing in place of a screw plug. The fusible safety plug (with a higher response temperature) remains in the coupling for additional safety.

If the set temperature is exceeded, the switching pin is released from the fusible element, emerges 10 mm from the housing and actuates the switchgear while the coupling is rotating. The switchgear can cut out the drive motor and/or trigger an optical or acoustic alarm signal. The housing of the coupling remains closed and no operating fluid will escape.

Continuous operating temperature	Thermal switch	Fusible safety plug
< 85 °C	110 °C	140 °C
> 85 ° ... 110 °C	140 °C	160 °C

¹⁾ Not available for size 222.

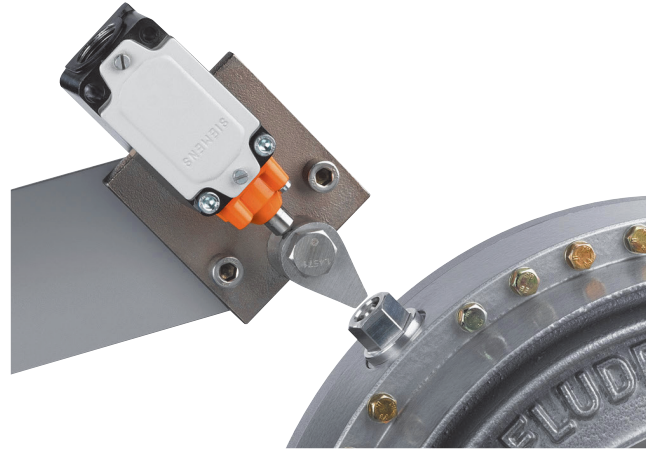
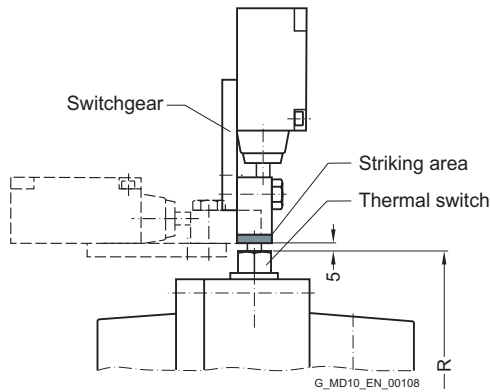

	Coupling size												
	297	342	370	395	425	450	490	516	565	590	655	755	887
Perm. speed in rpm	2500	2240	2100	2000	1900	1800	1650	1600	1500	1450	1250	1100	1000
Radius of travel R in mm	188	215	226	239	251	271	292	307	330	346	383	435	507

From coupling size 297, the thermal switching equipment can be used up to a peripheral speed of 50 m/s. At higher speeds, an EOC system should be provided.

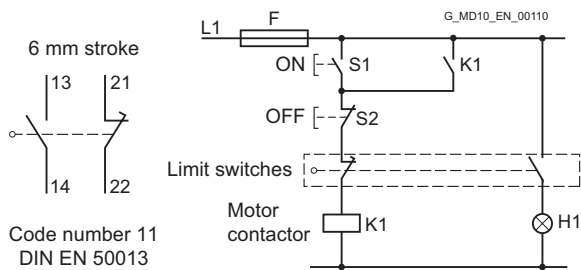

Snap-action switching contact

Wiring proposition

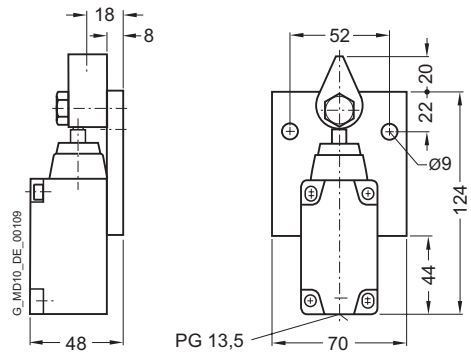

Switchgear: FFA:000000652020

GENERAL

EOC system

On the EOC system the temperature-dependent magnitude of the magnetic field of the EOC transmitter is measured and used for a switching pulse. The transmitter signal is transmitted via the fixed sensor to the evaluation instrument and there compared with the set value. If the signal does not exceed the minimum value or no signal is received, the relay of the evaluation instrument switches over. This can cause a malfunction message to be sent and the motor cut out. The coupling housing remains closed.

The fusible safety plug with a higher response temperature remains in the coupling for additional safety. The response temperature of the EOC system is 125 °C.

Components of the EOC system

Component	Article No.
EOC transmitter with seal	FFA:000001194899
EOC sensor	FFA:000000361460
Evaluation instrument EWD	FFA:000001205294

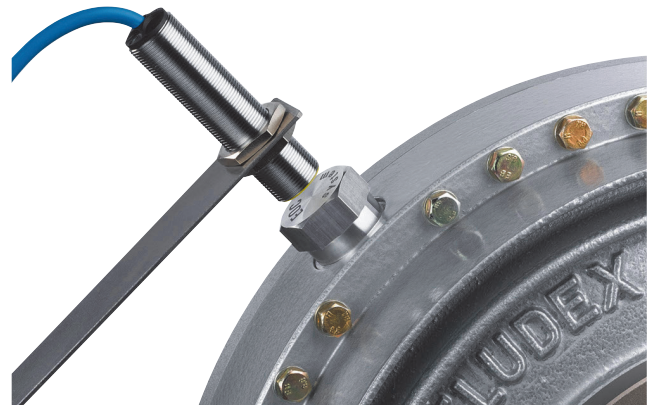
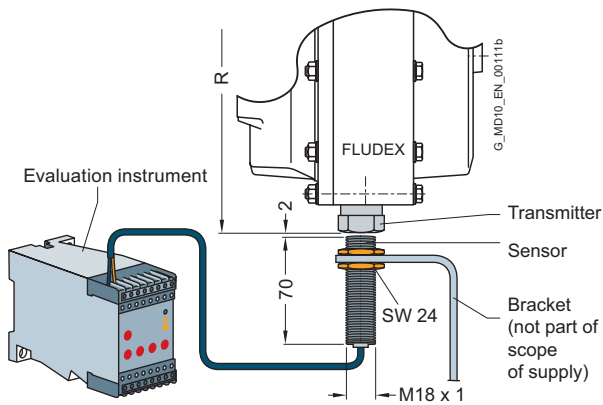

13

Coupling size	Radius of travel R to the transmitter in mm												
	297	342	370	395	425	450	490	516	565	590	655	755	887
Radius of travel R to the transmitter in mm	188	215	226	239	251	271	292	307	330	346	383	435	507

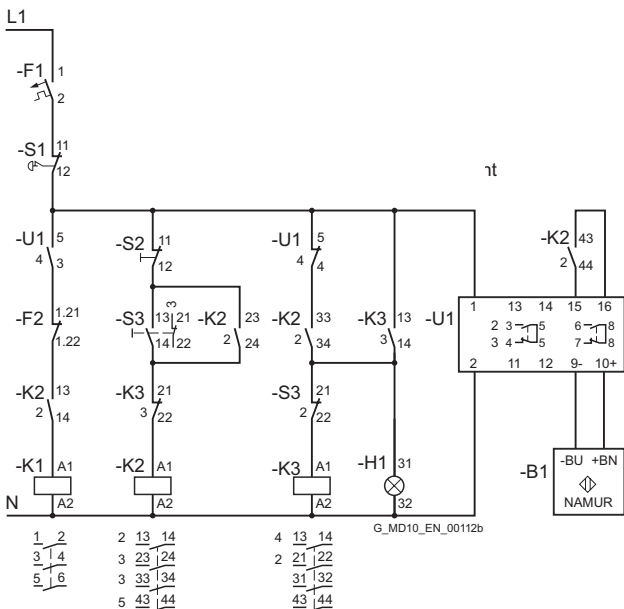

Wiring proposition

- B1 Sensor
- F1 Fuse
- F2 Motor protection switch
- H1 Malfunction
- K1 Motor protection
- K2 Contactor relay
- K3 Contactor relay
- S1 Emergency stop
- S2 Motor Off
- S3 Motor On
- U1 Evaluation instrument

Function

Föttinger principle

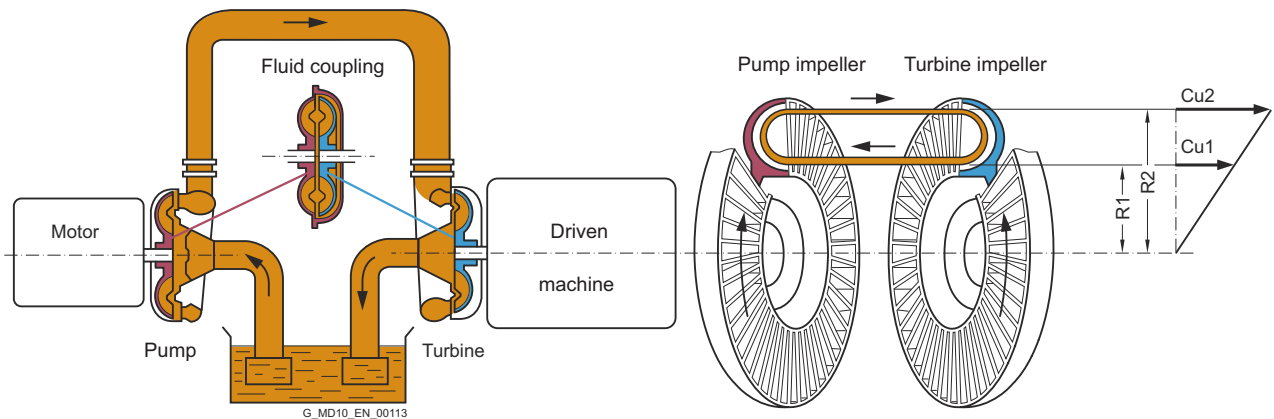

Two opposing, radially bladed impellers are housed in a leakproof housing. The impellers are not mechanically connected to each other. Because of the axially parallel arranged blades, the torque is transmitted independently of the direction of rotation and solely by the oil filling.

Hydrodynamic couplings have the characteristic properties of fluid flow engines. The transmissible torque depends on the density and quantity of the operating fluid and increases as the square of the drive speed and the fifth power of the profile diameter denoting the coupling size. In the driven pump impeller, mechanical energy is converted into kinetic flow energy of the operating fluid. In the turbine impeller, which is connected to the output side, flow energy is converted back to mechanical energy.

To generate the operating fluid circulation necessary for torque transmission, a difference in speed is necessary between the pump and turbine impellers. A centrifugal force pressure field is set up that is greater in the faster rotating pump impeller than in the turbine impeller. The difference in speed, usually termed "slip", at the continuous operating point of the coupling is between 2 % and 6 %, depending on application and coupling size. Immediately after drive motor start-up slip is 100 %, i.e. the pump impeller is driven at the speed of the motor, but the turbine impeller remains stationary.

Slip multiplied by the transmitted power represents the power loss of the coupling, which is converted into heat inside the oil filling. The amount of heat generated must be released into the environment via the coupling housing to prevent an impermissible temperature rise. The rated coupling output is mainly determined by the power loss which can be dissipated at a still acceptable operating temperature or a reasonable set slip limit. This distinguishes the FLUDEX coupling from all positively acting coupling assembly options for which the rated coupling torque is the defining characteristic.

Depending on the FLUDEX coupling series, drive is via the inner rotor (shaft/hollow shaft with rigidly connected blade wheel) or via the bladed housing impeller (blade wheel housing). The driving impeller is the pump impeller, and the driven impeller is the turbine impeller.

A low-viscosity mineral oil VG 22/VG 32, which also serves to lubricate the bearings, is used as fluid. In special types water, a water emulsion or low-flammability fluid may be used as a non-combustible fluid.

GENERAL

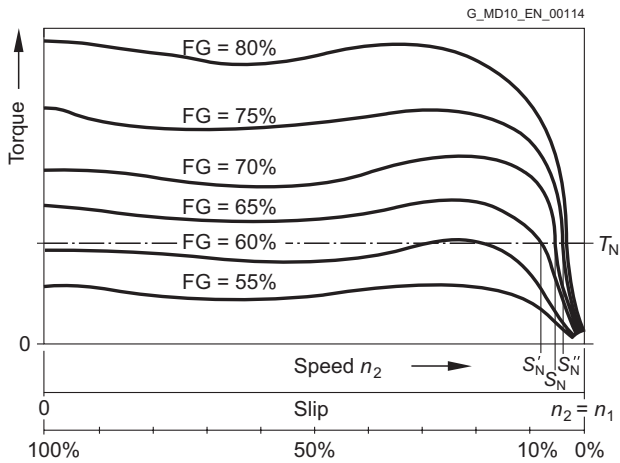

Slip-torque characteristics for different filling levels FG

The torque characteristic depends on the oil filling quantity FG in the coupling. This enables the transmissible torque on starting up to be set via the filling level. With a higher filling level the starting torque increases, while the operating slip and thus the coupling temperature rise decreases.

Conversely, with a lower filling level the starting torque decreases, the coupling becomes softer, while slip and coupling temperature rise.

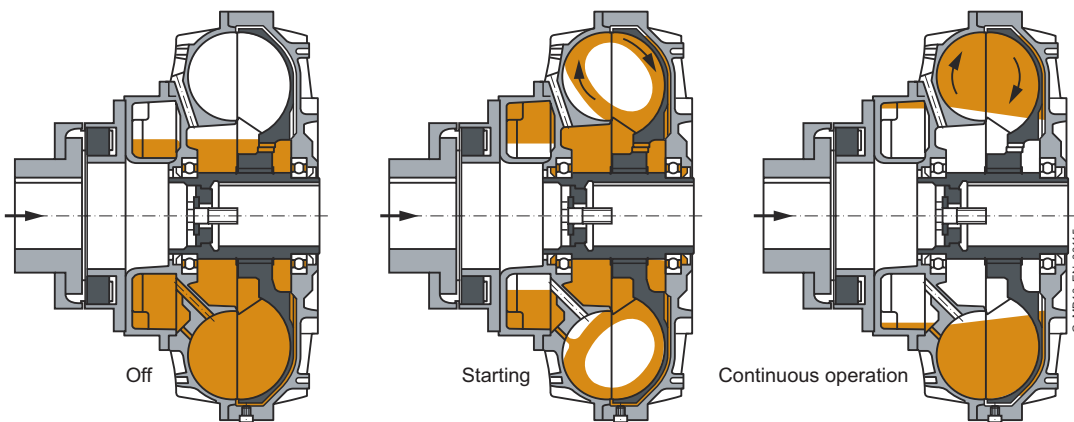

Operation of the delay chamber

Starting torque can be reduced without increasing continuous operating slip by using a type of coupling with a delay chamber. On these couplings part of the oil filling is initially stored inactively in the delay chamber. The starting torque is considerably reduced because of the thus reduced starting filling in the working chamber of the coupling. The filling in the delay chamber runs very slowly,

mostly only at the finish of the starting operation, from the delay chamber into the working chamber, causing the active filling in it to rise gradually and the continuous operating slip to reach a value corresponding to the whole filling.

Technical specifications

Balancing FLUDEX couplings

In deviation from the balancing specifications in **Chapter E**, all FLUDEX couplings complying with DIN ISO 21940 are balanced to balancing quality G6.3 for 1800 rpm. For operating speeds higher than 1800 rpm micro-balancing, based on operating speed, can be requested.

Balancing is a two-level balancing with the specified oil quantity or a 75 % filling.

FLUDEX couplings are balanced in accordance with the half parallel key standard. Other balancing standards must be specified in the order.

Add-on couplings are subject to the standards as set out in **Chapter E**.

Oil filling

FLUDEX couplings can be delivered with or without oil filling.

- Delivery without oil filling
- Delivery with oil filling
- Delivery without oil filling but with oil filling quantity specification in liters

Hollow shafts of the FA, FG and FV series

Variant of FLUDEX hollow shafts only with finished bore.

Operating temperature range of FLUDEX couplings

FLUDEX couplings are suitable for ambient temperatures of between -40 °C and +40 °C.

For use at temperatures below -15 °C, FLUDEX couplings are exclusively delivered with NBR seals (Perbunan).

For use at temperatures below -20 °C, FLUDEX couplings are generally delivered without oil filling.

To select the operating oil for low temperatures, ensure that the pour point of the oil is sufficiently low and that it is compatible with the sealing elements.

The temperature limits of the N-EUPEX add-on coupling are shown in part 7 of this catalogue.

If other displacement couplings are combined with a FLUDEX coupling, their respective temperature limits must be taken into account.

GENERAL

Operating conditions for FLUDEX couplings in potentially explosive atmospheres

The coupling with fusible safety plugs with identity marking Ⓢ T3 is suitable for the operating conditions set out in the ATEX Directive 2014/34/EU:

Equipment group II (above-ground applications)

Temperature class T3 of categories 2 and 3 for environments where there are potentially explosive gas, vapors, mist and air mixtures and for environments where dust can form potentially explosive atmospheres.

Equipment group I (below-ground applications) of category M2

Ⓢ If used in potentially explosive environments under ground, aluminum couplings must be provided with a robust enclosure to preclude the risk of ignition caused by e.g. friction, impact or friction sparks. The deposit of heavy-metal oxides (rust) on the coupling housing must be prevented by the enclosure or other suitable means.

Ⓢ FLUDEX couplings can be delivered with fitted brake disk or V-belt pulley. Designing the belt drive or the brake disk to conform with the guidelines is the responsibility of the sub-assembly supplier. It should be noted that there is a risk from, amongst other things, electrostatic charges and hot surfaces. Under BGR 132 (regulations of German Institute for Occupational Safety) the use of V-belts in conjunction with IIC gases is not permitted.

Axial retention

Axial retention is provided by a set screw or end washer with a retaining screw for shaft ends to DIN 748/1 long with a centering thread to DIN 332/2.

Bore and keyway width tolerances are specified in Chapter A.

Weights specified in the dimension order tables apply to maximum bore diameters without oil filling.

Configuration

Selection of FLUDEX coupling

In accordance with the requirements catalog various series, sizes and types of FLUDEX coupling are available. The FLUDEX coupling series is characterized by various flow chamber configurations, fitted delay chambers or fittings in the flow chamber. The types are determined by the design of the add-on coupling.

This results in different starting factors and characteristics which can be used for the most varied applications. The size is specified by stating the flow outside diameter.

When selecting, the series required for the application, taking into account the starting factor and the characteristic, must be selected.

Selection of FLUDEX series

Series	Description
FA../FG..	Basic coupling without delay chamber
FV..	Coupling with delay chamber
FN..	Coupling with large delay chamber

FLUDEX couplings, which are to be used solely as an aid to starting the motor under no special conditions, can be selected according to the assignment tables from **Page 13/20** (for $n = 1500 \text{ min}^{-1}$) or from **Page 13/24** (for $n = 3000 \text{ min}^{-1}$).

If special requirements, based on the operating method of the prime mover or driven machine, are made of the coupling or the coupling is to be used in extreme environmental conditions, please give specific details in the enquiry or order. The form "Technical specifications for the selection of type and size" on **Page 13/19** can be used for this purpose.

Start-up characteristics during the starting process

Depending on the series selected, different starting characteristics arise during starting.

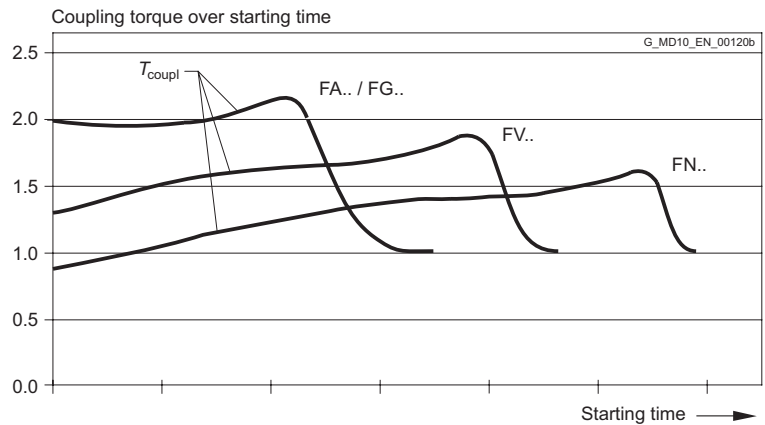
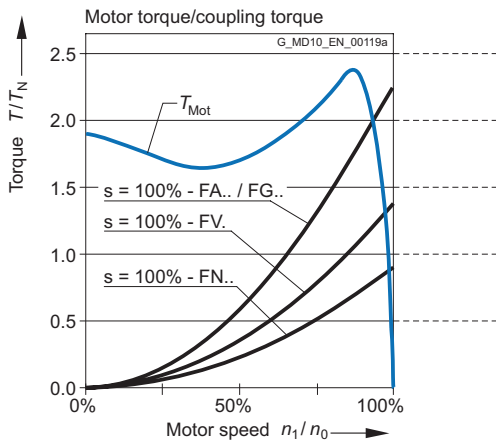

GENERAL

FA series – drive via the hollow shaft (impeller drive)

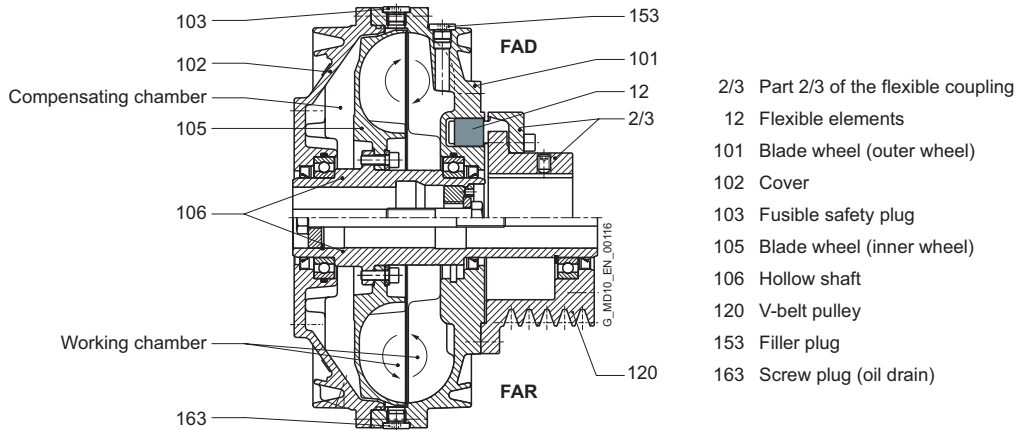

FLUDEX FA series couplings are basic couplings (without delay chamber) which are driven via the hollow shaft (106) with attached blade wheel (105). This enables the advantages of the compensating chamber and the working chamber to be used to best effect. Combinations with brake drums/disks and pulleys can also be easily achieved. When the coupling is started, part of the oil filling in the area of greatest slip is forced into the radially inner chambers and the compensating chamber by the strong rotational flow. This causes the effective oil filling in the working

chamber to be reduced and the desired torque limitation (approx. twice TN) to be achieved during starting. By means of additional fittings the coupling torque at the start of the starting operation can be limited to approx. 1.5 times the rated value. During run-up to speed the compensating chamber again empties into the working chamber, and this helps to reduce slip.

FG and FV series – drive via the housing

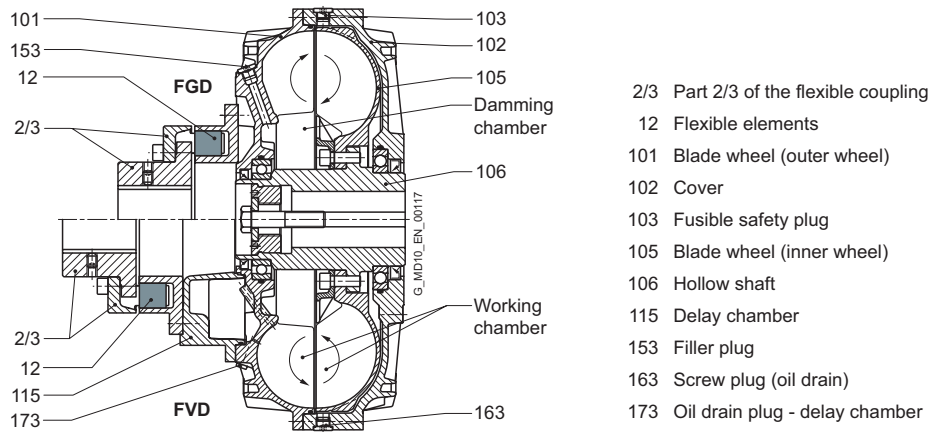

FLUDEX FG and FV series couplings are designed for drive via the coupling housing. In the FV series (coupling with delay chamber), the motor drives the coupling housing, comprising a blade wheel (101) and a cover (102), via the flexible N-EUPEX coupling (part 2/3) and the delay chamber (115). The rotational flow of the coupling filling drives the blade wheel (105) and the hollow shaft (106) on the output side, which is mounted on the gear unit or driven machine shaft. In the FG series (basic coupling), there is no delay chamber, and the flexible coupling is directly flange-mounted on the blade wheel.

When the coupling is started up, part of the oil filling is forced into the damming chamber. This enables the desired torque limitation (approx. twice T_N) to be achieved during motor starting. In the FV series the delay chamber also receives part of the oil filling in accordance with the fluid level when the coupling is stationary. During starting the effective oil filling in the working chamber is reduced by the amount of fluid in the delay chamber, thus considerably reducing the starting torque (approx. 1.5 times T_N).

From the delay chamber located on the drive side, the oil is fed back time-dependently to the working chamber via small holes and the coupling torque is raised, even if the output is blocked.

This replenishing function enables a drive to be soft-started with a very low starting torque and with an almost load-free motor. At the same time, however, increased load torques can be overcome by the torque increase in the coupling.

The property of the coupling with delay chamber can be used advantageously, for example, to soft-start empty, partly loaded and fully loaded conveyor belts.

FG series couplings are used for normal starting torque limitation, as a starting clutch for isolating vibration and for overload limitation in the event of drive blockage.

GENERAL

FN series – drive via the housing

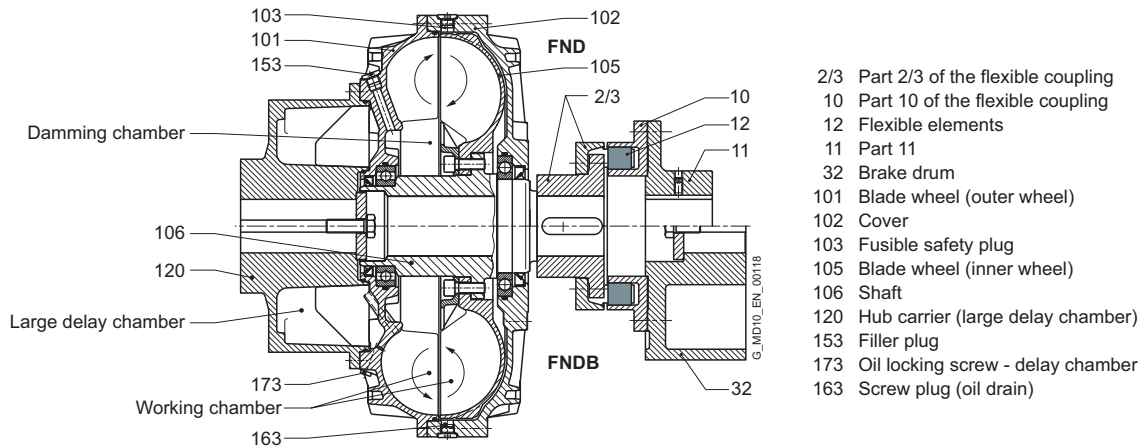

FLUDEX FN series couplings have a larger delay chamber than the FV series. The delay chamber is designed as a hub carrier (120) and is mounted on the motor shaft. The hub carrier is flange-fitted to the housing (101, 102) of the FLUDEX coupling. Output is via the blade wheel (105) and the shaft (106) to the flexible N-EUPEX coupling connecting to the gear unit or driven machine. With types FND, FNDB and FNDS the coupling can be dismantled radially without moving the coupled machines.

The normally stronger motor shaft bears the weight of the hub carrier (cast version) and the main coupling. The gear unit shaft carries only the brake drum or disk and the output-side part of the flexible coupling. At the same time, the principle of the drive-side delay chamber with the capacity for increasing torque time-dependently is retained. FN couplings have the same fields of application as FV couplings. However, they offer special advantages in the brake disk design because of the weight distribution.

Because of the larger delay chamber, FN couplings enable even softer starting than FV couplings. Torque limitation during motor starting is approx. 1.3 times T_N . A further advantage of types FNDB and FNDS is the favorable weight distribution.

Selection of FLUDEX type

Listed in the catalog are FLUDEX couplings with pulley, brake drum, brake disk and flexible N-EUPEX coupling.

Further types, e.g. in combination with a torsionally rigid steel membrane coupling of the ARPEX series or a highly flexible coupling of the ELPEX or ELPEX-S series, are available.

Series	Description	Type	Add-on coupling	Characteristic feature
FA	<ul style="list-style-type: none"> without delay chamber impeller-driven Starting torque: $T_{max} = 2.0 \cdot T_{eff}$ Starting aid for standard motors and torsional vibration isolation 	FAO	Without	<ul style="list-style-type: none"> Basic coupling with connecting flange
		FAR	Without	<ul style="list-style-type: none"> with attached pulley
		FAD	N-EUPEX D	<ul style="list-style-type: none"> enables change of flexible elements without axial displacement of the machine
		FAE	N-EUPEX E	<ul style="list-style-type: none"> enables larger bores on the output side
		FAM	N-EUPEX M	<ul style="list-style-type: none"> enables a short fitting length
		FADB	N-EUPEX D	<ul style="list-style-type: none"> with brake drum
		FADS SB	N-EUPEX D	<ul style="list-style-type: none"> with brake disk for stopping brakes enables change of flexible elements without axial displacement of the machine
		FADS HB	N-EUPEX D	<ul style="list-style-type: none"> with brake disk for blocking brakes enables change of flexible elements without axial displacement of the machine
FG	<ul style="list-style-type: none"> without delay chamber Housing-driven Starting torque: $T_{max} = 2.0 \cdot T_{eff}$ Starting aid for standard motors, for torsional vibration isolation and for overload limitation in the event of drive blockage. 	FGO	Without	<ul style="list-style-type: none"> Basic coupling with connecting flange
		FGD	N-EUPEX D	<ul style="list-style-type: none"> enables change of flexible elements without axial displacement of the machine
		FGE	N-EUPEX E	<ul style="list-style-type: none"> enables larger bores on the output side
		FGM	N-EUPEX M	<ul style="list-style-type: none"> enables a short fitting length
FV	<ul style="list-style-type: none"> with delay chamber Housing-driven Starting torque: $T_{max} = 1.5 \cdot T_{eff}$ Starting aid for motors and soft-starting of conveyor equipment 	FVO	Without	<ul style="list-style-type: none"> Coupling with connecting flange
		FVD	N-EUPEX D	<ul style="list-style-type: none"> enables change of flexible elements without axial displacement of the machine
		FVE	N-EUPEX E	<ul style="list-style-type: none"> enables larger bores on the output side
		FVM	N-EUPEX M	<ul style="list-style-type: none"> enables a short fitting length
FN	<ul style="list-style-type: none"> with large delay chamber Housing drive via hub carrier Starting torque: $T_{max} = 1.3 \cdot T_{eff}$ Starting aid for motors with very unfavorable characteristic and soft-starting of empty and full conveying equipment favorable weight distribution on brake-drum variant 	FNO	Without	<ul style="list-style-type: none"> Coupling with connecting shaft
		FNA	N-EUPEX A	<ul style="list-style-type: none"> enables a short fitting length enables change of flexible elements without axial displacement of the machine
		FND	N-EUPEX D	<ul style="list-style-type: none"> enables change of flexible elements without axial displacement of the machine enables fitting and dismantling of the coupling without displacement of the coupled machine
		FNDB	N-EUPEX D	<ul style="list-style-type: none"> with brake drum enables change of flexible elements without axial displacement of the machine enables fitting and dismantling of the coupling without displacement of the coupled machine
		FNDS SB	N-EUPEX D	<ul style="list-style-type: none"> with brake disk for stopping brakes enables change of flexible elements without axial displacement of the machine enables fitting and dismantling of the coupling without displacement of the coupled machine
		FNDS HB	N-EUPEX D	<ul style="list-style-type: none"> with brake disk for blocking brakes enables change of flexible elements without axial displacement of the machine enables fitting and dismantling of the coupling without displacement of the coupled machine

The maximum shaft misalignments permissible for an N-EUPEX add-on coupling are shown in **catalog FLE 10.2**. For greater shaft misalignments FLUDEX couplings can be combined with cardan shafts or other displacement couplings.

FLUDEX couplings designed specifically for operation with water/water emulsion are available for use in mining applications.

GENERAL

Selection of FLUDEX size

The FLUDEX size is determined by the output to be transmitted in comparison with the rated outputs listed in the following tables. No application factors or additional safety factors need be taken into consideration.

The rated outputs stated in the tables normally require the maximum permissible filling (80 % to 85 %) of the coupling and because of operating slip, lead to the coupling heating up by approx. 50 °C relative to the ambient (cooling air) temperature. With lower outputs, coupling heating will be proportionately lower.

If for continuous operation of the coupling an absolute temperature (ambient temperature + coupling heating) of >85 °C is expected, the coupling must be fitted with FPM seals and 160 °C fusible safety plugs.

When selecting the size of a FLUDEX coupling in ATEX design or for operation with water/water emulsion, please note that these versions are normally designed with fusible safety plugs 110 °C and the maximum permitted coupling temperature must be limited to 85 °C.

FA series														FLUDEX size
Speed in rpm														
600	740	890	980	1180	1350	1470	1600	1770	2000	2300	2600	2950	3550	
Rated output P_N in kW														
	1.2	1.6	2.8	4.2	5.5	6.9	8.7	11.7	15	19	24	33		222
1.2	2.3	4	5.5	9	14	18.5	23	29	37	48	60	70	90	297
2.6	4.8	8.7	11.5	18	27	34	40	51	65	82	97	120	145	342
5.7	10	16	21	36	49	61	74	87	105	135	165	180		395
11	21	32	41	65	90	110	127	155	190	230	290	370		450
19	36	60	75	115	154	190	215	260	310	395				516
37	69	109	134	200	260	320	360	435	540					590

FG, FV and FN series														FLUDEX size
Speed in rpm														
600	740	890	980	1180	1350	1470	1600	1770	2000	2300	2600	2950	3550	
Rated output P_N in kW														
4	7.5	12	16	26	38	48	61	85	110	140	170	220	290	370
7.5	15	23	30	48	70	90	115	140	175	220	280	340		425
15	30	45	58	95	140	180	210	245	300	380	480			490
28	55	85	110	180	255	300	350	420	525	660				565
55	110	170	220	350	450	520	600	730	900					655
110	210	330	440	600	760	870	1010	1220						755
240	440	700	810	1130	1440	1660								887
480	880	1400	1600	2000	2350	2500								887D¹⁾

¹⁾ D = Multi-pass version on request.

Mass moments of inertia

FA series										
FLUDEX size	Series		Types						Oil filling quantity	
	FA	FAO	FAD	FAE	FAM	FADB	FADS SB	FADS HB	max.	
	J_I	J_A	J_A	J_A	J_A	J_A	J_A	J_A	J_A	l
	kgm ²	kgm ²	kgm ²	kgm ²	kgm ²	kgm ²	kgm ²	kgm ²	kgm ²	
222	0.014	0.056	0.061	0.061	0.06	0.084	0.287	0.109		1.55
297	0.04	0.173	0.193	0.193	0.193	0.226	0.673	0.246		3.7
342	0.092	0.314	0.356	0.352	0.353	0.469	1.002	0.42		6.6
395	0.203	0.66	0.745	0.73	-	1.03	1.814	1.15		9.5
450	0.404	1.087	1.217	1.217	-	1.497	3.611	1.818		13.4
516	0.896	2.109	2.439	-	-	3.359	5.969	3.238		22.7
590	1.295	3.455	3.785	-	-	6.605	7.315	4.584		33

FAR series					
FLUDEX size	Series		Oil filling quantity		
	J_I	J_A			
	kgm ²	kgm ²	max. l		
222	0.014	2 · SPZ 100 0.062	3 · SPZ 160 0.071	1.55	
297	0.107	5 · SPZ 150 0.202	4 · SPA 190 0.235	5 · SPA 224 0.273	3.7
342	0.095	5 · SPA 180 0.386			6.6
395	5 · SPB = 0,214 7 · SPB = 0,210	5 · SPB 224 0.84	7 · SPB 236 0.96	7 · SPB 280 1.144	9.5
450	0.426	8 · SPB 250 1.467			13.4
516	0.946	10 · SPB 315 3.209			22.7
590	1.375	12 · SPC 315 4.955			33

FG/FV series												
FLUDEX size	Series		Types								Oil filling quantity	
	FG	FV	FGO	FVO	FGD	FVD	FGE	FVE	FGM	FVM	FG	FV
	J_I	J_I	J_A	J_A	J_A	J_A	J_A	J_A	J_A	J_A	max.	max.
	kgm ²	kgm ²	kgm ²	kgm ²	kgm ²	kgm ²	kgm ²	kgm ²	kgm ²	kgm ²	l	l
370	0.191	0.191	0.519	0.551	0.571	0.603	0.571	0.603	0.571	0.603	7.2	8
425	0.342	0.342	0.819	0.876	0.989	1.046	0.974	1.031	0.963	1.02	11	12
490	0.723	0.723	1.992	2.11	2.312	2.43	2.272	2.39	2.264	2.382	17	18.5
565	1.269	1.269	3.216	3.441	3.696	3.921	3.636	3.861	3.616	3.841	25.5	28
655	2.567	2.567	7.287	7.757	8.687	9.157	-	-	-	-	40	44
755	4.856	4.856	12.575	13.291	14.775	15.491	-	-	-	-	59	65
887	11.817	11.817	26.832	28.212	30.102	31.482	-	-	-	-	98	107

Note

- Mass moments of inertia J (including the power-transmitting oil filling components) apply to maximum bores

J_I Mass moment of inertia of the inner rotor (hollow shaft [106] + blade wheel [105]) in kgm²

J_A Mass moment of inertia of the outer housing (shell [101] + cover [102]) + any parts of the add-on coupling connected to them) in kgm²

GENERAL

FN series										
FLUDEX size	Hub carrier part	Series	Types					Weights		Oil filling quantity max. l
			FN J_A kgm ²	FNO J_I kgm ²	FNA J_I kgm ²	FND J_I kgm ²	FNDS SB J_I kgm ²	FNDS HB J_I kgm ²	Y mm	
370	Standard	0.657	0.237	0.281	0.32	1.18	0.386	197	685	8.2
	Long	0.647						227		
425	Standard	1.107	0.343	0.47	0.491	1.841	0.659	224	970	12.5
	Long	1.102						254		
490	Standard	2.48	0.737	0.954	0.999	3.009	1.285	235	1450	19
	Long	2.474						265		
565	Standard	4.175	1.364	1.715	1.835	5.075	2.081	278	2050	29
	Long	4.251						318		
655	Standard	9.319	2.567	3.587	3.777	6.777	4.701	330	3100	45
	Long	9.523						370		
755	Standard	15.616	4.91	6.878	7.198	12.078	9.689	352	4300	67
	Long	15.95						392		
887	Standard	33.662	11.832	15.132	16.632	24.03	20.428	406	7250	110
	Long	34.462						456		

Type FNDB							
FLUDEX size	Hub carrier part	Brake drum ØDBT · BBT	J_A kgm ²	J_I kgm ²	Weights		Oil filling quantity max. l
					Y mm	F_Y N	
370	Standard	Ø315 · 118	0.657	0.64	197	685	8.2
		Ø400 · 150		1.341			
370	Long	Ø315 · 118	0.647	0.64	227	970	12.5
		Ø400 · 150		1.341			
425	Standard	Ø315 · 118	1.107	0.811	224	970	12.5
		Ø400 · 150		1.492			
425	Long	Ø315 · 118	1.102	0.811	254	1450	19
		Ø400 · 150		1.492			
490	Standard	Ø400 · 150	2.48	1.994	235	1450	19
		Ø500 · 190		4.009			
490	Long	Ø400 · 150	2.474	1.994	265	2050	29
		Ø500 · 190		4.009			
565	Standard	Ø400 · 150	4.175	2.835	278	2050	29
		Ø500 · 190		4.775			
565	Long	Ø400 · 150	4.251	2.835	318	3100	45
		Ø500 · 190		4.775			
655	Standard	Ø500 · 190	9.319	6.677	330	3100	45
		Ø630 · 236		11.577			
655	Long	Ø500 · 190	9.523	6.677	370	4300	67
		Ø630 · 236		11.577			
755	Standard	Ø630 · 236	15.616	15.178	352	4300	67
			15.95		392		
887	Standard	Ø710 · 265	33.662	30.832	406	7250	110
			34.462		456		

Note

- Mass moments of inertia J (including the power-transmitting oil filling components) apply to maximum bores

J_I Mass moment of inertia of the inner rotor (shaft (106) + blade wheel (105)) + any parts of the add-on coupling connected to them in kgm²

J_A Mass moment of inertia of the outer housing (shell (101) + cover (102)) + hub carrier (120) in kgm²

Y Centroidal distance of the drive-side coupling masses, measured from the hub end face of the hub carrier.

F_Y Effective weight in mass center including maximum oil filling quantity

FLUDEX COUPLING AS AN AID FOR STARTING THE IEC MOTORS

Speed $n = 1500$ rpm, Type FAR with fitted V-belt pulley

This assignment offers safety in normal load cases and includes standard types with 140 °C fusible safety plugs, for horizontal fitting and an ambient air temperature from -40 °C to +40 °C.

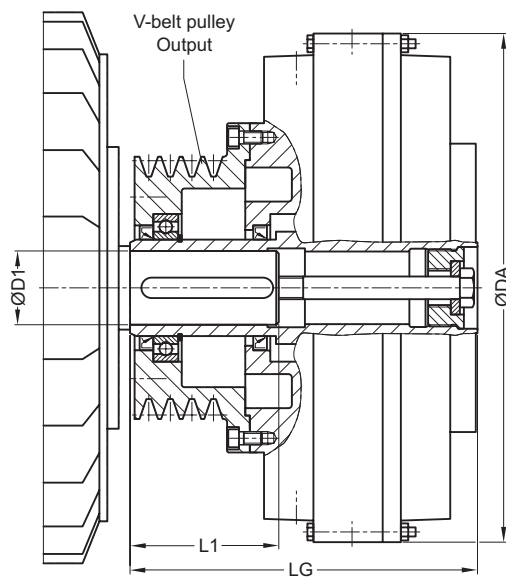

13

Three-phase motor Size	1500 min ⁻¹		FLUDEX coupling			V-belt pulley			Article no. ¹⁾	Weight		
	P_M kW	D1 · L1 mm	Size	Oil filling l	DA mm	LG mm	Profile, pitch Ø mm	Chamfer number			Recommended no. of belts	
80 M	0.55	19 · 40	222	0.9	263	153	SPZ 100	2	1	2LC0900-0AF90-0AA0	12	
	0.75	19 · 40		1			SPZ 100	2	1			
90 S	1.1	24 · 50		1.1			SPZ 100	2	1	2LC0900-0AF90-0AA0		
90 L	1.5	24 · 50		1.2			SPZ 100	2	1	2LC0900-0AF90-0AA0		
100 L	2.2	28 · 60		1.4			SPZ 100	2	2	2LC0900-0AF90-0AA0		
	3	28 · 60		1.5			SPZ 100	2	2			
112 M	4	28 · 60		1.55			SPZ 160	3	2	2LC0900-0AF91-0AA0		14
132 S	5.5	38 · 80		1.55			SPZ 160	3	2	2LC0900-0AF91-0AA0		

Configurable variants ¹⁾

- Delivery without oil filling
 Delivery with oil filling with specification of oil filling quantity in l
 Delivery without oil filling with oil filling quantity specification in l

¹⁾ To identify complete item numbers specifying the available finish boring options and – if necessary – further order options, please use our configurators on flender.com.

²⁾ Flank-open belts required.

↗ For online configuration on flender.com, click on the item no.

Three-phase motor			FLUDEX coupling				V-belt pulley			↗ Article no. ¹⁾	Weight <i>m</i> kg
Size	1500 min ⁻¹		Size	Oil filling	DA	LG	Profile, pitch Ø	Chamfer number	Recommended no. of belts		
	<i>P_M</i> kW	D1 · L1 mm		l	mm	mm	mm				
132 M	7.5	38 · 80	297	3.2	340	226	SPZ 150	5	3	2LC0900-1AF90-0AA0	
160 M	11	42 · 110		3.5			SPZ 150	5	4	2LC0900-1AF90-0AA0	
160 L	15	42 · 110		3.7			SPZ 150	5	5	2LC0900-1AF90-0AA0	
180 M	18.5	48 · 110	342	3.7	400	278	SPA 190	4	4	2LC0900-1AF91-0AA0	
180 L	22	48 · 110		5.5			SPA 180	5	5	2LC0900-2AF90-0AA0	
200 L	30	55 · 110		6			SPA 180	5	5 ²⁾	2LC0900-2AF90-0AA0	
225 S	37	60 · 140	395	7.6	448	325	SPB 224	5	5	2LC0900-3AF90-0AA0	
225 M	45	60 · 140		7.9			SPB 224	5	5	2LC0900-3AF90-0AA0	
250 M	55	65 · 140		8.4			SPB 224	5	5 ²⁾	2LC0900-3AF90-0AA0	
280 S	75	75 · 140	450	10.8	512	410	SPB 250	8	7	2LC0900-4AF90-0AA0	
280 M	90	75 · 140		11.3			SPB 250	8	8	2LC0900-4AF90-0AA0	
315 S	110	80 · 170		12			SPB 250	8	8 ²⁾	2LC0900-4AF90-0AA0	
315 M	132	80 · 170	516	17.7	584	491	SPB 315	10	10	2LC0900-5AF90-0AA0	
	160	80 · 170		18.6			SPB 315	10	10 ²⁾		

Configurable variants ¹⁾

- Delivery without oil filling
Delivery with oil filling with specification of oil filling quantity in l
Delivery without oil filling with oil filling quantity specification in l

Notes

- The specified coupling weights are effective for maximum bores without oil filling.
- Delivery with oil filling only above -20 °C
- Axial retention is provided by a set screw and/or end washer with a retaining screw for shaft ends to DIN 748/1 long with a centering thread to DIN 332/2.
- For mass moments of inertia, centroidal distance Y and weight FY, see Page 13/18.

Ordering example

- Drive with motor 200 L, 30 kW at 1470 rpm with starting clutch and pulley
- FLUDEX FAR 342 coupling, standard type
- Hollow shaft: Bore ØD1 = 55H7 with keyway to DIN 6885/1 and retaining screw, with pulley 5xSPA Ø180.

Article no. delivery without oil filling:
2LC0900-2AF90-0AA0-Z L1D

Article no. delivery with oil filling:
2LC0900-1AF90-0AA0-Z L1D+F16+Y90
Plain text to Y90: 6.0 l

Article no. delivery with specification of oil filling quantity:
2LC0900-1AF90-0AA0-Z L1D+Y90
Plain text to Y90: 6.0 l

¹⁾ To identify complete item numbers specifying the available finish boring options and – if necessary – further order options, please use our configurators on flender.com.

²⁾ Flank-open belts required.

↗ For online configuration on flender.com, click on the item no.

FLUDEX COUPLING AS AN AID FOR STARTING THE IEC MOTORS

Speed $n = 1500$ rpm, Type FAD with N-EUPEX D add-on coupling

This assignment offers safety in normal load cases and includes standard types with 140 °C fusible safety plugs, for horizontal fitting and an ambient air temperature from -40 °C to +40 °C.

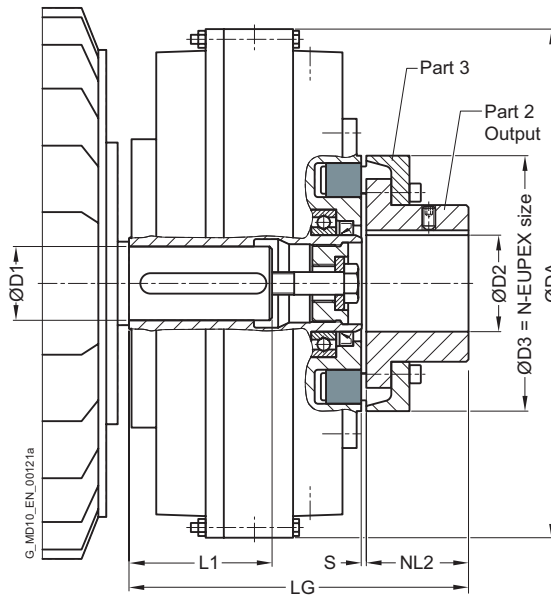

13

Three-phase motor Size	1500 min ⁻¹		FLUDEX coupling Size				N-EUPEX D add-on coupling			Article no. ¹⁾	Weight m kg
	P_M kW	D1 · L1 mm	Oil filling l	DA mm	LG mm	NL2 mm	D3 mm	D2 ²⁾ max. mm			
80 M	0.55	19 · 40	0.9	263	180	40	110	38	2LC0900-0AA9	12	
	0.75	19 · 40	1								
90 S	1.1	24 · 50	1.1								
90 L	1.5	24 · 50	1.2								
	2.2	28 · 60	1.4								
100 L	3	28 · 60	1.5								
	4	28 · 60	1.55								
112 M	5.5	38 · 80	1.55								
132 S									2LC0900-0AA9		

Configurable variants ¹⁾

- ØD2 Without finished bore
With finished bore
- Delivery without oil filling
Delivery with oil filling with specification of oil filling quantity in l
Delivery without oil filling with oil filling quantity specification in l

¹⁾ To identify complete item numbers specifying the available finish boring options and – if necessary – further order options, please use our configurators on flender.com.

²⁾ Larger bores on the power takeoff side are possible with the FAE type.

↗ For online configuration on flender.com, click on the item no.

Three-phase motor			FLUDEX coupling				N-EUPEX D add-on coupling			➤ Article no. ¹⁾	Weight <i>m</i> kg
Size	1500 min ⁻¹ <i>P_M</i> kW	D1 · L1 mm	Size	Oil filling l	DA mm	LG mm	NL2 mm	D3 mm	D2 ²⁾ max. mm		
132 M	7.5	38 · 80	297	3.2	340	233	50	125	45	2LC0900-1AA9	24
160 M	11	42 · 110		3.5						2LC0900-1AA9	
160 L	15	42 · 110		3.7						2LC0900-1AA9	
180 M	18.5	48 · 110		3.7						2LC0900-1AA9	
180 L	22	48 · 110	342	5.5	400	271	55	140	50	2LC0900-2AA9	34
200 L	30	55 · 110		6						2LC0900-2AA9	
225 S	37	60 · 140	395	7.6	448	299	90	225	85	2LC0900-3AA9	53
225 M	45	60 · 140		7.9						2LC0900-3AA9	
250 M	55	65 · 140	450	8.4	512	338	100	250	95	2LC0900-3AA9	70
280 S	75	75 · 140		10.8						2LC0900-4AA9	
280 M	90	75 · 140		11.3						2LC0900-4AA9	
315 S	110	80 · 170		12						2LC0900-4AA9	
315 M	132	80 · 170	516	17.7	584	398	125	315	120	2LC0900-5AA9	113
		160		80 · 170							

Configurable variants ¹⁾

- ØD2 Without finished bore
With finished bore
- Delivery without oil filling
Delivery with oil filling with specification of oil filling quantity in l
Delivery without oil filling with oil filling quantity specification in l

Notes

- The specified coupling weights are effective for maximum bores without oil filling.
- Delivery with oil filling only above -20 °C
- Axial retention is provided by a set screw and/or end washer with a retaining screw for shaft ends to DIN 748/1 long with a centering thread to DIN 332/2.
- For mass moments of inertia, centroidal distance Y and weight FY, see Page 13/18.

Ordering example

- Drive with motor 250 M, 55 kW at 1470 rpm with starting clutch for connecting two shafts.
- FLUDEX FAD 395 coupling, standard type
- Hollow shaft: Bore ØD1 = 65H7 with keyway to DIN 6885/1 and retaining screw
- Part 2: Bore ØD2 = 45H7 with keyway to DIN 6885/1 and set screw

Article no. delivery without oil filling:
2LC0900-3AA99-0AA0-Z L1F+M1A

Article no. delivery with oil filling:
2LC0900-3AA99-0AA0-Z L1F+M1A+F16+Y90
Plain text to Y90: 8.4 l

Article no. delivery with specification of oil filling quantity:
2LC0900-3AA99-0AA0-Z L1F+M1A+Y90
Plain text to Y90: 8.4 l

¹⁾ To identify complete item numbers specifying the available finish boring options and – if necessary – further order options, please use our configurators on flender.com.

²⁾ Larger bores on the power takeoff side are possible with the FAE type.

➤ For online configuration on flender.com, click on the item no.

FLUDEX COUPLING AS AN AID FOR STARTING THE IEC MOTORS

Speed $n = 3000$ rpm, Type FAR with fitted V-belt pulley

This assignment offers safety in normal load cases and includes standard types with 140 °C fusible safety plugs, for horizontal fitting and an ambient air temperature from -40 °C to +40 °C.

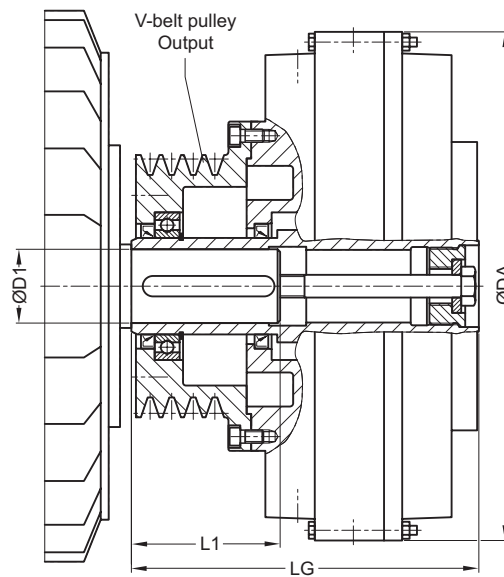

13

Three-phase motor			FLUDEX coupling				V-belt pulley			Article no. ¹⁾	Weight <i>m</i> kg	
Size	3000 min ⁻¹	D1 · L1	Oil filling	DA	LG	Profile, pitch Ø	Chamfer number	Recommended no. of belts				
	<i>P_M</i> kW	mm	l	mm	mm	mm						
90 S	1.5	24 · 50	0.7	263	153	SPZ 100	2	1	2LC0900-0AF90-0AA0	12		
90 L	2.2	24 · 50	0.8			SPZ 100	2	1				
100 L	3	28 · 60	0.9			SPZ 100	2	1				
112 M	4	28 · 60	1			SPZ 100	2	2				
132 S	5.5	38 · 80	1			SPZ 100	2	2			2LC0900-0AF90-0AA0	
	7.5	38 · 80	1.1			SPZ 160	3	2			2LC0900-0AF91-0AA0	
160 M	11	42 ³⁾ · 110	1.2			SPZ 160	3	2			2LC0900-0AF91-0AA0	
	15	42 ³⁾ · 110	1.3			SPZ 160	3	3				
160 L	18.5	42 ³⁾ · 110	1.4			SPZ 160	3	3			2LC0900-0AF91-0AA0	14

Configurable variants ¹⁾

- Delivery without oil filling
 Delivery with oil filling with specification of oil filling quantity in l
 Delivery without oil filling with oil filling quantity specification in l

¹⁾ To identify complete item numbers specifying the available finish boring options and – if necessary – further order options, please use our configurators on flender.com.

²⁾ Flank-open belts required.

³⁾ Version with flat groove as per DIN 6885/3.

➤ For online configuration on flender.com, click on the item no.

Three-phase motor			FLUDEX coupling				V-belt pulley			Article no. ¹⁾	Weight <i>m</i> kg
Size	3000 min ⁻¹		Size	Oil filling	DA	LG	Profile, pitch Ø	Chamfer number	Recommended no. of belts		
	<i>P_M</i> kW	D1 · L1 mm		l	mm	mm	mm				
180 M	22	48 · 110	297	2.5	340	226	SPZ 150	5	4	2LC0900-1AF90-0AA0	27
200 L	30	55 · 110		2.7			SPZ 150	5	5	2LC0900-1AF90-0AA0	
	37	55 · 110		2.8			SPA 190	4	4	2LC0900-1AF91-0AA0	32
225 M	45	55 · 110		2.9			SPA 224	5	4	2LC0900-1AF92-0AA0	35
250 M	55	60 ³⁾ · 140	3.1	SPA 224	5	5	2LC0900-1AF92-0AA0				
280 S	75	65 · 140	395	5.3	448	363.5	SPB 236	7	5	2LC0900-3AF91-0AA0	70
280 M	90	65 · 140		5.6			SPB 236	7	6	2LC0900-3AF91-0AA0	
315 S	110	65 · 140		5.9			SPB 236	7	7	2LC0900-3AF91-0AA0	
315 M	132	65 · 140		6.2			SPB 236	7	7 ²⁾	2LC0900-3AF91-0AA0	83
315 L	160	65 · 140		6.8			SPB 280	7	7 ²⁾	2LC0900-3AF92-0AA0	

Configurable variants ¹⁾

- Delivery without oil filling
Delivery with oil filling with specification of oil filling quantity in l
Delivery without oil filling with oil filling quantity specification in l

Notes

- The specified coupling weights are effective for maximum bores without oil filling.
- Delivery with oil filling only above -20 °C
- Axial retention is provided by a set screw and/or end washer with a retaining screw for shaft ends to DIN 748/1 long with a centering thread to DIN 332/2.
- For mass moments of inertia, centroidal distance Y and weight FY, see Page 13/18.

Ordering example

- Drive with motor 200 L, 37 kW at 2950 rpm with starting clutch and pulley
- FLUDEX FAR 297 coupling, standard type
- Hollow shaft: Bore ØD1 = 55H7 with keyway to DIN 6885/1 and retaining screw, with pulley 4xSPA Ø190.

Article no. delivery without oil filling:
2LC0900-1AF91-0AA0-Z L1D+W03+Y95

Article no. delivery with oil filling:
2LC0900-1AF91-0AA0-Z L1D+W03+F16+Y90
Plain text to Y90: 2,8 l

Article no. delivery with specification of oil filling quantity:
2LC0900-1AF91-0AA0-Z L1D+W03+F16+Y90
Plain text to Y90: 2,8 l

¹⁾ To identify complete item numbers specifying the available finish boring options and – if necessary – further order options, please use our configurators on flender.com.

²⁾ Flank-open belts required.

³⁾ Version with flat groove as per DIN 6885/3.

↗ For online configuration on flender.com, click on the item no.

FLUDEX COUPLING AS AN AID FOR STARTING THE IEC MOTORS

Speed $n = 3000$ rpm, Type FAD with N-EUPEX D add-on coupling

This assignment offers safety in normal load cases and includes standard types with 140 °C fusible safety plugs, for horizontal fitting and an ambient air temperature from -40 °C to +40 °C.

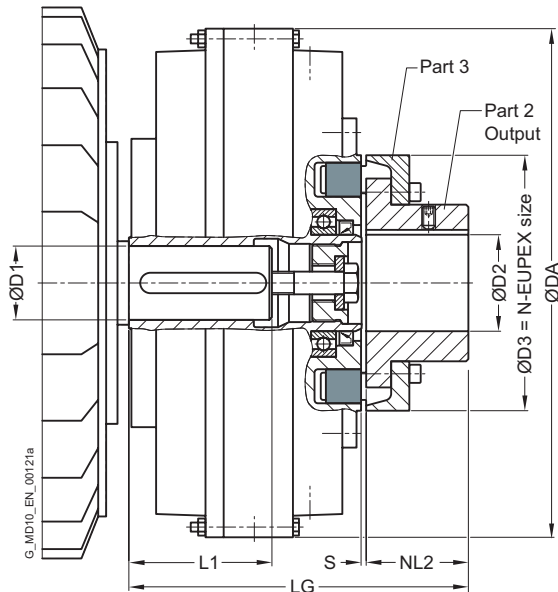

13

Three-phase motor Size	3000 min ⁻¹		FLUDEX coupling				N-EUPEX D add-on coupling			Article no. ¹⁾	Weight <i>m</i> kg
	P_M kW	D1 · L1 mm	Size	Oil filling l	DA mm	LG mm	NL2 mm	D3 mm	D2 ²⁾ max. mm		
90 S	1.5	24 · 50	222	0.7	263	180	40	110	38	2LC0900-0AA9	12
90 L	2.2	24 · 50		0.8							
100 L	3	28 · 60		0.9							
112 M	4	28 · 60		1							
132 S	5.5	38 · 80		1							
	7.5	38 · 80		1.1							
160 M	11	42 ³⁾ · 110		1.2							
	15	42 ³⁾ · 110		1.3							
160 L	18.5	42 ³⁾ · 110	1.4	2LC0900-0AA9							

Configurable variants ¹⁾

- ØD2 Without finished bore
With finished bore
- Delivery without oil filling
Delivery with oil filling with specification of oil filling quantity in l
Delivery without oil filling with oil filling quantity specification in l

¹⁾ To identify complete item numbers specifying the available finish boring options and – if necessary – further order options, please use our configurators on flender.com.

²⁾ Larger bores on the power takeoff side are possible with the FAE type.

³⁾ Version with flat groove as per DIN 6885/3.

↗ For online configuration on flender.com, click on the item no.

Three-phase motor			FLUDEX coupling				N-EUPEX D add-on coupling			Article no. ¹⁾	Weight <i>m</i> kg
Size	3000 min ⁻¹ <i>P_M</i> kW	D1 · L1 mm	Size	Oil filling l	DA mm	LG mm	NL2 mm	D3 mm	D2 ²⁾ max. mm		
180 M	22	48 · 110	297	2.5	340	233	50	125	45	2LC0900-1AA9	24
200 L	30	55 · 110		2.7						2LC0900-1AA9	
200 L	37	55 · 110		2.8						2LC0900-1AA9	
225 M	45	55 · 110		2.9						2LC0900-1AA9	
250 M	55	60 ³⁾ · 140		3.1						2LC0900-1AA9	
280 S	75	65 · 140	395	5.3	448	299	90	225	85	2LC0900-3AA9	53
280 M	90	65 · 140		5.6						2LC0900-3AA9	
315 S	110	65 · 140		5.9						2LC0900-3AA9	
315 M	132	65 · 140		6.2						2LC0900-3AA9	
315 L	160	65 · 140		6.8						2LC0900-3AA9	

Configurable variants¹⁾

- ØD2 Without finished bore
With finished bore
- Delivery without oil filling
Delivery with oil filling with specification of oil filling quantity in l
Delivery without oil filling with oil filling quantity specification in l

Notes

- The specified coupling weights are effective for maximum bores without oil filling.
- Delivery with oil filling only above -20 °C
- Axial retention is provided by a set screw and/or end washer with a retaining screw for shaft ends to DIN 748/1 long with a centering thread to DIN 332/2.
- For mass moments of inertia, centroidal distance Y and weight FY, see Page 13/18.

Ordering example

- Drive with motor 280 M, 90 kW at 2950 rpm with starting clutch for connecting two shafts.
- FLUDEX FAD 395 coupling, standard type
- Hollow shaft: Bore ØD1 = 65H7 with keyway to DIN 6885/1 and retaining screw
- Part 2: Bore ØD2 = 60H7 with keyway to DIN 6885/1 and set screw

Article no. delivery without oil filling:
2LC0900-3AA99-0AA0-Z L1F+M1E+W03

Article no. delivery with oil filling:
2LC0900-3AA99-0AA0-Z L1F+M1E+W03+F16+Y90
Plain text to Y90: 5.6 l

Article no. delivery with specification of oil filling quantity:
2LC0900-3AA99-0AA0-Z L1F+M1E+W03+Y90
Plain text to Y90: 5.6 l

¹⁾ To identify complete item numbers specifying the available finish boring options and – if necessary – further order options, please use our configurators on flender.com.

²⁾ Larger bores on the power takeoff side are possible with the FAE type.

³⁾ Version with flat groove as per DIN 6885/3.

↗ For online configuration on flender.com, click on the item no.

TYPE FAO

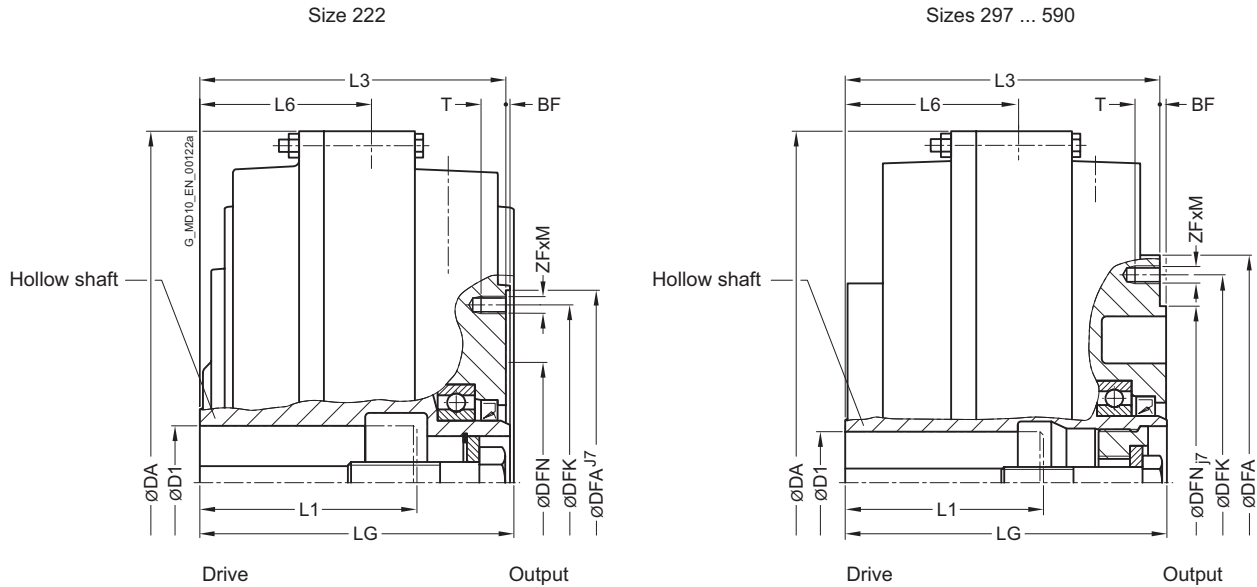

Size	Maximum speed n_{Kmax} rpm	FLUDEX coupling installation dimensions							Flange connection dimensions					Tightening torque for screws in thread ZF x M T_A Nm	Article no. ¹⁾	Weight m kg		
		D1 Keyway to DIN 6885		L1 max.	DA mm	L3 mm	L6 mm	LG mm	DFN mm	DFA mm	BF mm	DFK mm	ZF · M				T mm	
		min. mm	max. mm															Prefer- red bore mm
222	3600	>38 ²⁾	38 42 ²⁾	28	80	263	110	58	112	90	144	2	128	6 · M8	12	18.7	2LC0900-0AG90-0AA0	10
297	3600	>38 >55 ²⁾	38 55 60 ²⁾	28	80	340	145	83	150	125	195	3	172	6 · M8	12	18.7	2LC0900-1AG90-0AA0	18
342	3600	>55 ²⁾	55 60 ²⁾	48 + 55	110 120	400	174	101	180	140	230	4	205	8 · M10	15	31	2LC0900-2AG90-0AA0	26
395	3000		65	60 + 65	140	448	200.5	110.5	205	225	290	4	265	8 · M12	18	54	2LC0900-3AG90-0AA0	40

Configurable variants ¹⁾

- Delivery without oil filling
 Delivery with oil filling with specification of oil filling quantity in l
 Delivery without oil filling with oil filling quantity specification in l

¹⁾ To identify complete item numbers specifying the available finish boring options and – if necessary – further order options, please use our configurators on flender.com.

²⁾ Version with flat groove as per DIN 6885/3.

↗ For online configuration on flender.com, click on the item no.

Size	Maximum speed n_{Kmax} rpm	FLUDEX coupling installation dimensions								Flange connection dimensions						Tightening torque for screws in thread ZF x M T_A Nm	Article no. ¹⁾	Weight m kg
		D1 Keyway to DIN 6885			L1 max. mm	DA mm	L3 mm	L6 mm	LG mm	DFN mm	DFA mm	BF mm	DFK mm	ZF · M	T mm			
		min. mm	max. mm	Prefer- red bore mm														
450	3000		75	65 + 75	140	512	228	126	233	250	310	4	285	8 · M12	18	54	2LC0900-4AG90-0AA0	53
		>75	80	170														
516	2300		55		140	584	263	147	270	315	390	5	360	8 · M16	24	135	2LC0900-5AG90-0AA0	84
		>55	90	80	170													
590	2000		75		140	662	298	166	305	315	390	5	360	8 · M16	24	135	2LC0900-6AG90-0AA0	109
		>75	95	170														
		>95	100	210														

Configurable variants ¹⁾

- Delivery without oil filling
Delivery with oil filling with specification of oil filling quantity in l
Delivery without oil filling with oil filling quantity specification in l

Notes

- The specified coupling weights are effective for maximum bores without oil filling.
- Delivery with oil filling only above -20 °C
- For mass moments of inertia, centroidal distance Y and weight FY, see Page 13/18.

Ordering example

- Motor 37 kW, $P_{eff} = 30$ kW, $n_1 = 1470$ rpm, maximum output torque: $T_{max} = 2.0 \cdot T_{eff}$
- FLUDEX FAO coupling size 342
- Hollow shaft: Bore $\varnothing D1 = 60H7$ mm with keyway to DIN 6885/3 and retaining screw
- Seal set FPM
- Specification of oil filling quantity: 6.0 l (see Page 13/9)

Article no. with 160 °C fuse:

2LC0900-2AG90-0AA0-Z L1E+F08+Y90

Plain text to Y90: 6.0 l

¹⁾ To identify complete item numbers specifying the available finish boring options and – if necessary – further order options, please use our configurators on flender.com.

²⁾ Version with flat groove as per DIN 6885/3.

➤ For online configuration on flender.com, click on the item no.

TYPE FAR

with attached v-belt pulley

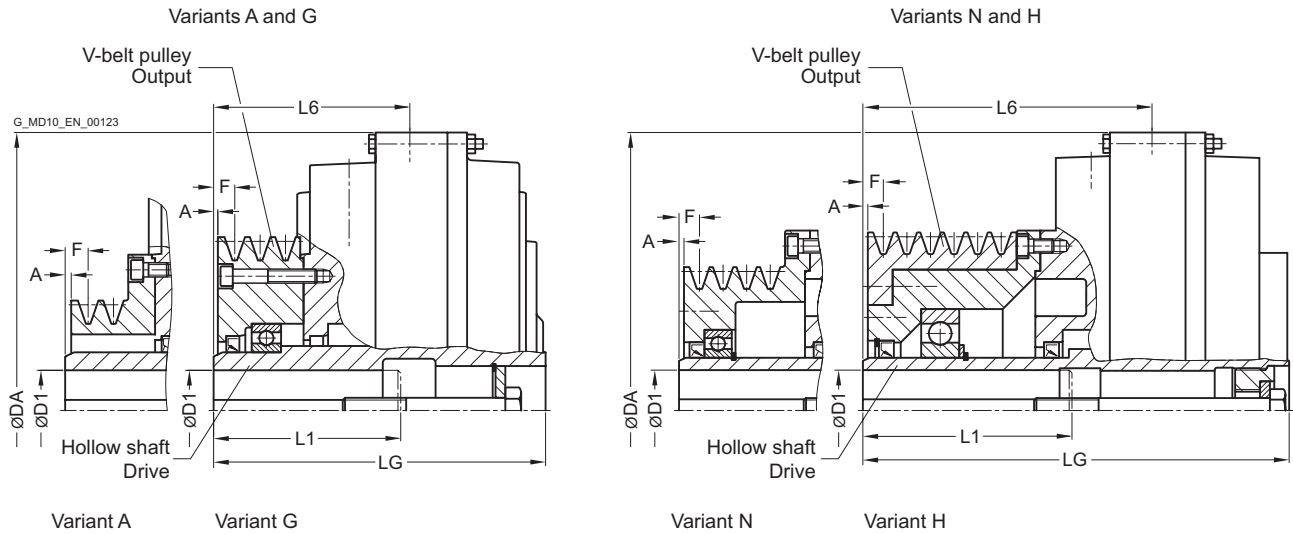

13

Size	Maximum speed n_{Kmax} rpm	FLUDEX coupling							V-belt pulley		Type	Article no. ¹⁾	Weight <i>m</i> kg			
		D1 Keyway to DIN 6885			L1 max. mm	DA mm	L6 mm	LG mm	Profile, pitch Ø mm	Chamfer number				A mm	F mm	
		min. mm	max. mm	Prefer- red bore mm												
222	3600	28	28	60	263	95	153	SPZ 100	2	1	9	A	2LC0900-0AF90-0AA0	12		
		>28	38	105				SPZ 160	3			G	2LC0900-0AF91-0AA0	14		
		>38 ²⁾	42 ²⁾	110												
297	3600	38		80	340	143	226	SPZ 150	5	2	10	N	2LC0900-1AF90-0AA0	27		
		>38	55	42				110	SPA 190			4	0	H	2LC0900-1AF91-0AA0	32
		>55 ²⁾	59 ²⁾					110	SPA 224			5	0	G	2LC0900-1AF92-0AA0	35
		>59 ²⁾	60 ²⁾					140	SPA 180			5	4	14	N	2LC0900-2AF90-0AA0
395	3000	55		110	448	214.5	325	SPB 224	5	4	16.5	N	2LC0900-3AF90-0AA0	63		
		>55	65	60 + 65				140	448			253	363.5	SPB 236	7	N
	2700	55		110	448	253	363.5	SPB 236	7			H	2LC0900-3AF92-0AA0	83		
		>55	75					140	SPB 280			7				

Configurable variants ¹⁾

- Delivery without oil filling
 Delivery with oil filling with specification of oil filling quantity in l
 Delivery without oil filling with oil filling quantity specification in l

¹⁾ To identify complete item numbers specifying the available finish boring options and – if necessary – further order options, please use our configurators on flender.com.

²⁾ Version with flat groove as per DIN 6885/3.

↗ For online configuration on flender.com, click on the item no.

Size	Maximum speed n_{Kmax} rpm	FLUDEX coupling							V-belt pulley				Article no. ¹⁾	Weight m kg	
		D1 Keyway to DIN 6885			L1 max. mm	DA mm	L6 mm	L6 mm	Profile, pitch Ø mm	Chamfer number	Type				
		min. mm	max. mm	Prefer- red bore mm							A mm	F mm			
450	3000		55		110	512	284	410	SPB 250	8	4	16.5	N	2LC0900-4AF90-0AA0	94
		>55	75	65 + 75	140										
		>75	80		170										
516	2300		55		110	584	344	491	SPB 315	10	4	16.5	N	2LC0900-5AF90-0AA0	152
		>55	75		140										
		>75	95		170										
590	2000		55		110	662	476	642	SPC 315	12	4	21	N	2LC0900-6AF90-0AA0	208
		>55	75		140										
		>75	95		170										
		>95	100		210										

Configurable variants¹⁾

- Delivery without oil filling
Delivery with oil filling with specification of oil filling quantity in l
Delivery without oil filling with oil filling quantity specification in l

Notes

- The specified coupling weights are effective for maximum bores without oil filling.
- Delivery with oil filling only above -20 °C

Ordering example

- Motor 45 kW, $P_{eff} = 37$ kW, $n_1 = 1470$ rpm, maximum output torque: $T_{max} = 2.0 \cdot T_{eff}$.
- FLUDEX FAR coupling size 395
- Hollow shaft: Bore $\varnothing D1 = 60H7$ mm with keyway to DIN 6885/1 and retaining screw
- Specification of oil filling quantity: 7.6 l (see Page 13/9)

Article no. with pulley 5xSPB224:
2LC0900-3AF90-0AA0-Z L1E+Y90
Plain text to Y90: 7.6 l

Article no. with pulley 7xSPB236:
2LC0900-3AF91-0AA0-Z L1E+Y90
Plain text to Y90: 7.6 l

Article no. with 160 °C fuse:
2LC0900-3AF90-0AA0-Z L1E+Y90+F08
Plain text to Y90: 7.6 l

¹⁾ To identify complete item numbers specifying the available finish boring options and – if necessary – further order options, please use our configurators on flender.com.

²⁾ Version with flat groove as per DIN 6885/3.

➤ For online configuration on flender.com, click on the item no.

TYPE FAD

with N-EUPEX D add-on coupling

Enables change of flexible elements without axial displacement of the shafts if the space "A" is provided.

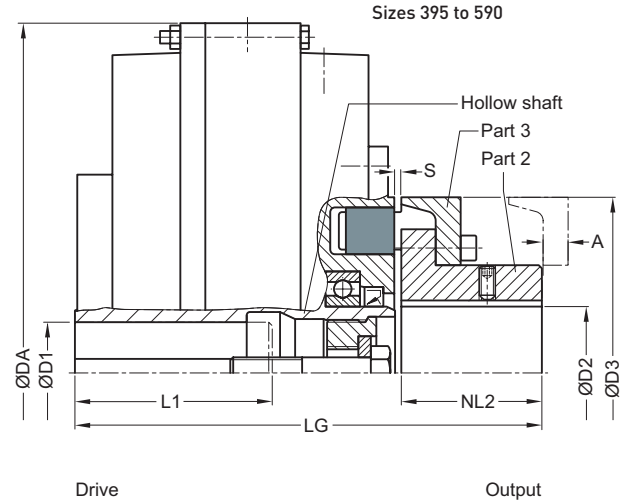
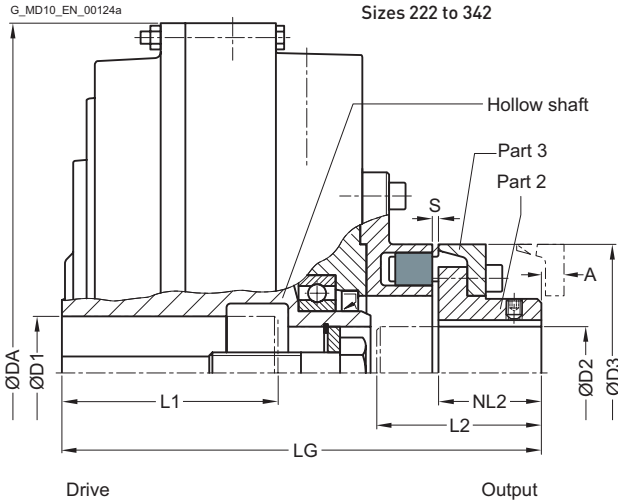

Size	Maximum speed n_{Kmax} rpm	FLUDEX coupling					N-EUPEX D add-on coupling						Article no. ¹⁾	Weight <i>m</i> kg	
		D1 Keyway to DIN 6885			L1 max. mm	DA mm	LG mm	D2 max. mm	L2 max. mm	NL2 mm	Size D3 mm	S mm			A mm
		min. mm	max. mm	Preferred bore mm											
222	3600	>38 ²⁾	38 42 ²⁾	28 80	80	263	180	38	65	40	110	3 ⁺¹ ₋₁	13	2LC0900-0AA9	12
297	3600	>38 >55 ²⁾	38 55 60 ²⁾	28 42 110	80 110	340	233	45	80	50	125	3 ⁺¹ ₋₁	11	2LC0900-1AA9	24
342	3600	>55 ²⁾	55 60 ²⁾	48 + 55 110	110 120	400	271	50	88	55	140	3 ⁺¹ ₋₁	16	2LC0900-2AA9	34
395	3000		65	60 + 65	140	448	299	85	90	90	225	4,5 ^{+1,5} _{-1,5}	9	2LC0900-3AA9	53
450	3000	>75	75 80	65 + 75 140	140 170	512	338	95	100	100	250	6 ⁺² ₋₃	11	2LC0900-4AA9	70
516	2300	>55	55 90	140 80	140 170	584	398	120	125	125	315	5 ⁺³ ₋₂	0	2LC0900-5AA9	113
590	2000	>75 >95	75 95 100	140 170 210	140 170 210	662	433	120	125	125	315	5 ⁺³ ₋₂	0	2LC0900-6AA9	138

Configurable variants ¹⁾

- ØD2 Without finished bore
With finished bore
- Delivery without oil filling
Delivery with oil filling with specification of oil filling quantity in l
Delivery without oil filling with oil filling quantity specification in l

Notes

- The specified coupling weights are effective for maximum bores without oil filling.
- Delivery with oil filling only above -20 °C

Ordering example

- Motor 160 kW, $P_{eff} = 132$ kW, $n_1 = 1470$ rpm, maximum output torque: $T_{max} = 2.0 \cdot T_{eff}$.
- FLUDEX FAD coupling size 516
- Hollow shaft: Bore ØD1= 80H7 mm with keyway to DIN 6885/1 and retaining screw
- Part 2: with finished bore ØD2 = 80H7
- Specification of oil filling quantity: 17.7 l [see Page 13/9]

Article no.: 2LC0900-5AA99-0AA0-Z L1J+M1J+Y90
Plain text to Y90: 17.7 l

¹⁾ To identify complete item numbers specifying the available finish boring options and – if necessary – further order options, please use our configurators on flender.com.

²⁾ Version with flat groove as per DIN 6885/3.

↗ For online configuration on flender.com, click on the item no.

TYPE FAE

with N-EUPEX E add-on coupling

Enables larger bores on the output side.

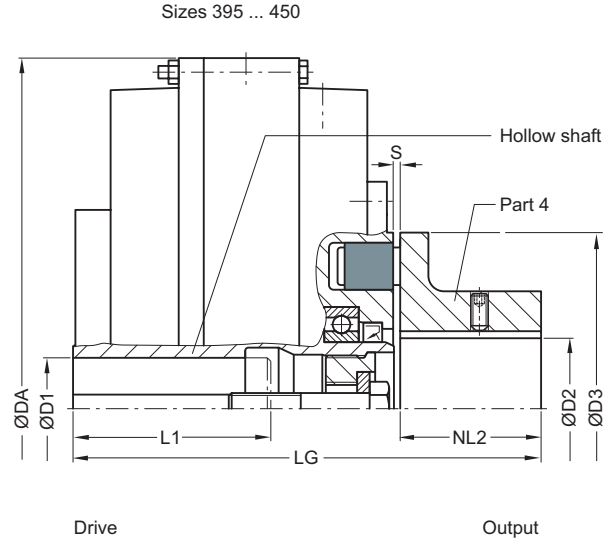
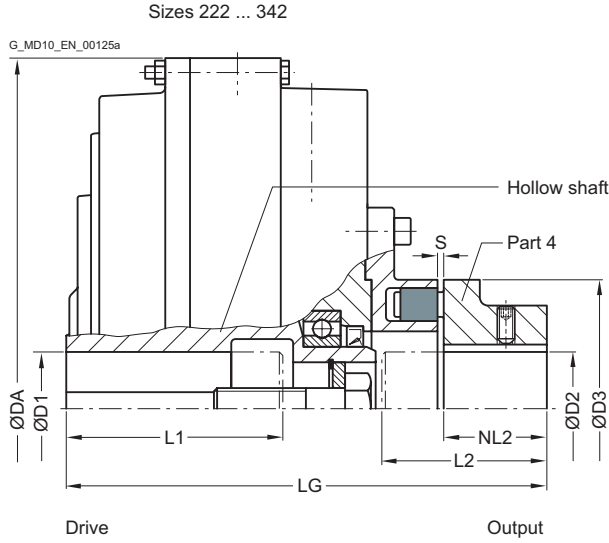

Size	Maximum speed n_{Kmax} rpm	FLUDEX coupling						N-EUPEX E add-on coupling					Article no. ¹⁾	Weight <i>m</i> kg
		D1 Keyway to DIN 6885			L1 max. mm	DA mm	LG mm	D2 max. mm	L2 max. mm	NL2 mm	Size D3 mm	S mm		
		min. mm	max. mm	Preferred bore mm										
222	3600	38	42 ²⁾	28	80	263	180	48	65	40	110	3 ⁺¹ ₋₁	2LC0900-0AB9	12
297	3600	38			80	340	233	55	80	50	125	3 ⁺¹ ₋₁	2LC0900-1AB9	24
		>38	55	42	110									
342	3600	>55 ²⁾	60 ²⁾	48 + 55	110	400	271	60	88	55	140	3 ⁺¹ ₋₁	2LC0900-2AB9	34
		55	60 ²⁾	120										
395	3000	65		60 + 65	140	448	299	90	90	90	225	4,5 ^{+1,5} _{-1,5}	2LC0900-3AB9	50
450	3000	75		65 + 75	140	512	338	100	100	100	250	6 ⁺² ₋₃	2LC0900-4AB9	68
		>75	80	170										

Configurable variants¹⁾

- ØD2 Without finished bore
With finished bore
- Delivery without oil filling
Delivery with oil filling with specification of oil filling quantity in l
Delivery without oil filling with oil filling quantity specification in l

Notes

- The specified coupling weights are effective for maximum bores without oil filling.
- Delivery with oil filling only above -20 °C

Ordering example

- Motor 45 kW, $P_{eff} = 42$ kW, $n_1 = 2950$ rpm
- FLUDEX FAE coupling size 342
- Hollow shaft: Bore ØD1 = 55H7 mm with keyway to DIN 6885/1 and retaining screw
- Part 4: Bore ØD2 = 60H7 mm with keyway to DIN 6885/1 and set screw
- with micro-balancing (high speed)
- with electronic operation monitoring
- seal set NBR
- Delivery without oil filling, no oil filling quantity specification

Article no. with EOC system:

2LC0900-2AB99-0AA0-Z L1D+M1E+F04+F26+W03+Y95

Plain text to Y95: G 6.3, n = 2950 rpm

¹⁾ To identify complete item numbers specifying the available finish boring options and – if necessary – further order options, please use our configurators on flender.com.

²⁾ Version with flat groove as per DIN 6885/3.

↗ For online configuration on flender.com, click on the item no.

TYPE FAM

with N-EUPEX M add-on coupling

Enables a short fitting length.

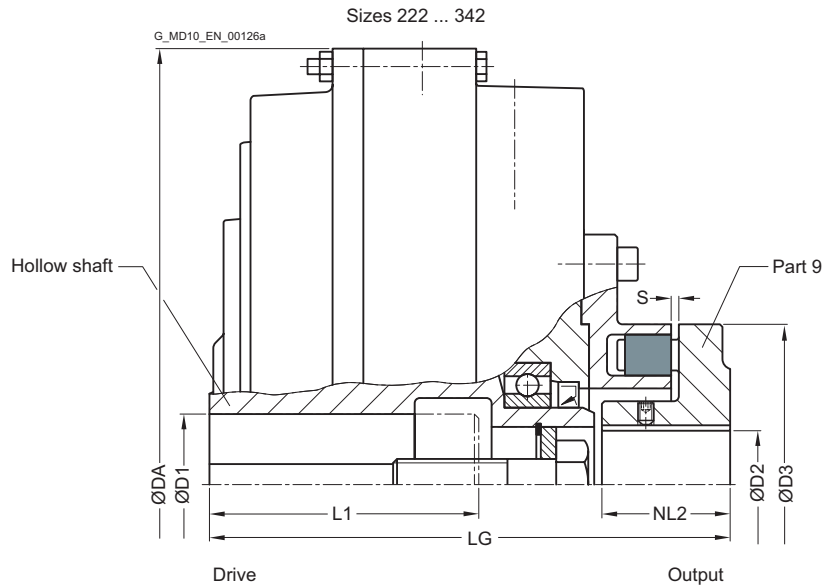

Size	Maximum speed n_{Kmax} rpm	FLUDEX coupling						N-EUPEX M add-on coupling				Article no. ¹⁾	Weight <i>m</i> kg
		D1 Keyway to DIN 6885			L1 max. mm	DA mm	LG mm	D2 max. mm	NL2 mm	Size D3 mm	S mm		
		min. mm	max. mm	Preferred bore mm									
222	3600		38	28	80	263	150	38	36	110	3 ⁺¹ ₋₁	2LC0900-0AH9	12
		>38 ²⁾	42 ²⁾										
297	3600		38		110	340	203	48	50	125	3 ⁺¹ ₋₁	2LC0900-1AH9	24
		>38 ²⁾	55	42									
342	3600		55	48 + 55	110	400	238	52	55	140	3 ⁺¹ ₋₁	2LC0900-2AH9	34
		>55 ²⁾	60 ²⁾										

Configurable variants¹⁾

- ØD2 Without finished bore
With finished bore
- Delivery without oil filling
Delivery with oil filling with specification of oil filling quantity in l
Delivery without oil filling with oil filling quantity specification in l

Notes

- The specified coupling weights are effective for maximum bores without oil filling.
- Delivery with oil filling only above -20 °C

¹⁾ To identify complete item numbers specifying the available finish boring options and – if necessary – further order options, please use our configurators on flender.com.

²⁾ Version with flat groove as per DIN 6885/3.

↗ For online configuration on flender.com, click on the item no.

Ordering example

- Motor 22 kW, $P_{eff} = 20$ kW, $n_1 = 1470$ rpm
- FLUDEX FAM coupling size 342
- Hollow shaft: Bore ØD1 = 40H7 mm with keyway to DIN 6885/1 and retaining screw
- Part 9: Bore ØD2 = 48H7 mm with keyway to DIN 6885/1 and set screw
- Delivery without oil filling, no oil filling quantity specification

Article no. with drive via housing:
2LC0900-2AH99-0AA0-Z L0W+M1B+F23

TYPE FADB

with N-EUPEX D add-on coupling and brake drum

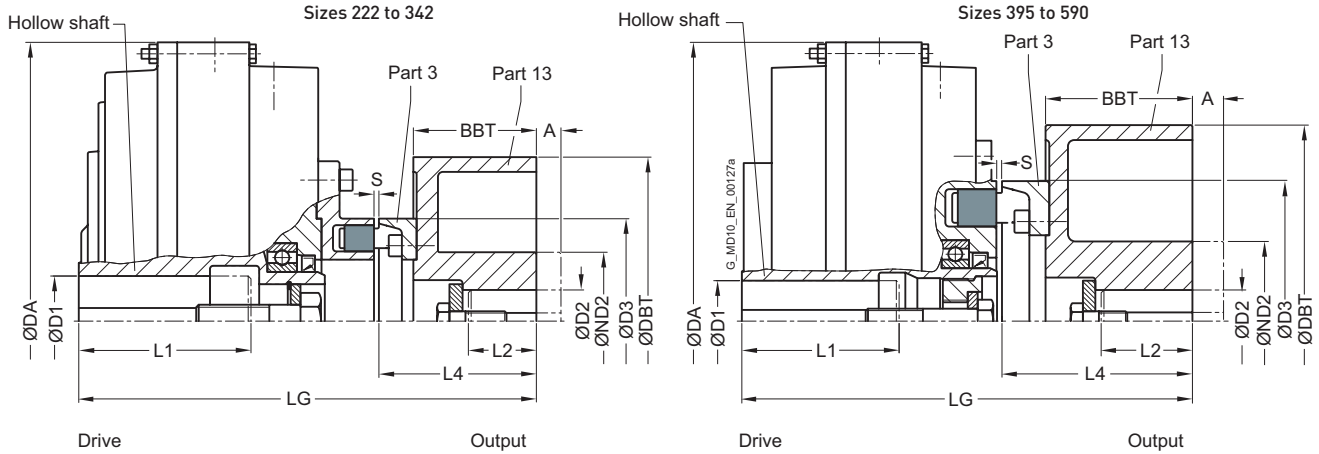

Size	Maximum speed n_{Kmax} rpm	FLUDEX coupling					N-EUPEX D add-on coupling			Brake drum [Part 13]					Article no. ¹⁾	Weight <i>m</i> kg
		D1 Keyway DIN 6885		L1	DA	LG	Size D3	S	L4	D2	ND2	DBT	BBT	A		
		min. mm	max. mm	max. mm	mm	mm	mm	mm	mm	max. mm	mm	mm	mm	mm		
222	3600	>38 ²⁾	38 42 ²⁾	80	263	232	110	3 ⁺¹ ₋₁	92	42	68	200	75	30	2LC0900-0AC9	17
297	3600	>38	38	80	340	279	125	3 ⁺¹ ₋₁	96	55	84	200	75	30	2LC0900-1AC9	29
		>55 ²⁾	60 ²⁾	110												
342	3600	>55 ²⁾	55 60 ²⁾	110 120	400	337	140	3 ⁺¹ ₋₁	121	60	128 ³⁾	250	95	50	2LC0900-2AC9	48
			55	110												
395	3000		65	140	448	362	225	4,5 ^{+1,5} _{-1,5}	153	80	128	315	118	50	2LC0900-3AC9	71
450	3000		75	140	512	395	250	6 ⁺² ₋₃	157	80	128	315	118	50	2LC0900-4AC9	86
		>75	80	170												
516	2300		55	140	584	466	315	5 ⁺³ ₋₂	193	100	160	400	150	80	2LC0900-5AC9	146
		>55	90	170												
590	1900		75	140	662	540	315	5 ⁺³ ₋₂	232	110	175	500	190	110	2LC0900-6AC9	207
		>75	95	170												
		>95	100	210												

Configurable variants ¹⁾

- ØD2 Without finished bore
With finished bore
- Part 13 Standard brake drum
Long brake drum
- Delivery without oil filling
Delivery with oil filling with specification of oil filling quantity in l
Delivery without oil filling with oil filling quantity specification in l

Notes

- The specified coupling weights are effective for maximum bores without oil filling, without hub prolongations "A" but with set screw
- L2 denotes the shaft insertion depth.
In the case of shaft ends deviating from DIN 748/1 long, the insertion depth must be specified in plain text with "Y29"
- Delivery with oil filling only above -20 °C

Ordering example

- Motor 30 kW, $P_{eff} = 22$ kW, $n_1 = 1470$ rpm
- FLUDEX FADB coupling size 342, standard type
- Hollow shaft: Bore ØD1 = 55H7 mm with keyway to DIN 6885/1 and retaining screw
- Brake drum (Part 13): Bore ØD2 = 50H7 mm with keyway to DIN 6885/1 and set screw.
- shaft end insertion depth L2 = 90 mm
- Delivery without oil filling, no oil filling quantity specification

Article no. Part 13 Standard brake drum:

2LC0900-2AC99-0AA0-Z L1D+M1C+Y29
Plain text to Y29: 90 mm

Article no. Part 13 Long brake drum:

2LC0900-2AC99-0BA0-Z L1D+M1C+Y29
Plain text to Y29: 90 mm

²⁾ Version with flat groove as per DIN 6885/3.

³⁾ ND2 = 128 for A = 0
ND2 = 100 for hub prolongations A = 50

↗ For online configuration on flender.com, click on the item no.

¹⁾ To identify complete item numbers specifying the available finish boring options and – if necessary – further order options, please use our configurators on flender.com.

TYPE FADS SB

with N-EUPEX D add-on coupling and brake disk for stopping brakes

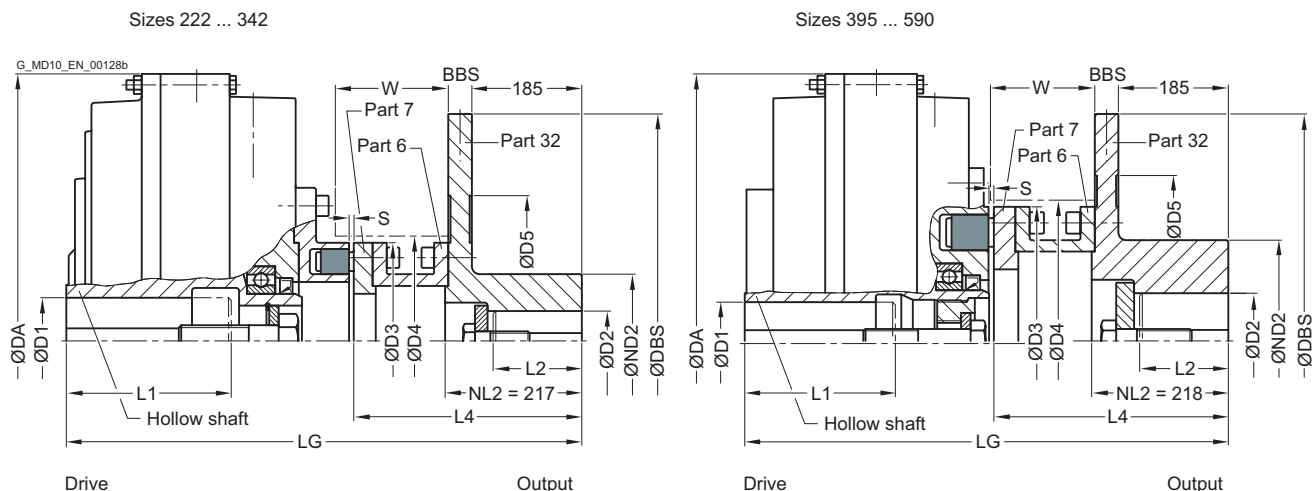

Size	Maximum speed n_{Kmax} rpm	FLUDEX coupling			N-EUPEX D add-on coupling			Brake disk (part 32) ²⁾					Space dimensions		Article no. ¹⁾	Weight m kg		
		D1 Keyway DIN 6885 min. mm	max. mm	L1 max. mm	DA mm	LG mm	Size D3 mm	S mm	L4 mm	D2 max. mm	ND2 mm	DBS mm	BBS mm	D5 mm			D4 mm	W mm
222	3600	38	42 ³⁾	80	263	494	110	5 ⁺¹	352	42	100	315	30	165	115	149	2LC0900-0AD9	35
		>38 ³⁾	55	80	340	537	125	5 ⁺¹	352	60	120	355	30	205	130	155		
297	3600	55	60 ³⁾	110	340	537	125	5 ⁺¹	352	60	120	355	30	205	130	155	2LC0900-1AD9	68
		>55 ³⁾	110	110	340	537	125	5 ⁺¹	352	60	120	355	30	205	130	155		
342	3300	55	60 ³⁾	110	400	570	140	5 ⁺¹	352	60	120	400	30	250	145	155	2LC0900-2AD9	83
		>55 ³⁾	120	120	400	570	140	5 ⁺¹	352	60	120	400	30	250	145	155		
395	3000	65	140	140	448	602	225	6 ⁺¹	391.5	80	150	450	30	300	230	182	2LC0900-3AD9	102
		75	140	140	448	602	225	6 ⁺¹	391.5	80	150	450	30	300	230	182		
450	2300	75	140	140	512	630.5	250	8 ⁺¹	390.5	90	160	560	30	370	260	182	2LC0900-4AD9	141
		>75	170	170	512	630.5	250	8 ⁺¹	390.5	90	160	560	30	370	260	182		
516	2100	55	140	140	584	706.5	315	8 ⁺¹	430.5	100	160	630	30	440	325	222	2LC0900-5AD9	199
		>55	170	170	584	706.5	315	8 ⁺¹	430.5	100	160	630	30	440	325	222		
590	2000	75	140	140	662	741.5	315	8 ⁺¹	430.5	100	160	630	30	440	325	222	2LC0900-6AD9	224
		>75	170	170	662	741.5	315	8 ⁺¹	430.5	100	160	630	30	440	325	222		
		>95	210	210														

Configurable variants¹⁾

- ØD2 Without finished bore
With finished bore
- Delivery without oil filling
Delivery with oil filling with specification of oil filling quantity in l
Delivery without oil filling with oil filling quantity specification in l

Notes

- The specified coupling weights are effective for maximum bores without oil filling.
- L2 denotes the shaft insertion depth.
In the case of shaft ends deviating from DIN 748/1 long, the insertion depth must be specified in plain text with "Y29"
- Delivery with oil filling only above -20 °C

Ordering example

- Motor 90 kW, $P_{eff} = 75$ kW, $n_1 = 1470$ rpm
- FLUDEX FADS SB coupling size 450
- Hollow shaft: Bore ØD1 = 75H7 mm with keyway to DIN 6885/1 and retaining screw
- Brake disk (part 32): Bore ØD2 = 80H7 mm with keyway to DIN 6885/1 and retaining screw
- with preservation suitable for indoor storage
- shaft end insertion depth L2 = 90 mm
- Delivery without oil filling, no oil filling quantity specification

Article no. with preservation 24 months:

2LC0900-4AD99-0AA0-Z L1H+M1J+B28+Y29

Plain text to Y29: L2 = 90 mm

¹⁾ To identify complete item numbers specifying the available finish boring options and – if necessary – further order options, please use our configurators on flender.com.

²⁾ Hub shortening possible, clearly specify NL2 size

³⁾ Version with flat groove as per DIN 6885/3.

↗ For online configuration on flender.com, click on the item no.

TYPE FADS HB

with N-EUPEX D add-on coupling and brake disk for blocking brakes

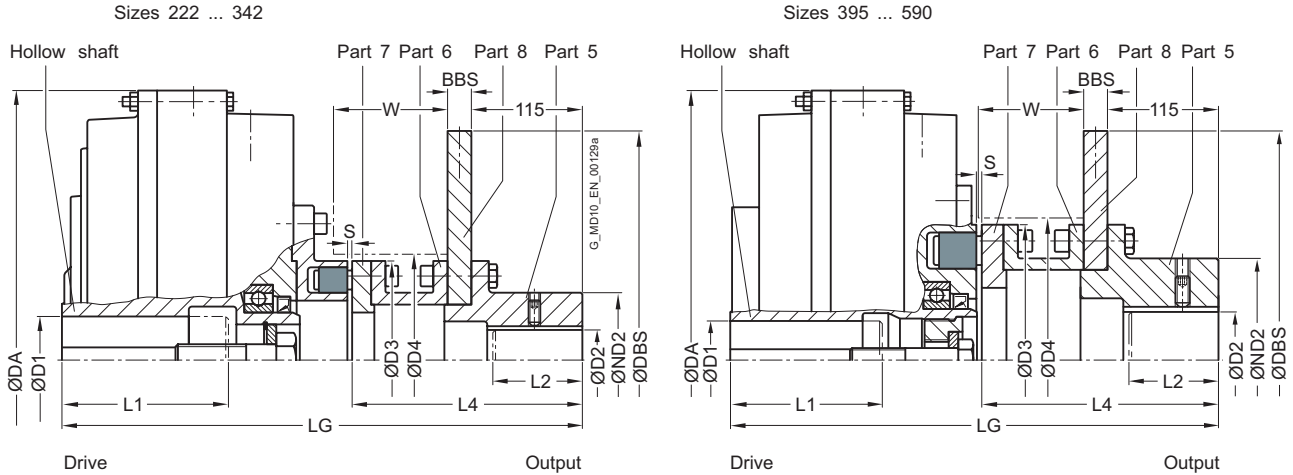

Size	Maximum speed n_{Kmax} rpm	FLUDEX coupling			N-EUPEX D add-on coupling			Brake disk (part 5/8)				Space dimensions		Article no. ¹⁾	Weight <i>m</i> kg		
		D1 Keyway DIN 6885 min. mm	max. mm	L1 max. mm	DA mm	LG mm	Size D3 mm	S mm	L4 mm	D2 max. mm	ND2 mm	DBS mm	BBS mm			D4 mm	W mm
222	3600	38	42 ²⁾	80	263	366.5	110	5 ⁺¹	224.5	42	70	250	12.5	115	109	2LC0900-0AE9	22
		>38 ²⁾	38	80													
297	3600	55	60 ²⁾	110	340	409.5	125	5 ⁺¹	224.5	60	85	250	12.5	130	115	2LC0900-1AE9	33
		>55 ²⁾	60 ²⁾	110													
342	3600	55	60 ²⁾	110	400	442.5	140	5 ⁺¹	224.5	60	90	250	12.5	145	115	2LC0900-2AE9	45
		>55 ²⁾	60 ²⁾	120													
395	3000	65	75	140	448	478	225	6 ⁺¹	267.5	80	150	355	16	230	142	2LC0900-3AE9	80
450	2750	75	80	170	512	546.5	250	8 ⁺¹	306.5	90	160	355	16	260	182	2LC0900-4AE9	101
516	2150	55	75	140	584	566.5	315	8 ⁺¹	290.5	100	160	450	16	325	166	2LC0900-5AE9	154
		>55	90	170													
590	2000	75	95	170	662	601.5	315	8 ⁺¹	290.5	100	160	450	16	325	166	2LC0900-6AE9	179
		>75	100	210													

Configurable variants¹⁾

- ØD2 Without finished bore
With finished bore
- Delivery without oil filling
Delivery with oil filling with specification of oil filling quantity in l
Delivery without oil filling with oil filling quantity specification in l

Notes

- The specified coupling weights are effective for maximum bores without oil filling.
- L2 denotes the shaft insertion depth.
In the case of shaft ends deviating from DIN 748/1 long, the insertion depth must be specified in plain text with "Y29"
- Delivery with oil filling only above -20 °C

Ordering example

- Motor 160 kW, $P_{eff} = 132$ kW, $n_1 = 2950$ rpm
- FLUDEX FADS HB coupling size 395
- Hollow shaft: Bore ØD1 = 65H7 mm with keyway to DIN 6885/1 and retaining screw
- Part 5: Bore ØD2 = 80H7 mm with keyway to DIN 6885/1 and set screw
- Delivery without oil filling, no oil filling quantity specification

Article no.: 2LC0900-3AE99-0AA0-Z L1F+M1J+W03+Y95
Plain text to Y95: G 6.3, n = 1500 rpm

¹⁾ To identify complete item numbers specifying the available finish boring options and – if necessary – further order options, please use our configurators on flender.com.

²⁾ Version with flat groove as per DIN 6885/3.

➤ For online configuration on flender.com, click on the item no.

OIL FILLING QUANTITIES FOR FA SERIES

This assignment is valid for a maximum starting torque $T_{max} = 2.0 \cdot T_{eff}$ and mineral oils with a viscosity of VG 22/VG 32, with drive via the hollow shaft.

If other operating fluids are used, or with drive via the housing or $T_{max} \neq 2.0 \cdot T_{eff}$, changed filling quantities must be observed!

Sizes 222, 342, 450 and 590											
P_{eff} kW	Speed in rpm										Size
	600	740	890	980	1180	1470	1770	2300	2950	3550	
Oil filling quantity in l											
0.55	4.3		1.4	1.3	1.1						
0.75	4.7		1.5	1.4	1.2						
1.1	5.1	4.4	1.55	1.55	1.4	1.1					
2.2	6.2	5.2	4.5	4.2	1.55	1.4	1.2				
3	9.5	5.6	4.9	4.6	1.55	1.5	1.3	1			
4	10.2	6.1	5.3	4.9	4.3	1.55	1.4	1.1			
5.5	11	9.4	5.7	5.3	4.6	1.55	1.5	1.2	1		
7.5	12	10.2	6.2	5.8	5	4.3	1.55	1.3	1.1		
11	13.4	11.2	9.7	6.4	5.5	4.7	4.1	1.5	1.2	1	
15	24.8	12.2	10.5	9.8	6	5	4.4	1.55	1.3	1.1	
18	25.9	12.9	11	10.3	6.3	5.3	4.6	3.9	1.4	1.2	
22	27.3	23.3	11.6	10.8	9.4	5.5	4.8	4	1.4	1.25	
30	29.7	25.2	12.7	11.7	10.1	6	5.2	4.3	3.7	1.4	
37	31.5	26.5	23.1	12.4	10.7	9.1	5.5	4.5	3.9	1.5	
45		27.9	24.2	22.6	11.2	9.5	5.8	4.7	4	3.5	
55		29.5	25.5	23.7	11.9	10	8.8	5	4.2	3.7	
75			27.6	25.7	22.3	10.8	9.4	5.4	4.5	3.9	
90			29	26.9	23.4	11.3	9.8	8.1	4.7	4.1	
110				28.3	24.5	12	10.4	8.6	4.9	4.3	
132				29.7	25.7	21.9	10.8	8.9	7.6	4.5	
160					27	22.9	20	9.3	7.8		
180					27.8	23.5	20.6	10	8		
200					28.6	24.2	21.2	10.9	8.2		
225						24.9	21.8	11.5	8.5		
250						25.6	22.3		9.6		
280						26.3	22.9		9.9		
315						27.1	23.6		10.5		
350							24.2				
400							26.4				

Sizes 297, 395 and 516											
P_{eff} kW	Speed in rpm										Size
	600	740	890	980	1180	1470	1770	2300	2950	3550	
	Oil filling quantity in l										
0.55	3.2	2.8									
0.75	3.5	3	2.6								
1.1	3.7	3.3	2.9	2.7							
2.2	7.3	3.7	3.4	3.2	2.8						
3	7.9	6.8	3.7	3.4	3	2.5					
4	8.5	7.3	3.7	3.7	3.2	2.7					
5.5	9.4	7.9	6.8	3.7	3.5	2.9	2.6				
7.5	17	8.5	7.4	6.9	3.7	3.2	2.8	2.4			
11	18.7	16	8.1	7.6	6.6	3.5	3	2.5			
15	20.3	17.3	8.9	8.2	7.1	3.7	3.3	2.7			
18	21.4	18	15.7	8.6	7.4	3.7	3.4	2.8	2.4		
22		19	16.5	15.4	7.8	6.6	3.6	3	2.5		
30		20.6	17.8	16.6	8.5	7.2	6.3	3.2	2.7	2.4	
37			18.8	17.5	15.2	7.6	6.6	3.4	2.8	2.5	
45			19.8	18.4	16	7.9	6.9	3.6	2.9	2.6	
55			21	19.3	16.8	8.4	7.3	6	3.1	2.7	
75				21.1	18.1	15.4	7.9	6.5	5.3	2.9	
90					19	16.1	14.1	6.7	5.6	3	
110					20.1	16.9	14.8	7.1	5.9		
132						17.7	15.4	7.9	6.2		
160						18.6	16.2	13.4	6.8		
180						19.2	16.7	13.8	7.2		
200							17.1	14.1			
225							17.6	14.6			
250							18.1	14.9			
280								15.3			
315								15.8			
350								17.1			

TYPE FGO

Basic coupling of the FG series with connecting flange

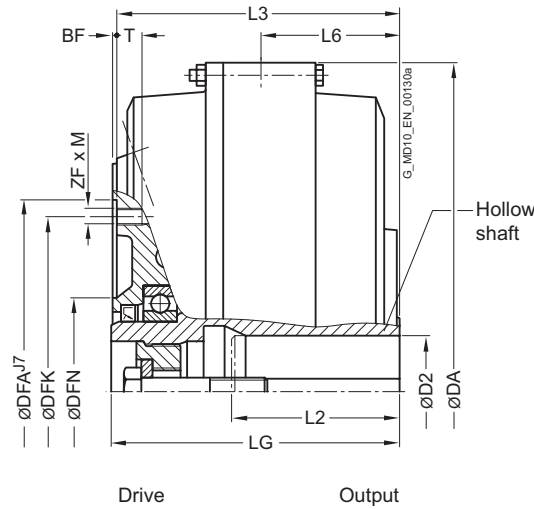

Size	Maximum speed n_{Kmax} rpm	Installation dimensions								Flange connection dimensions					Tightening torque for screws in thread ZF · M T_A Nm	Article no. ¹⁾	Weight m kg
		D2 Keyway DIN 6885		L2 max. mm	DA mm	L3 mm	L6 mm	LG mm	DFN mm	DFA mm	BF mm	DFK mm	ZF · M	T mm			
		min. mm	max. mm														
370	3600	75	140	420	182	84	185	126	220	3	200	8 · M10	15	31	2LC0900-8CE09-0AA0	34	
425	3000	80	140	470	202	99	205	134	274	3	250	8 · M12	18	54	2LC0901-0CE09-0AA0	45	
		55	110														
490	2600	>55	75	140	555	232	105	236	150	314	4	282	8 · M16	24	135	2LC0901-1CE09-0AA0	75
		>75	100	170													
565	2300	110	170	630	250	123	254	166	344	4	312	8 · M16	24	135	2LC0901-2CE09-0AA0	95	
655	2000	130	210	736	296	145	301	180	430	5	390	8 · M20	25	260	2LC0901-3CE09-0AA0	142	
755	1800	150	240	840	341	176	346	226	480	5	440	10 · M20	25	260	2LC0901-4CE09-0AA0	208	
887	1500	150	275	990	391	217	396	249	520	5	480	10 · M20	25	260	2LC0901-5CE09-0AA0	362	

Configurable variants ¹⁾

- Delivery without oil filling
Delivery with oil filling with specification of oil filling quantity in l
Delivery without oil filling with oil filling quantity specification in l

Notes

- The specified coupling weights are effective for maximum bores without oil filling.
- Delivery with oil filling only above -20 °C

Ordering example

- Motor 132 kW, $P_{eff} = 110$ kW, $n_1 = 1470$ rpm
- FLUDEX FGO coupling size 490
- Hollow shaft: Bore $\varnothing D2 = 70H7$ mm with keyway to DIN 6885/1 and retaining screw
- Delivery with oil filling: 14.4 l (see Page 13/9)

Article no.: 2LC0901-1CE09-0AA0-Z L1G+F16+Y90

Plain text to Y90: 14.4 l

¹⁾ To identify complete item numbers specifying the available finish boring options and – if necessary – further order options, please use our configurators on flender.com.

↗ For online configuration on flender.com, click on the item no.

TYPE FGD

with N-EUPEX D add-on coupling

Enables change of flexible elements without axial displacement of the shafts if the space "A" is provided.

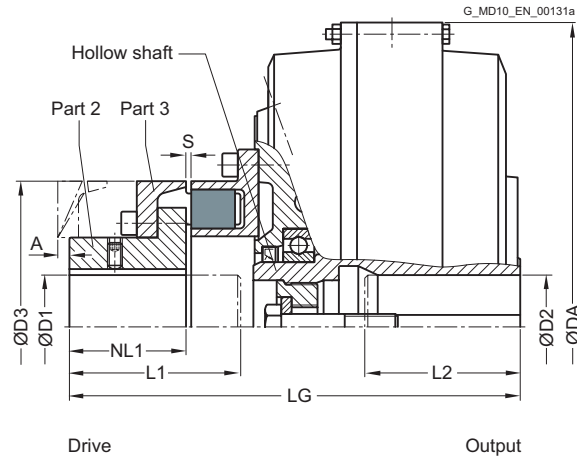

Size	Maximum speed n_{Kmax} rpm	FLUDEX coupling					N-EUPEX D add-on coupling						Article no. ¹⁾	Weight <i>m</i> kg
		D2 Keyway DIN 6885 min. mm max. mm		L2 max. mm	DA mm	LG mm	D1 max. mm	L1 max. mm	NL1 mm	Size D3 mm	S mm	A mm		
370	3600	75	140	420	298	65	110	70	180	4 ⁺² ₋₂	10	2LC0900-8CA	44	
425	3000	80	140	470	348	85	140	90	225	4 ⁺² ₋₂	9	2LC0901-0CA	66	
490	2600	55	110	555	397	95	155	100	250	5 ⁺³ ₋₂	11	2LC0901-1CA	105	
		>55 >75	75 100											140 170
565	2300	110	170	630	430	105	170	110	280	5 ⁺³ ₋₂	5	2LC0901-2CA	134	
655	2000	130	210	736	515	140	210	140	350	5 ⁺³ ₋₂	0	2LC0901-3CA	217	
755	1800	150	240	840	584	150	230	160	400	5 ⁺³ ₋₂	0	2LC0901-4CA	307	
887	1500	150	275	990	665	160	260	180	440	8 ⁺² ₋₃	0	2LC0901-5CA	491	

Configurable variants¹⁾

- ØD1 Without finished bore
With finished bore
- Delivery without oil filling
Delivery with oil filling with specification of oil filling quantity in l
Delivery without oil filling with oil filling quantity specification in l

Notes

- The specified coupling weights are effective for maximum bores without oil filling.
- Delivery with oil filling only above -20 °C

¹⁾ To identify complete item numbers specifying the available finish boring options and – if necessary – further order options, please use our configurators on flender.com.

↗ For online configuration on flender.com, click on the item no.

Ordering example

- Motor 350 kW, $P_{eff} = 315$ kW, $n_1 = 1470$ rpm
- FLUDEX FGD coupling size 655, standard type
- Hollow shaft: Bore ØD2 = 120H7 mm with keyway to DIN 6885/1 and retaining screw
- Part 2: without finished bore (bore ØD1 = 110 mm or ØD1 = 130 mm) or with finished bore (bore ØD1 = 140H7 mm) with keyway to DIN 6885/1 and set screw
- Delivery without oil filling, no oil filling quantity specification

Article no. without finished bore for ØD1 = 110 mm:
2LC0901-3CA19-0AA0-Z L1S

Article no. without finished bore for ØD1 = 130 mm:
2LC0901-3CA29-0AA0-Z L1S

Article no. with finished bore for ØD1 = 140H7 mm:
2LC0901-3CA99-0AA0-Z L1S+M1V

TYPE FGE

with N-EUPEX E add-on coupling

Enables larger bores on the drive side.

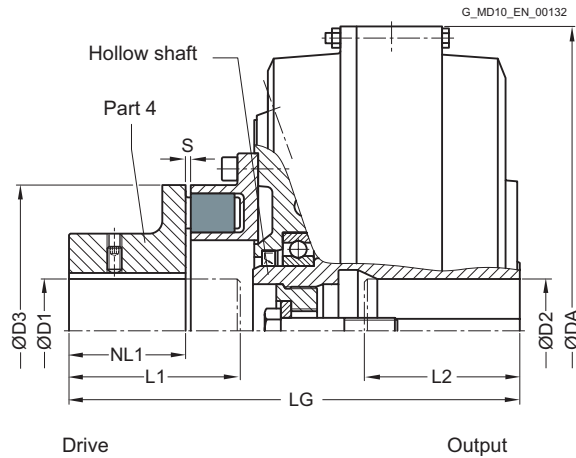

Size	Maximum speed n_{Kmax} rpm	FLUDEX coupling					N-EUPEX E add-on coupling					Article no. ¹⁾	Weight <i>m</i> kg
		D2 Keyway DIN 6885		L2	DA	LG	D1	L1	NL1	Size D3	S		
		min. mm	max. mm	max. mm	mm	mm	max. mm	max. mm	mm	mm	mm		
370	3600	75		140	420	298	75	110	70	180	4 ⁺² ₋₂	2LC0900-8CB	44
425	3000	80		140	470	348	90	140	90	225	4 ⁺² ₋₂	2LC0901-0CB	64
490	2600	55		110	555	397	100	155	100	250	5 ⁺³ ₋₂	2LC0901-1CB	101
		>55	75	140									
		>75	100	170									
565	2300	110		170	630	430	110	170	110	280	5 ⁺³ ₋₂	2LC0901-2CB	129

13

Configurable variants ¹⁾

- ØD1 Without finished bore
With finished bore
- Delivery without oil filling
Delivery with oil filling with specification of oil filling quantity in l
Delivery without oil filling with oil filling quantity specification in l

Notes

- The specified coupling weights are effective for maximum bores without oil filling.
- Delivery with oil filling only above -20 °C

Ordering example

- Motor 160 kW, $P_{eff} = 145$ kW, $n_1 = 1485$ rpm
- FLUDEX FGE coupling size 490, vertical version, motor overhead
- Hollow shaft: Bore ØD2 = 60H7 with keyway to DIN 6885/1 and retaining screw
- Part 4: Bore ØD2 = 80H7 with keyway to DIN 6885/1 and set screw
- with seal set FPM
- Delivery with oil filling with specification of oil filling quantity

Article no.: 2LC0901-1CB99-0AA0-Z L1J+M1E+F08+F13+F16+Y90
Plain text to Y90: 15.4 l

¹⁾ To identify complete item numbers specifying the available finish boring options and – if necessary – further order options, please use our configurators on flender.com.

↗ For online configuration on flender.com, click on the item no.

TYPE FGM

with N-EUPEX M add-on coupling

Enables a short fitting length.

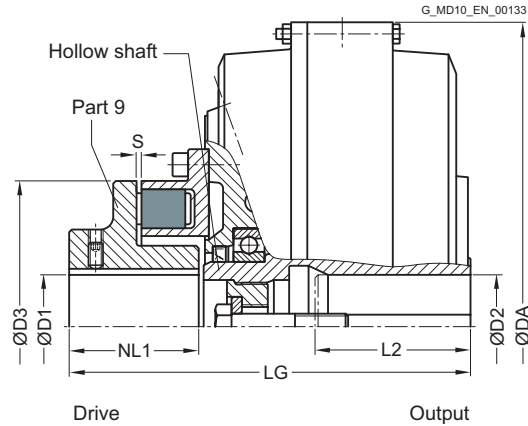

Size	Maximum speed n_{Kmax} rpm	FLUDEX coupling					N-EUPEX M add-on coupling					Article no. ¹⁾	Weight m kg	
		D2 Keyway DIN 6885		L2	DA	LG	D1	L1	NL1	Size D3	S			
		min. mm	max. mm	max. mm	mm	mm	max. mm	max. mm	mm	mm	mm	mm		
370	3600	75	140	420	274	70	80	80	180	4 ⁺² ₋₂	2LC0900-8CD	44		
425	3000	55	110	555	350	90	105	105	250	5 ⁺³ ₋₂	2LC0901-0CD	64		
		80	140										85	100
490	2600	>55	75	140	555	350	90	105	105	250	5 ⁺³ ₋₂	2LC0901-1CD	101	
		>75	100	170										
565	2300	110	170	630	380	100	120	120	280	5 ⁺³ ₋₂	2LC0901-2CD	128		

Configurable variants¹⁾

- ØD1 Without finished bore
With finished bore
- Delivery without oil filling
Delivery with oil filling with specification of oil filling quantity in l
Delivery without oil filling with oil filling quantity specification in l

Notes

- The specified coupling weights are effective for maximum bores without oil filling.
- Delivery with oil filling only above -20 °C

Ordering example

- Motor 45 kW, $P_{eff} = 37$ kW, $n_1 = 1470$ rpm
- FLUDEX FGM coupling size 370
- Hollow shaft: Bore ØD2 = 60H7 mm with keyway to DIN 6885/1 and retaining screw
- Part 4: Bore ØD1 = 60H7 mm with keyway to DIN 6885/1 and set screw.
- Delivery without oil filling, no oil filling quantity specification

Article no. with a keyway: 2LC0900-8CD99-0AA0-Z L1E+M1E

¹⁾ To identify complete item numbers specifying the available finish boring options and – if necessary – further order options, please use our configurators on flender.com.

➤ For online configuration on flender.com, click on the item no.

OIL FILLING QUANTITIES FOR FG SERIES

This assignment is valid for a maximum starting torque $T_{max} = 2.0 \cdot T_{eff}$ and mineral oils with a viscosity of VG 22/VG 32.

If other operating fluids are used, or with drive via the hollow shaft or $T_{max} \neq 2.0 \cdot T_{eff}$ or $T_{max} \neq 1.5 \cdot T_{eff}$, changed filling quantities must be observed!

Sizes 370, 490, 655 and 887											
P_{eff} kW	Speed in rpm										Size
	600	740	890	980	1180	1470	1770	2300	2950	3550	
Oil filling quantity in l											
1.1	5.2										
2.2	6.4										
3	7	5.9									
4	7.2	6.4	5.4								
5.5	13	6.9	6	5.4							
7.5	14.4	7.2	6.5	6	5.1						
11	15.9	13.3	7.2	6.7	5.7						
15	17	14.7	12.4	7.2	6.2						
18	28.9	15.4	13.1	12	6.5	5.4					
22	31.1	16.2	14	12.7	6.9	5.7	4.7				
30	35.9	17	15.2	14.1	11.8	6.3	5.3				
37	37.9	29.9	16.1	14.9	12.6	6.6	5.7				
45	39.7	32.3	17	15.7	13.4	7	6				
55	40	35.5	28.4	16.6	14.3	11.6	6.4	5			
75	70.5	38.7	31.7	28.5	15.5	12.7	6.9	5.5	4.3		
90	74.7	40	34.4	30.4	16.3	13.5	11.4	5.9	4.6		
110	81	40	37	33	27.3	14.4	12.1	6.2	4.9	4	
132	88.2	69.3	38.8	36	28.6	15.1	12.8	6.5	5.2	4.4	
160	93.5	73.3	40	37.8	30.6	15.9	13.6	10.6	5.5	4.7	370
200	98	79.8	67	39.9	33.7	26.9	14.6	11.4	6	5	
250	98	88.7	70.9	40	36.8	28.4	15.4	12.2		5.4	
315		94.7	76.6	69.8	39	30.8	26.2	13.1			490
350		97.2	80	71.8	39.9	32.2	26.9	13.6			
400		98	85.1	75.2	64.5	34.2	27.8				
500			92.4	82.5	68.1	37.1	29.7				655
600			96.9	90.1	71.5	38.8	31.9				
750			98	95.3	77.3	64	35.4				
900				98	83.7	67					
1100					91.1	70.4					887
1300					95.2	74.2					
1600						80.6					

Sizes 425, 565 and 755										
P_{eff} kW	Speed in rpm								Size	
	600	740	890	980	1180	1470	1770	2300		2950
	Oil filling quantity in l									
2.2	7.8									
3	8.7									
4	9.5	7.8								
5.5	10.3	8.7								
7.5	10.9	9.5	7.9							
11	19.9	10.5	9.1	8.2						
15	22	10.9	9.8	9.1						
18	23.2	19.1	10.3	9.6	8					
22	24.3	20.3	10.9	10.1	8.6					
30	40.2	22.4	18.9	10.9	9.5					
37	42.6	23.7	20.1	18.5	10	8.2				
45	45.8	24.9	21.5	19.5	10.5	8.8				
55	50.1	25.5	22.8	20.8	17.5	9.3	7.8			
75	55.6	43.8	24.6	22.9	19.3	10.1	8.6			
90	58.1	47.1	25.5	23.9	20.4	10.7	9.2	7.2		
110		51.7	41.5	25.5	21.8	17.7	9.7	7.6		
132		54.7	44	40.3	23	18.7	10.1	8.1	6.3	
160		57.4	47.5	42.5	24	19.8	16.7	8.6	6.8	
200		59	52.9	46.2	25.5	21.4	17.9	9.2	7.3	425
250			56	51.2	41.2	22.8	19.2	14.6	7.8	
315			59	55.1	44.4	24.2	20.6	16.1	8.3	
350				56.6	46.2	38	21.4	16.7		
400				58.4	49	39.3	22.2	17.4		565
500					53.7	41.6	36.3	18.7		
600					56.4	44.1	37.9			
750						48.4	40			755
900						52.8	42			
1100							45			

TYPE FVO

Delay chamber coupling of the FV series with connecting flange.

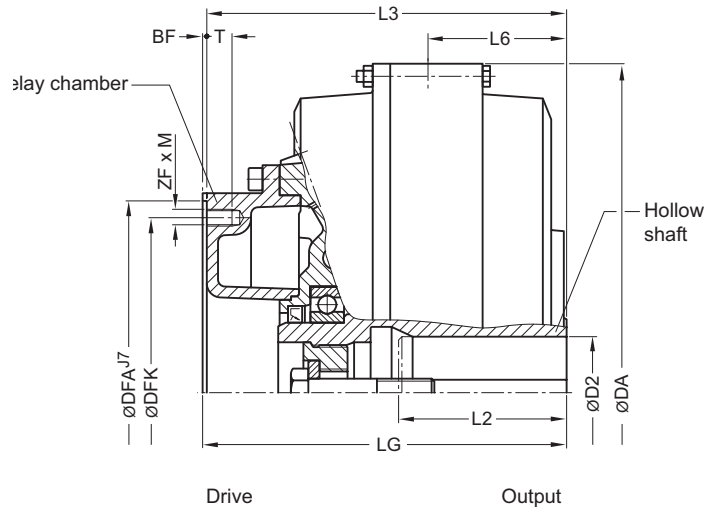

Size	Maximum speed n_{Kmax} rpm	Installation dimensions							Flange connection dimensions					Tightening torque for screws in thread ZF · M T_A Nm	Article no. ¹⁾	Weight m kg
		D2 Keyway DIN 6885		L2 max. mm	DA mm	L3 mm	L6 mm	L8 mm	DFA mm	BF mm	DFK mm	ZF · M	T mm			
		min. mm	max. mm													
370	3600	75	140	420	225	84	228	220	3	200	8 · M10	15	31	2LC0900-8ED09-0AA0	37	
425	3000	80	140	470	257	99	260	274	3	250	8 · M12	18	54	2LC0901-0ED09-0AA0	47	
490	2600	55	140	555	297	105	301	314	4	282	8 · M16	24	135	2LC0901-1ED09-0AA0	80	
		75														110
565	2300	110	170	630	333	123	337	344	4	312	8 · M16	24	135	2LC0901-2ED09-0AA0	103	
655	2000	130	210	736	384	145	389	430	5	390	8 · M20	25	260	2LC0901-3ED09-0AA0	154	
755	1800	150	240	840	440	176	445	480	5	440	10 · M20	25	260	2LC0901-4ED09-0AA0	224	
887	1500	150	275	990	493	217	498	520	5	480	10 · M20	25	260	2LC0901-5ED09-0AA0	385	

Configurable variants ¹⁾

- Delivery without oil filling
Delivery with oil filling with specification of oil filling quantity in l
Delivery without oil filling with oil filling quantity specification in l

Notes

- The specified coupling weights are effective for maximum bores without oil filling.
- Delivery with oil filling only above -20 °C

Ordering example

- Motor 132 kW, $P_{eff} = 110$ kW, $n_1 = 1470$ rpm
- FLUDEX FVO coupling size 490
- Hollow shaft: Bore $\varnothing D2 = 70H7$ mm with keyway to DIN 6885/1 and retaining screw
- Delivery with oil filling: 15.2 l (see Page 13/9)

Article no.: 2LC0901-1ED09-0AA0-Z L1G+F16+Y90

Plain text to Y90: 15.2 l

¹⁾ To identify complete item numbers specifying the available finish boring options and – if necessary – further order options, please use our configurators on flender.com.

↗ For online configuration on flender.com, click on the item no.

TYPE FVD

with N-EUPEX D add-on coupling

Enables change of flexible elements without axial displacement of the shafts if the space "A" is provided.

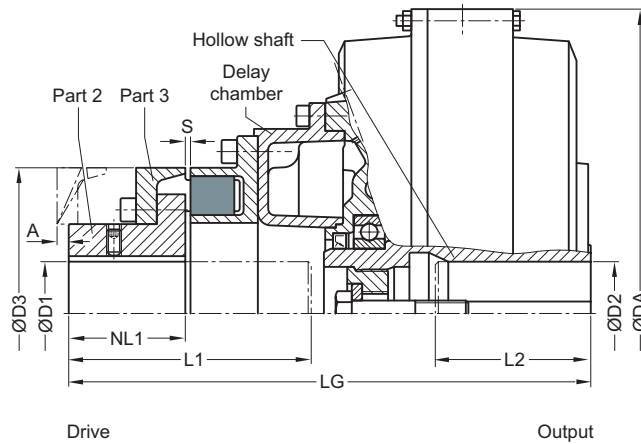

Size	Maximum speed n_{Kmax} rpm	FLUDEX coupling					N-EUPEX D add-on coupling						Article no. ¹⁾	Weight <i>m</i> kg
		D2 Keyway DIN 6885		L2	DA	LG	D1	L1	NL1	Size D3	S	A		
		min. mm	max. mm	max. mm	mm	mm	max. mm	max. mm	mm	mm	mm	mm		
370	3600	75	140	420	341	65	150	70	180	4 ⁺² ₋₂	10	2LC0900-8EA	47	
425	3000	80	140	470	403	85	190	90	225	4 ⁺² ₋₂	9	2LC0901-0EA	68	
490	2600	55	110	555	462	95	220	100	250	5 ⁺³ ₋₂	11	2LC0901-1EA	166	
		>55	75											140
		>75	100	170										
565	2300	110	170	630	513	105	250	110	280	5 ⁺³ ₋₂	5	2LC0901-2EA	142	
655	2000	130	210	736	603	140	295	140	350	5 ⁺³ ₋₂	0	2LC0901-3EA	229	
755	1800	150	240	840	683	150	330	160	400	5 ⁺³ ₋₂	0	2LC0901-4EA	323	
887	1500	150	275	990	767	160	365	180	440	8 ⁺² ₋₃	0	2LC0901-5EA	514	

Configurable variants¹⁾

- ØD1 Without finished bore
With finished bore
- Delivery without oil filling
Delivery with oil filling with specification of oil filling quantity in l
Delivery without oil filling with oil filling quantity specification in l

Notes

- The specified coupling weights are effective for maximum bores without oil filling.
- Delivery with oil filling only above -20 °C

Ordering example

- Motor 630 kW, $P_{eff} = 500$ kW, $n_1 = 1770$ rpm
- FLUDEX FVD coupling size 655
- Hollow shaft: Bore ØD2 = 95H7 with keyway to DIN 6885/1 and retaining screw,
- Part 2: Bore ØD2 = 110H7 with keyway to DIN 6885/1 and set screw
- with seal set FPM
- Delivery without oil filling with oil filling quantity specification [see Page 13/9]

Article no.: 2LC0901-3EA99-0AA0-Z L1Q+M1M+F08+Y90
Plain text to Y90: 32.3 l

¹⁾ To identify complete item numbers specifying the available finish boring options and – if necessary – further order options, please use our configurators on flender.com.

↗ For online configuration on flender.com, click on the item no.

TYPE FVE

with N-EUPEX E add-on coupling

Enables larger bores on the drive side.

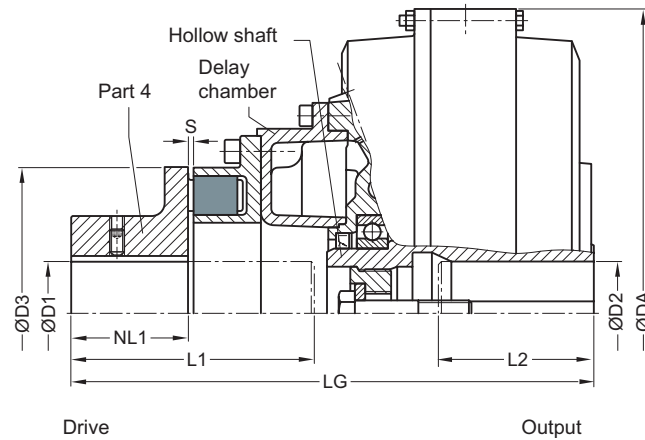

Size	Maximum speed n_{Kmax} rpm	FLUDEX coupling					N-EUPEX E add-on coupling					Article no. ¹⁾	Weight <i>m</i> kg
		D2 Keyway DIN 6885		L2	DA	LG	D1	L1	NL1	Size D3	S		
		min. mm	max. mm	max. mm	mm	mm	max. mm	max. mm	mm	mm	mm		
370	3600	75	140	140	420	341	75	150	70	180	4 ⁺² ₋₂	2LC0900-8EB	47
425	3000	80	140	140	470	403	90	190	90	225	4 ⁺² ₋₂	2LC0901-0EB	66
490	2600	55	110	140	555	462	100	220	100	250	5 ⁺³ ₋₂	2LC0901-1EB	107
		>55	75										
		>75	100	170									
565	2300	110	170	170	630	513	110	250	110	280	5 ⁺³ ₋₂	2LC0901-2EB	137

13

Configurable variants ¹⁾

- ØD1 Without finished bore
With finished bore
- Delivery without oil filling
Delivery with oil filling with specification of oil filling quantity in l
Delivery without oil filling with oil filling quantity specification in l

Notes

- The specified coupling weights are effective for maximum bores without oil filling.
- Delivery with oil filling only above -20 °C

Ordering example

- Motor 45 kW, $P_{eff} = 37$ kW, $n_1 = 1470$ rpm
- FLUDEX FVE coupling size 370
- Hollow shaft: Bore ØD2 = 60H7 mm with keyway to DIN 6885/1 and retaining screw
- Part 4: Bore ØD1 = 60H7 mm with keyway to DIN 6885/1 and set screw
- with electronic or mechanical operation monitoring, seal set NBR
- Delivery without oil filling, no oil filling quantity specification

Article no, with 110 °C thermal switch:
2LC0900-8EB99-0AA0-Z L1E+M1E+F03

Article no. with 125 °C EOC transmitter:
2LC0900-8EB99-0AA0-Z L1E+M1E+F04

¹⁾ To identify complete item numbers specifying the available finish boring options and – if necessary – further order options, please use our configurators on flender.com.

↗ For online configuration on flender.com, click on the item no.

TYPE FVM

with N-EUPEX M add-on coupling

Enables a short fitting length.

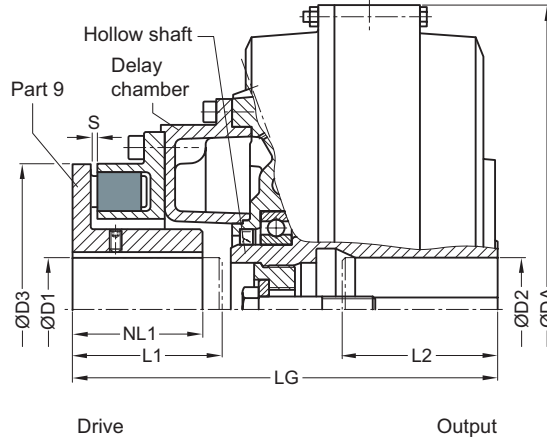

Size	Maximum speed n_{Kmax} rpm	FLUDEX coupling					N-EUPEX M add-on coupling					Article no. ¹⁾	Weight <i>m</i> kg
		D2 Keyway DIN 6885 min. mm max. mm		L2 max. mm	DA mm	LG mm	D1 max. mm	L1 max. mm	NL1 mm	Size D3 mm	S mm		
370	3600	75		140	420	288	70	100	85	180	4 ⁺² ₋₂	2LC0900-8EC	46
425	3000	80		140	470	327	85	115	100	225	4 ⁺² ₋₂	2LC0901-0EC	65
490	2600	55		110	555	382	90	140	110	250	5 ⁺³ ₋₂	2LC0901-1EC	104
		>55 75		140									
565	2300	>75 100		170	630	425	100	165	130	280	5 ⁺³ ₋₂	2LC0901-2EC	135
		110		170									

Configurable variants¹⁾

- ØD1 Without finished bore
With finished bore
- Delivery without oil filling
Delivery with oil filling with specification of oil filling quantity in l
Delivery without oil filling with oil filling quantity specification in l

Notes

- The specified coupling weights are effective for maximum bores without oil filling.
- Delivery with oil filling only above -20 °C

Ordering example

- Motor 250 kW, $P_{eff} = 180$ kW, $n_1 = 1470$ rpm
- FLUDEX FVM coupling size 565
- Hollow shaft: Bore ØD2 = 75H7 with keyway to DIN 6885/1 and retaining screw
- Part 9: Bore ØD2 = 95H7 with keyway to DIN 6885/1 and set screw
- with seal set NBR
- thermal control unit for temperature monitoring
- Delivery without oil filling without oil filling quantity specification

Article no.: 2LC0901-2EC99-0AA0-Z L1M+M1H+F03+F25

¹⁾ To identify complete item numbers specifying the available finish boring options and – if necessary – further order options, please use our configurators on flender.com.

➤ For online configuration on flender.com, click on the item no.

OIL FILLING QUANTITIES FOR FV SERIES

This assignment is valid for a maximum starting torque $T_{max} = 1.5 \cdot T_{eff}$ and mineral oils with a viscosity of VG 22/VG 32.

If other operating fluids are used, or with drive via the hollow shaft or $T_{max} \neq 2.0 \cdot T_{eff}$ or $T_{max} \neq 1.5 \cdot T_{eff}$, changed filling quantities must be observed!

Sizes 370, 490, 655 and 887											
P_{eff} kW	Speed in rpm										Size
	600	740	890	980	1180	1470	1770	2300	2950	3550	
	Oil filling quantity in l										
1.1	5.3										
2.2	6.7	5.5									
3	7.4	6.1	5								
4	8	6.6	5.6	5							
5.5	13.8	7.4	6.2	5.6							
7.5	15.2	8	6.8	6.2	5.1						
11	17.4	14.1	7.7	7.1	5.9						
15	18.5	15.6	13	7.7	6.5	5.2					
18	31.6	16.6	13.8	12.5	6.9	5.5					
22	33.2	17.7	14.8	13.4	7.3	5.9	4.8				
30	36.5	18.5	16.3	14.9	12.3	6.5	5.5				
37	39.9	32.4	17.5	15.9	13.3	7	5.9	4.2			
45	44	34	18.5	17	14.1	7.5	6.2	4.6			
55	44	36.2	31	18.1	15.1	12	6.7	5.1			
75	75.8	41.4	33.6	31.2	16.7	13.5	7.4	5.7	4.2		
90	80	44	35.4	32.7	17.7	14.3	11.6	6.1	4.5		
110	74.3	44	38.2	34.5	29.9	15.2	12.6	6.4	5	4.1	
132	89.2	74.6	41.6	36.7	31.3	16.2	13.5	6.9	5.4	4.2	
160	96.3	78.7	44	39.8	32.9	17.3	14.4	10.4	5.7	4.6	370
200	107	83.6	72.1	44	34.9	29.4	15.4	11.7	6.2	5.1	
250	107	89.5	76.3	44	37.9	31.1	16.7	12.8		5.5	
315		98.5	81.5	75.6	42.1	33	28.6	13.9			490
350		103.6	83.7	77.7	44	33.9	29.5	14.4			
400		107	86.9	80.5	68.4	35.3	30.4				
500			94.5	85.3	73.8	38.4	32.3				655
600			102.9	90.6	77.3	41.8	33.8				
750			107	99.6	81.9	67.8	36.2				
900				107	86	72.7					
1100					92.3	76.2					887
1300					99.3	79.8					
1600						84					

Sizes 425, 565 and 755										
P_{eff} kW	Speed in rpm								Size	
	600	740	890	980	1180	1470	1770	2300		2950
	Oil filling quantity in l									
2.2	8									
3	9.1									
4	9.9	8.1								
5.5	11.1	9								
7.5	12	9.9	8.3	7.4						
11	21.4	11.3	9.4	8.6						
15	23.7	12	10.4	9.5	7.8					
18	25.2	20.5	11.1	10.1	8.4					
22	27	21.9	11.7	10.8	9					
30	43.2	24.2	20.1	11.8	9.9	7.9				
37	45.7	26	21.7	19.5	10.7	8.6	6.7			
45	48.3	27.7	23.1	21	11.3	9.2	7.5			
55	51.2	28	24.6	22.5	18.3	9.7	8.1			
75	58	46.8	27.4	24.8	20.7	10.8	9	6.5		
90	63.7	49.2	28	26.5	22	11.4	9.5	7.1		
110		52.3	44.5	28	23.4	18.7	10.2	7.8		
132		56.3	46.9	43.3	24.9	19.9	10.9	8.4	6.1	
160		61.9	49.5	45.6	26.7	21.4	16.8	8.9	6.6	
200		65	53.2	48.6	41.7	23	18.9	9.6	7.3	425
250			58.6	51.9	44.2	24.7	20.6	14.7	8	
315			65	57	47.3	26.8	22.3	16.1	8.7	
350				60	48.6	40.3	23	16.8		
400				64.4	50.5	42.2	24	18.1		565
500					54.7	44.6	37.9	19.9		
600					59.5	47.1	40	21.2		
750						50	42.9			
900						53.2	45			755
1100							47.7			

TYPE FNO

with large delay chamber and connecting shaft

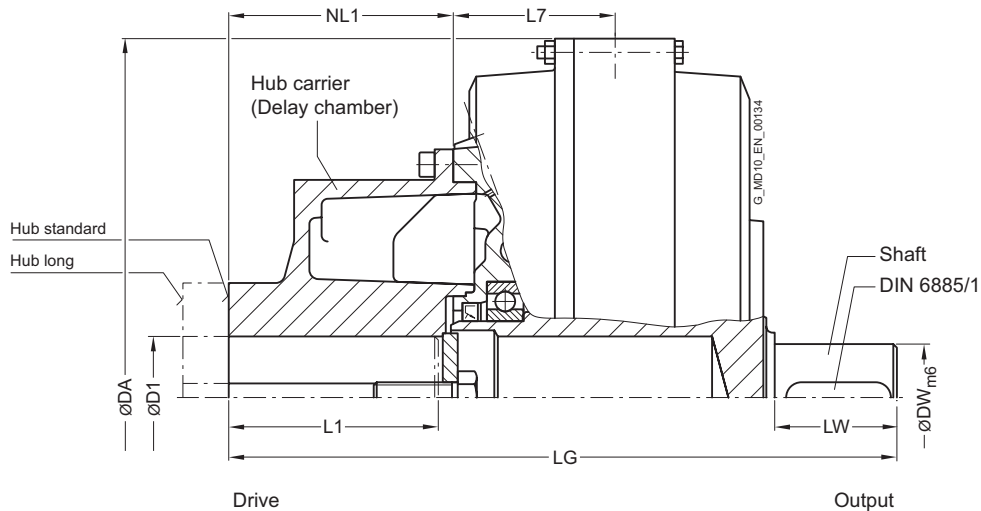

Size	Maximum speed n_{Kmax} rpm	Hub carrier Hub	Installation dimensions							Connection dimensions		Article no. ¹⁾	Weight m kg
			D1 Keyway DIN 6885 min. mm	max. mm	L1 max. mm	NL1 mm	DA mm	L7 mm	LG mm	DW mm	LW mm		
370	3600	Standard	38	55	110	115	420	101	380	60	70	2LC0900-8GA	56
		Long	38	80	140	145	420		410				
425	3000	Standard	42	75	140	147	470	106	437	70	80	2LC0901-0GA	77
		Long	42	100	170	177	470		467				
490	2600	Standard	48	75	140	148	555	131	485	70	90	2LC0901-1GA	116
		Long	48	110	170	178	555		515				
565	2300	Standard	65	95	170	178	630	131	543	90	100	2LC0901-2GA	158
		Long	65	120	210	218	630		583				
655	2000	Standard	65	110	210	218	736	156	644	100	125	2LC0901-3GA	240
		Long	65	135	250	258	736		684				
755	1800	Standard	65	120	210	219	840	170	705	110	140	2LC0901-4GA	321
		Long	65	150	250	259	840		745				
887	1500	Standard	65	150	250	251	990	187	835	120	178	2LC0901-5GA	562
		Long	65	170	300	301	990		885				

Configurable variants ¹⁾

- ØD1 Without finished bore
With finished bore
- Delivery without oil filling
Delivery with oil filling with specification of oil filling quantity in l
Delivery without oil filling with oil filling quantity specification in l

Notes

- The specified coupling weights are effective for maximum bores without oil filling.
- Delivery with oil filling only above -20 °C
- For mass moments of inertia, centroidal distance Y and weight FY, see Page 13/18.

Ordering example

- Motor 110 kW, $P_{eff} = 90$ kW, $n_1 = 1470$ rpm, maximum output torque $T_{max} = 1.3 \cdot T_{eff}$
- FLUDEX FNO coupling size 425
- Hub carrier: Standard hub bore ØD1 = 75H7 mm with keyway to DIN 6885/1 and retaining screw
- Seal set FPM
- Specification of oil filling quantity: 12.4 l (see Page 13/9)

Article no. with 160 °C fuse:

2LC0901-1GA90-1AA0-Z L1H+Y90+F08

Plain text to Y90: 12.4 l

¹⁾ To identify complete item numbers specifying the available finish boring options and – if necessary – further order options, please use our configurators on flender.com.

➤ For online configuration on flender.com, click on the item no.

TYPE FNA

with large delay chamber and N-EUPEX A add-on coupling

Enables a short fitting length.

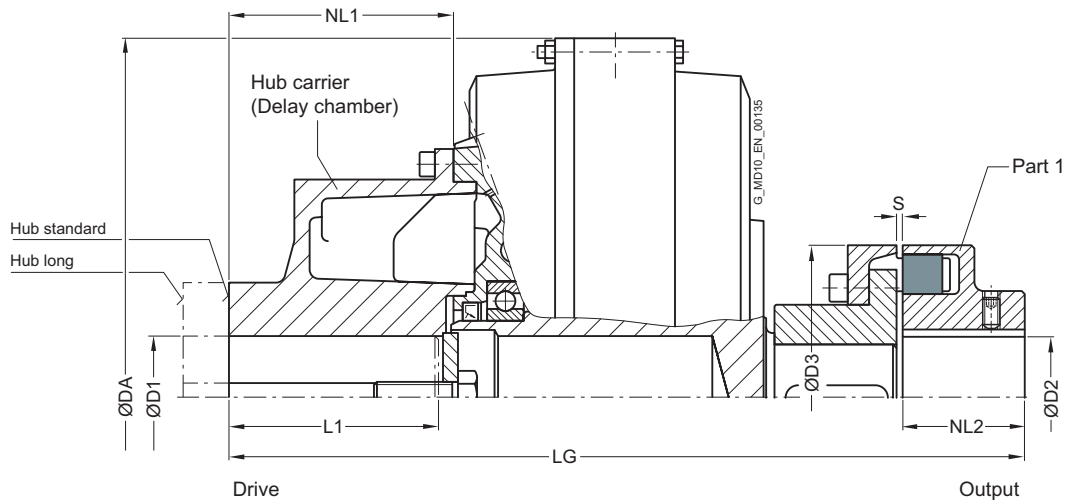

Size	Maximum speed n_{kmax} rpm	Hub carrier Hub	FLUDEX coupling						N-EUPEX A add-on coupling				Article no. ¹⁾	Weight <i>m</i> kg
			D1 Keyway DIN 6885 min. mm	max. mm	L1 max. mm	NL1 mm	DA mm	L6 mm	D2 max. mm	NL2 mm	Size D3 mm	S mm		
370	3600	Standard	38	55	110	115	420	454	75	70	180	4 ⁺² ₋₂	2LC0900-8GB	68
		Long	38	80	140	145	420	484					2LC0900-8GB	67
425	3000	Standard	42	75	140	147	470	521	85	80	200	4 ⁺² ₋₂	2LC0901-0GB	93
		Long	42	100	170	177	470	551					2LC0901-0GB	93
490	2600	Standard	48	75	140	148	555	579	90	90	225	4 ⁺² ₋₂	2LC0901-1GB	143
		Long	48	110	170	178	555	609					2LC0901-1GB	143
565	2300	Standard	65	95	170	178	630	648	100	100	250	5 ⁺³ ₋₂	2LC0901-2GB	193
		Long	65	120	210	218	630	688					2LC0901-2GB	195
655	2000	Standard	65	110	210	218	736	774	120	125	315	5 ⁺³ ₋₂	2LC0901-3GB	311
		Long	65	135	250	258	736	814					2LC0901-3GB	311
755	1800	Standard	65	120	210	219	840	850	140	140	350	5 ⁺³ ₋₂	2LC0901-4GB	420
		Long	65	150	250	259	840	890					2LC0901-4GB	417
887	1500	Standard	65	150	250	251	990	1023	160	180	440	8 ⁺² ₋₃	2LC0901-5GB	726
		Long	65	170	300	301	990	1073					2LC0901-5GB	727

Configurable variants¹⁾

- ØD1 Without finished bore
With finished bore
- ØD2 Without finished bore
With finished bore
- Delivery without oil filling
Delivery with oil filling with specification of oil filling quantity in l
Delivery without oil filling with oil filling quantity specification in l

Notes

- The specified coupling weights are effective for maximum bores without oil filling.
- Delivery with oil filling only above -20 °C
- For mass moments of inertia, centroidal distance Y and weight FY, see Page 13/18.

Ordering example

- Motor 750 kW, $P_{eff} = 600$ kW, $n_1 = 980$ rpm
- FLUDEX FNA coupling size 887
- Hub carrier: Standard hub bore ØD1 = 40H7 with keyway to DIN 6885/1 and retaining screw
- Part 1: Bore ØD2 = 120H7 with keyway to DIN 6885/1 and set screw
- with seal set FPM
- EOC system for temperature monitoring
- Delivery without oil filling with oil filling quantity specification

Article no. with EOC system:

2LC0901-5GB99-1AA0-Z L1V+M1S+F12+F26+Y90

Plain text Y90: 90.6 l

¹⁾ To identify complete item numbers specifying the available finish boring options and – if necessary – further order options, please use our configurators on flender.com.

➤ For online configuration on flender.com, click on the item no.

TYPE FND

with large delay chamber and N-EUPEX D add-on coupling

Enables fitting and dismantling of the coupling without displacement of the coupled shafts.

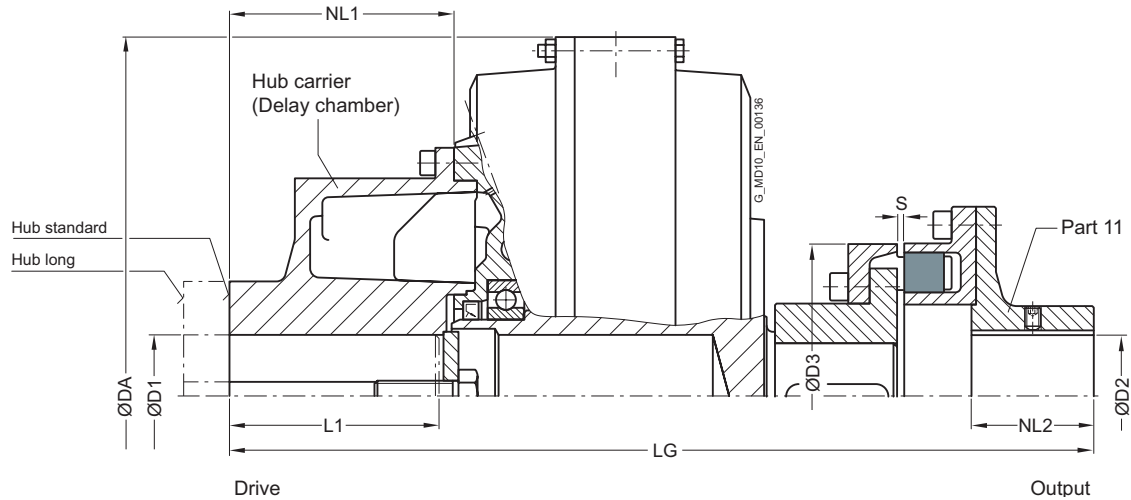

Size	Maximum speed n_{Kmax} rpm	Hub carrier Hub	FLUDEX coupling						N-EUPEX D coupling				Article no. ¹⁾	Weight <i>m</i> kg
			D1 Keyway DIN 6885 min. mm	max. mm	L1 max. mm	NL1 mm	DA mm	LG mm	D2 max. mm	NL2 mm	Size D3 mm	S mm		
370	3600	Standard	38	55	110	115	420	494	70	70	180	5 ⁺¹ ₋₁	2LC0900-8GC	72
		Long	38	80	140	145	420	524					2LC0900-8GC	71
425	3000	Standard	42	75	140	147	470	566	80	80	200	5 ⁺¹ ₋₁	2LC0901-0GC	99
		Long	42	100	170	177	470	596					2LC0901-0GC	99
490	2600	Standard	48	75	140	148	555	629	90	90	225	5 ⁺¹ ₋₁	2LC0901-1GC	150
		Long	48	110	170	178	555	659					2LC0901-1GC	150

Configurable variants ¹⁾

- ØD1 Without finished bore
With finished bore
- ØD2 Without finished bore
With finished bore
- Delivery without oil filling
Delivery with oil filling with specification of oil filling quantity in l
Delivery without oil filling with oil filling quantity specification in l

¹⁾ To identify complete item numbers specifying the available finish boring options and – if necessary – further order options, please use our configurators on flender.com.

↗ For online configuration on flender.com, click on the item no.

Size	Maximum speed n_{Kmax} rpm	Hub carrier Hub	FLUDEX coupling						N-EUPEX D coupling				Article no. ¹⁾	Weight <i>m</i> kg
			D1 Keyway DIN 6885		L1 max. mm	NL1 mm	DA mm	LG mm	D2 max. mm	NL2 mm	Size D3 mm	S mm		
			min. mm	max. mm										
565	2300	Standard	65	95	170	178	630	706	100	100	250	δ_{-1}^{+2}	2LC0901-2GC	204
		Long	65	120	210	218	630	746					2LC0901-2GC	206
655	2000	Standard	65	110	210	218	736	842	110	125	315	δ_{-1}^{+2}	2LC0901-3GC	324
		Long	65	135	250	258	736	882					2LC0901-3GC	324
755	1800	Standard	65	120	210	219	840	921	120	140	350	δ_{-1}^{+2}	2LC0901-4GC	440
		Long	65	150	250	259	840	961					2LC0901-4GC	437
887	1500	Standard	65	150	250	251	990	1104	130	180	440	δ_{-2}^{+2}	2LC0901-5GC	747
		Long	65	170	300	301	990	1154					2LC0901-5GC	748

Configurable variants ¹⁾

- $\varnothing D1$ Without finished bore
With finished bore
- $\varnothing D2$ Without finished bore
With finished bore
- Delivery without oil filling
Delivery with oil filling with specification of oil filling quantity in l
Delivery without oil filling with oil filling quantity specification in l

Notes

- The specified coupling weights are effective for maximum bores without oil filling.
- Delivery with oil filling only above -20 °C
- For mass moments of inertia, centroidal distance Y and weight FY, see **Page 13/18**.

Ordering example

- Motor 132 kW, $P_{eff} = 110$ kW, $n_1 = 1470$ rpm
- FLUDEX FND coupling size 490
- Hub carrier: Long hub bore $\varnothing D1 = 80H7$ mm with keyway to DIN 6885/1 and set screw
- Part 11: Bore $\varnothing D1 = 80H7$ mm with keyway to DIN 6885/1 and set screw
- with electronic or mechanical operation monitoring
- seal set NBR
- Delivery without oil filling, no oil filling quantity specification

Article no, with 110 °C thermal switch:

2LC0901-1GC99-2AA0-Z L1J+M1J+F03

Article no. with 125 °C EOC transmitter:

2LC0901-1GC99-2AA0-Z L1J+M1J+F04

¹⁾ To identify complete item numbers specifying the available finish boring options and – if necessary – further order options, please use our configurators on [flender.com](https://www.flender.com).

➤ For online configuration on [flender.com](https://www.flender.com), click on the item no.

TYPE FNDB

with large delay chamber, N-EUPEX A add-on coupling and brake drum

Enables fitting and dismantling of the coupling without displacement of the coupled shafts.

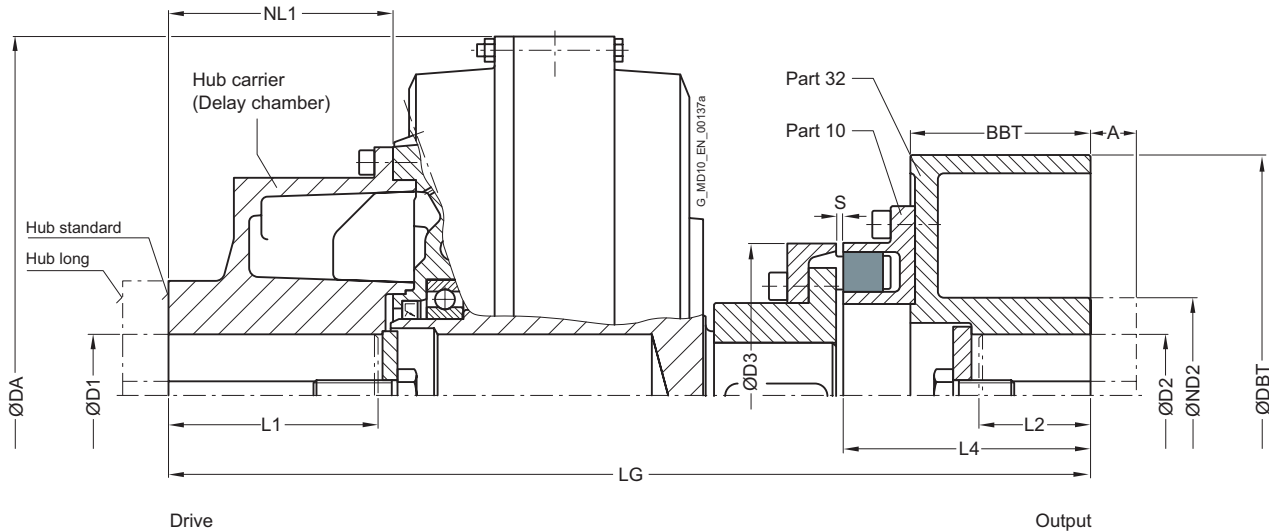

Size	Maximum speed n_{Kmax} rpm	Hub carrier Hub	FLUDEX coupling						N-EUPEX D add-on coupling			Brake drum (Part 32)					Article no. ¹⁾	Weight m kg
			D1 Keyway DIN 6885 min. mm	max. mm	L1 max. mm	NL1 mm	DA mm	LG mm	Size D3 mm	S mm	L4 mm	D2 max. mm	ND2 mm	DBT mm	BBT mm	A mm		
370	3000	Standard	38	55	110	115	420	542	180	5 ⁺¹ ₋₁	157	80	128	315	118	50	2LC0900-8GD	87
		Long	38	80	140	145	420	572				90	160	400	150	80	2LC0900-8GD	86
	2300	Standard	38	55	110	115	420	574			189	90	160	400	150	80	2LC0900-8GD	110
		Long	38	80	140	145	420	604					162	80	128	315	118	50
425	3000	Standard	42	75	140	147	470	604	200	5 ⁺¹ ₋₁	162	80	128	315	118	50	2LC0901-0GD	113
		Long	42	100	170	177	470	634				90	160	400	150	80	2LC0901-0GD	113
	2300	Standard	42	75	140	147	470	636			194	90	160	400	150	80	2LC0901-0GD	137
		Long	42	100	170	177	470	666					194	90	160	400	150	80

Configurable variants ¹⁾

- ØD1 Without finished bore
With finished bore

- ØD2 Without finished bore
With finished bore

- Part 32 Small brake drum
Large brake drum

- Delivery without oil filling
Delivery with oil filling with specification of oil filling quantity in l
Delivery without oil filling with oil filling quantity specification in l

¹⁾ To identify complete item numbers specifying the available finish boring options and – if necessary – further order options, please use our configurators on flender.com.

↗ For online configuration on flender.com, click on the item no.

Size	Maximum speed n_{Kmax} rpm	Hub carrier Hub	FLUDEX coupling						N-EUPEX D add-on coupling			Brake drum (Part 32)					Article no. ¹⁾	Weight <i>m</i> kg		
			D1 Keyway DIN 6885		L1	NL1	DA	LG	Size D3	S	L4	D2	ND2	DBT	BBT	A				
			min. mm	max. mm	max. mm	mm	mm	mm	mm	mm	mm	max. mm	mm	mm	mm	mm			mm	
490	2300	Standard	48	75	140	148	555	689	225	5 ⁺¹ ₋₁	199	90	160	400	150	80	2LC0901-1GD	183		
		Long	48	110	170	178	555	719				110	175	500	190	110	2LC0901-1GD	183		
	1900	Standard	48	75	140	148	555	729			239	110	175	500	190	110	2LC0901-1GD	218		
		Long	48	110	170	178	555	759									2LC0901-1GD	218		
565	2300	Standard	65	95	170	178	630	756	250	6 ⁺² ₋₁	207	100	160	400	150	80	2LC0901-2GD	234		
		Long	65	120	210	218	630	796				110	175	500	190	110	2LC0901-2GD	236		
	1900	Standard	65	95	170	178	630	796			247	110	175	500	190	110	2LC0901-2GD	268		
		Long	65	120	210	218	630	836									2LC0901-2GD	270		
655	1900	Standard	65	110	210	218	736	907	315	6 ⁺² ₋₁	257	110	175	500	190	110	2LC0901-3GD	377		
		Long	65	135	250	258	736	947				140	224	630	236	100	2LC0901-3GD	377		
	1500 ²⁾	Standard	65	110	210	218	736	953			303	140	224	630	236	100	2LC0901-3GD	437		
		Long	65	135	250	258	736	993									2LC0901-3GD	437		
755	1500 ²⁾	Standard	65	120	210	219	840	1018	350	6 ⁺² ₋₁	307	140	224	630	236	100	2LC0901-4GD	541		
		Long	65	150	250	259	840	1058				160	265	710	265	100	2LC0901-4GD	538		
887	1300 ³⁾	Standard	65	150	250	251	990	1190			440	8 ⁺² ₋₂	347	160	265	710	265	100	2LC0901-5GD	892
		Long	65	170	300	301	990	1240											2LC0901-5GD	893

Configurable variants ¹⁾

- ØD1 Without finished bore
With finished bore
- ØD2 Without finished bore
With finished bore
- Part 32 Small brake drum
Large brake drum
- Delivery without oil filling
Delivery with oil filling with specification of oil filling quantity in l
Delivery without oil filling with oil filling quantity specification in l

Notes

- The specified coupling weights are effective for maximum bores without oil filling, without hub prolongations "A" but with set screw
- L2 denotes the shaft insertion depth.
In the case of shaft ends deviating from DIN 748/1 long, the insertion depth must be specified in plain text with "Y29"
- Delivery with oil filling only above -20 °C
- For mass moments of inertia, centroidal distance Y and weight FY, see Page 13/18.

Ordering example:

- Motor 55 kW, $P_{eff} = 45$ kW, $n_1 = 1470$ rpm
- FLUDEX FNDB coupling size 370, standard type
- Hub carrier: Long hub bore ØD1 = 65H7 mm with keyway to DIN 6885/1 and set screw
- Brake drum (Part 32): Ø315 x 118, bore ØD2 = 80H7 mm with keyway to DIN 6885/1 and retaining screw
- seal set NBR
- Delivery without oil filling, no oil filling quantity specification

Article no.: 2LC0900-8GD99-2AA0-Z L1F+M1J

¹⁾ To identify complete item numbers specifying the available finish boring options and – if necessary – further order options, please use our configurators on flender.com.

²⁾ When performing a GGG brake drum: Maximum speed 1800 min⁻¹ possible.

³⁾ When performing a GGG brake drum: Maximum speed 1500 min⁻¹ possible.

➤ For online configuration on flender.com, click on the item no.

TYPE FNDS SB

with large delay chamber, N-EUPEX D add-on coupling and brake disk for stopping brakes

Enables fitting and dismantling of the coupling without displacement of the coupled shafts.

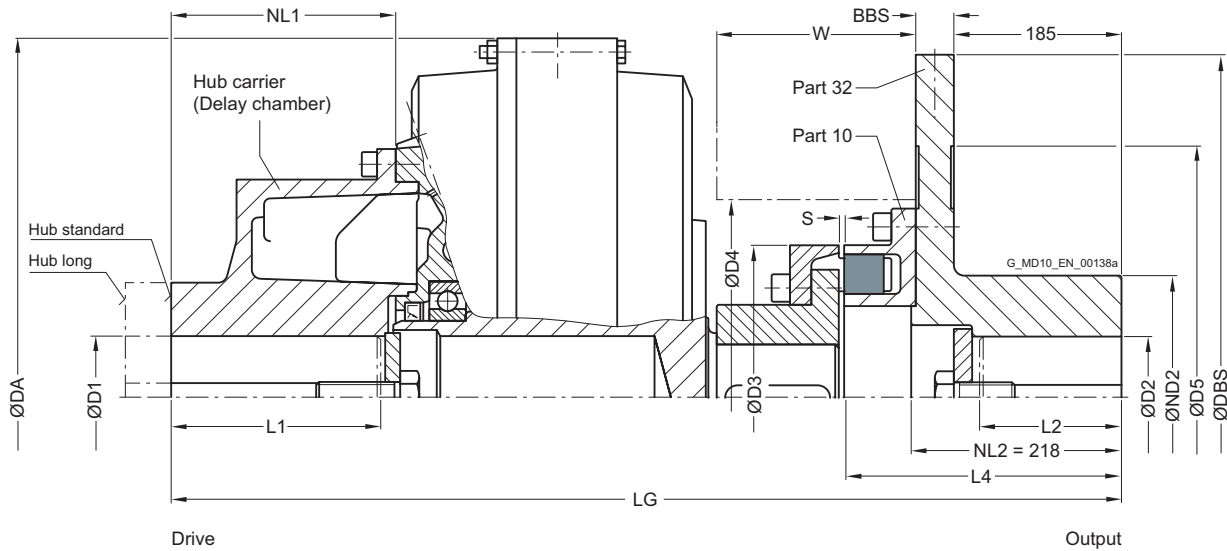

Size	Maximum speed n_{Kmax} rpm	Hub carrier Hub	FLUDEX coupling						N-EUPEX D add-on coupling			Brake disk (part 32) ²⁾					Space dimensions		Article no. ¹⁾	Weight <i>m</i> kg
			D1 Keyway DIN 6885 min. mm	max. mm	L1 max. mm	NL1 mm	DA mm	LG mm	Size D3	S	L4	D2 max. mm	ND2 mm	DBS mm	BBS mm	D5 mm	D4 mm	W mm		
370	3000	Standard	38	55	110	115	420	642	180	5 ⁺¹ ₋₁	257	80	145	450	30	300	222	130	2LC0900-8GE	116
		Long	38	80	140	145	420	672												
425	2600	Standard	42	75	140	147	470	704	200	5 ⁺¹ ₋₁	262	80	160	500	30	340	250	144	2LC0901-0GE	155
		Long	42	100	170	177	470	734												
490	2300	Standard	48	75	140	148	555	757	225	5 ⁺¹ ₋₁	267	90	160	560	30	370	276	162	2LC0901-1GE	212
		Long	48	110	170	178	555	787												

Configurable variants ¹⁾

- ØD1 Without finished bore
With finished bore
- ØD2 Without finished bore
With finished bore
- Delivery without oil filling
Delivery with oil filling with specification of oil filling quantity in l
Delivery without oil filling with oil filling quantity specification in l

¹⁾ To identify complete item numbers specifying the available finish boring options and – if necessary – further order options, please use our configurators on flender.com.

²⁾ Hub shortening possible, clearly specify NL2 size

↗ For online configuration on flender.com, click on the item no.

Size	Maximum speed n_{Kmax} rpm	Hub carrier Hub	FLUDEX coupling						N-EUPEX D add-on coupling			Brake disk (part 32) ²⁾					Space dimensions D4 W	Article no. ¹⁾	Weight <i>m</i> kg	
			D1 Keyway DIN 6885 min. mm	max. mm	L1 max. mm	NL1 mm	DA mm	LG mm	Size D3 mm	S mm	L4 mm	D2 max. mm	ND2 mm	DBS mm	BBS mm	D5 mm				
565	2100	Standard	65	95	170	178	630	824	250	6 ⁺² ₋₁	275	100	175	630	30	440	317	179	2LC0901-2GE	279
		Long	65	120	210	218	630	864												2LC0901-2GE
655	2000	Standard	65	110	210	218	736	935	315	6 ⁺² ₋₁	285	100	175	630	30	440	385	200	2LC0901-3GE	388
		Long	65	135	250	258	736	975												2LC0901-3GE
755	1800	Standard	65	120	210	219	840	1000	350	6 ⁺² ₋₁	289	140	220	710	30	520	435	219	2LC0901-4GE	518
		Long	65	150	250	259	840	1040												2LC0901-4GE
887	1500	Standard	65	150	250	251	990	1144	440	8 ⁺² ₋₂	301	140	220	800	30	610	525	268	2LC0901-5GE	828
		Long	65	170	300	301	990	1194												2LC0901-5GE

Configurable variants¹⁾

- ØD1 Without finished bore
With finished bore
- ØD2 Without finished bore
With finished bore
- Delivery without oil filling
Delivery with oil filling with specification of oil filling quantity in l
Delivery without oil filling with oil filling quantity specification in l

Notes

- The specified coupling weights are effective for maximum bores without oil filling.
- L2 denotes the shaft insertion depth
In the case of shaft ends deviating from DIN 748/1 long the insertion depth must be specified in plain text and with "Y29"
- Delivery with oil filling only above -20 °C
- For mass moments of inertia, centroidal distance Y and weight FY, see Page 13/18.

Ordering example

- Motor 37 kW, $P_{eff} = 30$ kW, $n_1 = 1470$ rpm
- FLUDEX FNDS SB coupling size 370
- Hub carrier: Standard hub bore ØD1 = 55H7 mm with keyway to DIN 6885/1 and retaining screw
- Brake disk (part 32): Bore ØD2 = 75H7 mm with keyway to DIN 6885/1 and retaining screw
- with preservation suitable for indoor storage
- Delivery without oil filling, no oil filling quantity specification

Article no. with standard preservation:
2LC0900-8GE99-1CA0-Z L1D+M1H

Article no. with preservation 6 months:
2LC0900-8GE99-1CA0-Z L1D+M1H+B31

Article no. with preservation 24 months:
2LC0900-8GE99-1CA0-Z L1D+M1H+B28

Article no. with preservation 36 months:
2LC0900-8GE99-1CA0-Z L1D+M1H+B34

¹⁾ To identify complete item numbers specifying the available finish boring options and – if necessary – further order options, please use our configurators on flender.com.

²⁾ Hub shortening possible, clearly specify NL2 size

↗ For online configuration on flender.com, click on the item no.

TYPE FNDS HB

with large delay chamber, N-EUPEX D add-on coupling and brake disk for blocking brakes

Enables fitting and dismantling of the coupling without displacement of the coupled shafts.

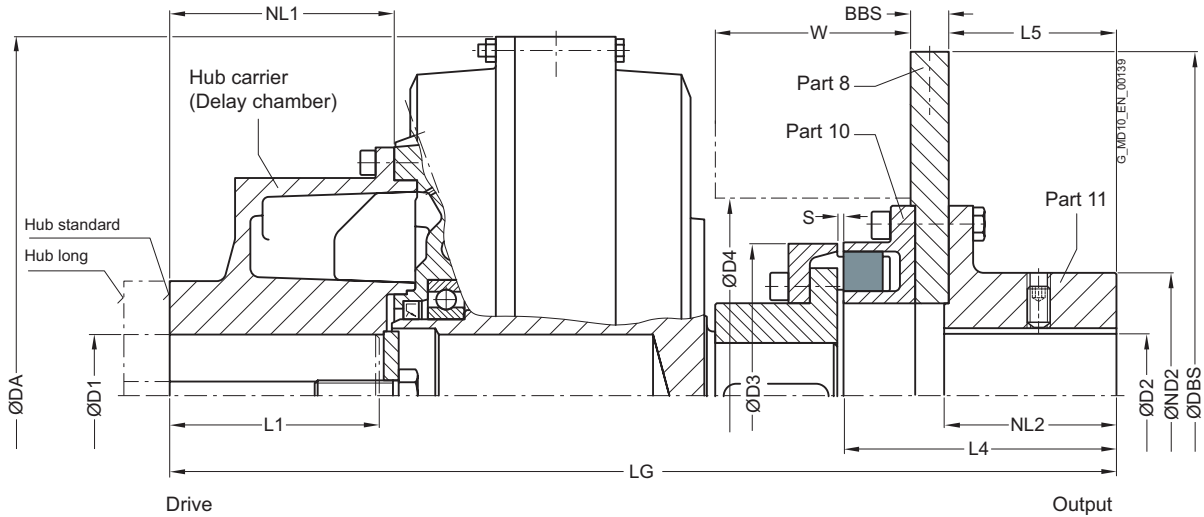

Size	Maximum speed n_{Kmax} rpm	Hub carrier Hub	FLUDEX coupling						N-EUPEX D add-on coupling			Brake disk (part 8) Hub (part 11)					Space dimensions		Article no. ¹⁾	Weight <i>m</i> kg	
			D1 Keyway DIN 6885 min. mm	D1 Keyway DIN 6885 max. mm	L1	NL1	DA	LG	Size D3	S	L4	D2 max. mm	NL2	ND2	DBS	BBS	D5 ²⁾	D4			W
370	3600	Standard	38	55	110	115	420	555	180	5 ⁺¹ ₋₁	170	80	118	130	355	16	115	222	127	2LC0900-8GF	87
		Long	38	80	140	145	420	585													
425	3000	Standard	42	75	140	147	470	617	200	5 ⁺¹ ₋₁	175	80	118	130	355	16	115	250	141	2LC0901-0GF	115
		Long	42	100	170	177	470	647													
490	2600	Standard	48	75	140	148	555	670	225	5 ⁺¹ ₋₁	180	85	118	135	400	16	115	276	159	2LC0901-1GF	166
		Long	48	110	170	178	555	700													

Configurable variants ¹⁾

- ØD1 Without finished bore
With finished bore
- ØD2 Without finished bore
With finished bore
- Delivery without oil filling
Delivery with oil filling with specification of oil filling quantity in l
Delivery without oil filling with oil filling quantity specification in l

¹⁾ To identify complete item numbers specifying the available finish boring options and – if necessary – further order options, please use our configurators on flender.com.

²⁾ Hub shortening possible, clearly specify L5 size

↗ For online configuration on flender.com, click on the item no.

Size	Maximum speed n_{Kmax} rpm	Hub carrier Hub	FLUDEX coupling						N-EUPEX D add-on coupling			Brake disk (part 8) Hub (part 11)					Space dimensions		Article no. ¹⁾	Weight m kg	
			D1 Keyway DIN 6885	L1	NL1	DA	LG	Size D3	S	L4	D2	NL2	ND2	DBS	BBS	D5 ²⁾	D4	W			
																					min. mm
565	2300	Standard	65	95	170	178	630	737	250	6 ⁺² ₋₁	188	100	118	160	450	16	115	317	176	2LC0901-2GF	224
		Long	65	120	210	218	630	777												2LC0901-2GF	226
655	2000	Standard	65	110	210	218	736	848	315	6 ⁺² ₋₁	198	100	118	170	500	16	115	385	197	2LC0901-3GF	347
		Long	65	135	250	258	736	888												2LC0901-3GF	347
755	1800	Standard	65	120	210	219	840	961	350	6 ⁺² ₋₁	250	140	164	225	630	20	160	435	215	2LC0901-4GF	495
		Long	65	150	250	259	840	1001												2LC0901-4GF	492
887	1500	Standard	65	150	250	251	990	1105	440	8 ⁺² ₋₂	262	140	164	225	710	20	160	525	264	2LC0901-5GF	799
		Long	65	170	300	301	990	1155												2LC0901-5GF	800

Configurable variants ¹⁾

- ØD1 Without finished bore
With finished bore
- ØD2 Without finished bore
With finished bore
- Delivery without oil filling
Delivery with oil filling with specification of oil filling quantity in l
Delivery without oil filling with oil filling quantity specification in l

Notes

- The specified coupling weights are effective for maximum bores without oil filling.
- L2 denotes the shaft insertion depth
In the case of shaft ends deviating from DIN 748/1 long the insertion depth must be specified in plain text and with "Y29"
- Delivery with oil filling only above -20 °C
- For mass moments of inertia, centroidal distance Y and weight FY, see Page 13/18.

Ordering example

- Motor 200 kW, $P_{eff} = 160$ kW, $n_1 = 1470$ rpm
- FLUDEX FNDS HB coupling size 490
- Hub carrier: Long hub bore ØD1 = 110H7 mm with keyway to DIN 6885/1 and set screw
- Hub (part 11): Bore ØD2 = 80H7 mm with keyway to DIN 6885/1 and set screw
- Fitting position: Horizontal/vertical motor underneath (MU)
- Delivery without oil filling, no oil filling quantity specification

Article no. in horizontal version:
2LC0901-1GF99-2AA0-Z L1Q+M1J

Article no. in vertical version (MU):
2LC0901-1GF99-2AA0-Z L1Q+M1J+F14

¹⁾ To identify complete item numbers specifying the available finish boring options and – if necessary – further order options, please use our configurators on flender.com.

²⁾ Hub shortening possible, clearly specify L5 size

↗ For online configuration on flender.com, click on the item no.

OIL FILLING QUANTITIES FOR FN SERIES

This assignment is valid for a maximum starting torque $T_{max} = 1.3 \cdot T_{eff}$ and mineral oils with a viscosity of VG 22/VG 32.

If other operating fluids are used, or with drive via the shaft or $T_{max} \neq 1.3 \cdot T_{eff}$, changed filling quantities must be observed!

Sizes 370, 490, 655 and 887											
P_{eff} kW	Speed in rpm										Size
	600	740	890	980	1180	1470	1770	2300	2950	3550	
Oil filling quantity in l											
1.1	5.6										
2.2	7.1	5.7									
3	7.9	6.4	5.1								
4	8.2	7	5.8	5.1							
5.5	14.4	7.8	6.5	5.9							
7.5	16	8.2	7.2	6.5	5.3						
11	18.2	14.7	8.2	7.4	6.2						
15	19	16.3	13.4	8.2	6.8	5.4					
18	33.5	17.3	14.4	12.9	7.2	5.8					
22	35.4	18.6	15.4	13.9	7.8	6.2	4.9				
30	38.5	19	17	15.5	12.5	6.9	5.7				
37	41.6	34.3	18.4	16.6	13.7	7.4	6.1	4.4			
45	45	36.2	19	17.7	14.7	7.9	6.6	4.7			
55	45	38.2	32.9	19	15.8	12.2	7	5.3			
75	76.5	43	35.8	33.1	17.4	14	7.8	6	4.3		
90	80.5	45	37.6	34.8	18.7	14.9	11.7	6.4	4.6		
110	85.2	45	40.1	36.7	31.8	16	13.1	6.8	5.1		
132	89.5	74.7	43.3	38.6	33.2	16.9	14	7.2	5.6	4.3	
160	95.6	80	45	41.5	35	18.1	15	10.7	6	4.7	
200	105.5	84.5	71.5	45	37.1	31.1	16.2	11.8	6.5	5.2	370
250	110	89.7	76.9	45	39.7	33	17.4	13.2		5.8	
315		97.5	82.4	76.5	43.8	35.1	30.2	14.5			490
350		102.1	84.6	78.4	45	36.1	31.2	15			
400		108.9	87.6	81.2	68	37.4	32.3				
500			94.1	86.1	73.3	40.2	34.2				655
600			101.4	90.6	78.1	43.5	35.9				
750			110	98.5	82.9	66.9	38.2				
900				107.2	86.8	72.7					
1100					92.1	77.1					887
1300					98.2	80.4					
1600						84.9					

Sizes 425, 565 and 755										Size
P_{eff} kW	Speed in rpm								Oil filling quantity in l	
	600	740	890	980	1180	1470	1770	2300		2950
2.2	8.5									
3	9.7									
4	10.7	8.6								
5.5	12	9.7								
7.5	12.5	10.7	8.8	7.7						
11	22.6	12.2	10.2	9.2						
15	25.2	12.5	11.2	10.2	8.3					
18	26.6	21.4	12	10.8	8.9					
22	28.6	23.1	12.5	11.6	9.6					
30	44.1	25.7	21.1	12.5	10.7	8.5				
37	46.8	27.5	22.9	20.5	11.4	9.2	7.1			
45	49.5	29	24.5	22	12.3	9.8	7.8			
55	52.4	29	26.1	23.7	18.7	10.5	8.6			
75	58.5	47.8	29	26.3	21.7	11.6	9.7	6.9		
90	63.8	50.5	29	27.9	23.2	12.4	10.3	7.4		
110		53.5	45.6	29	24.9	19	11	8.3		
132		57	47.9	44.3	26.3	20.9	11.7	8.9	6.6	
160		62	50.8	46.7	28.1	22.5	17.4	9.6	6.9	
200		67	54.2	49.9	42.1	24.3	19.5	10.3	7.6	425
250			59	53.1	45.3	26.2	21.6	16	8.6	
315			66.2	57.6	48.3	28.3	23.5	16.7	9.3	
350				60.3	49.9	40.8	24.4	17.4		
400				64.4	51.8	42.6	25.5	18.5		565
500					55.4	45.7	37.8	20.8		
600					59.8	48.1	40.6	22.3		
750						51.3	43.7			
900						54.2	46.1			755
1100							48.8			
1200							50.1			

SPARE AND WEAR PARTS

for standard catalog couplings

Flexible elements for N-EUPEX add-on coupling

FLUDEX coupling			N-EUPEX coupling	Number flexibles	Article No. (FFA)
Series	Size	Type	Size	per set	for one set flexibles
FA	222	FAK ¹⁾ ; FAKB ¹⁾	95	6	FFA:000001194870
		Other types	110	6	FFA:000001194871
	297	FAK ¹⁾ ; FAKB ¹⁾	125	6	FFA:000001194872
		FAK ²⁾ ; FAKB ²⁾	125	6	FFA:000001194873
		Other types	125	6	FFA:000001194873
	342	All types	140	6	FFA:000001194874
	395	FAD ¹⁾ ; FAE ¹⁾ ; FADB ¹⁾	225	8	FFA:000001194875
		FAD ²⁾ ; FAE ²⁾ ; FADB ²⁾	225	8	FFA:000001194876
		Other types	225	8	FFA:000001194876
	450	FAD ¹⁾ ; FAE ¹⁾ ; FADB ¹⁾	250	8	FFA:000001194877
		FAD ²⁾ ; FAE ²⁾ ; FADB ²⁾	250	8	FFA:000001194878
		Other types	250	8	FFA:000001194878
	516	FAD ¹⁾ ; FADB ¹⁾	315	9	FFA:000001194879
		FAD ²⁾ ; FADB ²⁾	315	9	FFA:000001194880
		Other types	315	9	FFA:000001194880
590	All types until 2010	315	9	FFA:000001194879	
	All types from 2011 on	315	9	FFA:000001194880	
FG/FV	370	All types	180	8	FFA:000001194881
	425		225	8	FFA:000001194876
	490		250	8	FFA:000001194878
	565		280	8	FFA:000001194882
	655		350	9	FFA:000001194883
	755		400	10	FFA:000001194884
	887		440	10	FFA:000001194885
FN	370	FNDB ØDBT = 400 ³⁾	200	8	FFA:000001194886
		All types	180	8	FFA:000001194881
	425	All types	200	8	FFA:000001194886
	490	FNDB ØDBT = 500 ³⁾	250	8	FFA:000001194878
		All types	225	8	FFA:000001194876
	565	All types	250	8	FFA:000001194878
	655		315	9	FFA:000001194880
	755		350	9	FFA:000001194883
887		440	10	FFA:000001194885	

¹⁾ For couplings up to and including year of construction 2003.

²⁾ For couplings from year of construction 2004.

³⁾ For couplings up to and including year of construction 2007.

Thermal equipment

FLUDEX size	Thread	Part no.	Fuse element	Response temperature	Marking	Article No. (FFA) for one unit
222	M10	103 + 104 ¹⁾	Fusible safety plug	110 °C	yellow	FFA:000001194896
		203 + 204 ¹⁾		140 °C	red	FFA:000001194897
				160 °C	green	FFA:000001194898
	M10	153 + 104 ¹⁾	Oil filler plug	-		FFA:000001194894
297	M10	153 + 104 ¹⁾	Oil filler plug	-		FFA:000001194894
297 - 887	M18 x 1.5	103 ²⁾	Fusible safety plug	110 °C	yellow	FFA:000001250338
		203 ²⁾		140 °C	red	FFA:000001250339
				160 °C	green	FFA:000001250380
	M18 x 1.5	110 ²⁾	Thermal switch	110 °C		FFA:000001361795
		210 ²⁾		140 °C		FFA:000001361796
	M18 x 1.5	153 ²⁾	Oil filler plug (except size 887)	-		FFA:000001337653
		163 ²⁾	Screw plug	-		
	-	301	Cut-out device	-		FFA:00000652020
	-	142 + 104 ¹⁾	EOC transmitter with seal	125 °C		FFA:000001194899
-	245	EOC sensor	-		FFA:000000361460	
-	244	Evaluation instrument EWD 20 to 250 V AC/DC	-		FFA:000001205294	
370 - 755	M10	173 + 174 ¹⁾	Oil drain plug - delay chamber	-		FFA:000001194894
887	M30 x 1.5	153 + 154 ¹⁾	Oil filler plug (up to and including year of construction 2007)	-		FFA:000001194893
		153 ²⁾	Oil filler plug (from year of construction 2008)	-		FFA:000001349554
	M16	173 + 174 ¹⁾	Oil drain plug - delay chamber	-		FFA:000001194895

Sealing and rolling bearing sets for the FA series (except type FAR)

FLUDEX size	Up to and including year of construction	From year of construction	Seal set material	Article No. (FFA) for one seal set	Article No. (FFA) for one rolling bearing set
222	2000	2001	NBR	FFA:000001194900	FFA:000001194800
			NBR	FFA:000001194901	FFA:000001194801
			FPM	FFA:000001194902	
297	2000	2001	NBR	FFA:000001194903	FFA:000001194802
			FPM	FFA:000001194904	
			NBR	FFA:000001194905	FFA:000001194803
342			FPM	FFA:000001194906	
			NBR	FFA:000001194907	FFA:000001194804
			FPM	FFA:000001194908	
395			NBR	FFA:000001194909	FFA:000001194805
			FPM	FFA:000001194910	
450			NBR	FFA:000001194911	FFA:000001194806
			FPM	FFA:000001194912	
516			NBR	FFA:000001194913	FFA:000001194807
			FPM	FFA:000001194914	
590			NBR	FFA:000001194915	FFA:000001194808
			FPM	FFA:000001194916	

¹⁾ With separate seal ring.

²⁾ With built-in ring seal.

SPARE AND WEAR PARTS

for standard catalog couplings

Seal and rolling bearing sets for type FAR ¹⁾

FLUDEX size	Type	Up to and including year of construction	From year of construction	Seal set material	Article No. [FFA] for one seal set	Article No. [FFA] for one rolling bearing set		
222	2 · SPZ 100		2000	NBR	FFA:000001194917	FFA:000001194809		
				NBR	FFA:000001194918	FFA:000001194810		
				FPM	FFA:000001194919			
3 · SPZ 160			2001	NBR	FFA:000001194920	FFA:000001194811		
				FPM	FFA:000001194921			
297	5 · SPZ 140	2000		NBR	FFA:000001194922	FFA:000001194812		
				FPM	FFA:000001194923			
	7 · SPZ 140	2000		NBR	FFA:000001194924	FFA:000001194813		
				FPM	FFA:000001194925			
	5 · SPZ 150			2001	NBR	FFA:000001194926		
					FPM	FFA:000001194927	FFA:000001194814	
4 · SPA 190				NBR	FFA:000001194928			
5 · SPA 224			2001	FPM	FFA:000001194929			
342	5 · SPA 180			NBR	FFA:000001194930	FFA:000001194815		
				FPM	FFA:000001194931			
	7 · SPA 180	2000			NBR	FFA:000001194932	FFA:000001194816	
				FPM	FFA:000001194933			
395	5 · SPB 224			NBR	FFA:000001194934	FFA:000001194817		
				FPM	FFA:000001194935			
	7 · SPB 224	2000			NBR	FFA:000001194936	FFA:000001194818	
					FPM	FFA:000001194937		
	7 · SPB 236			2001	NBR	FFA:000001194938		
				FPM	FFA:000001194939	FFA:000001194819		
450	8 · SPB 250	2000		NBR	FFA:000001194940	FFA:000001194820		
				($\varnothing D1 \leq 75$)		FPM	FFA:000001194941	
				$\varnothing D1 \leq 75$	2001	NBR	FFA:000001194942	FFA:000001194821
				2001	FPM	FFA:000001194943		
					NBR	FFA:000001194944	FFA:000001194822	
					FPM	FFA:000001194945		
10 · SPB 250	2000			NBR	FFA:000001194946	FFA:000001194823		
				FPM	FFA:000001194947			
516	10 · SPB 315	2000		NBR	FFA:000001194948	FFA:000001194824		
				FPM	FFA:000001194949			
				2001	NBR	FFA:000001194950	FFA:000001194825	
					FPM	FFA:000001194951		
12 · SPB 315	2000			NBR	FFA:000001194952	FFA:000001194826		
				FPM	FFA:000001194953			
590	12 · SPC 315	2000		NBR	FFA:000001194954	FFA:000001194827		
				FPM	FFA:000001194955			
				2001	NBR	FFA:000001194956	FFA:000001194828	
					FPM	FFA:000001194957		

¹⁾ Spare parts only suitable for specified belt pulleys.
Please request a different number of grooves by specifying the original delivery number.

Seal and rolling bearing sets for the FG/FV/FN series

FLUDEX coupling								
Series	Size	Year of construction	Additional bore specifications	Seal set material	Article No. (FFA) for one seal set	Article No. (FFA) for one rolling bearing set		
FG	370	Up to and including year of construction 2000		NBR	FFA:000001194958	FFA:000001194850		
				FPM	FFA:000001194959			
			From year of construction 2001		NBR	FFA:000001194958	FFA:000001194851	
					FPM	FFA:000001194959		
	425				NBR	FFA:000001194962	FFA:000001194852	
					FPM	FFA:000001194963		
	490				NBR	FFA:000001194966	FFA:000001194853	
					FPM	FFA:000001194967		
	565				NBR	FFA:000001194970	FFA:000001194854	
					FPM	FFA:000001194971		
	655			ØD2 ≤ 100		NBR	FFA:000001194974	FFA:000001194855
						FPM	FFA:000001194975	
				ØD2 > 100		NBR	FFA:000001194976	FFA:000001194856
						FPM	FFA:000001194977	
755			ØD2 ≤ 110		NBR	FFA:000001194982	FFA:000001194857	
					FPM	FFA:000001194983		
			ØD2 > 110		NBR	FFA:000001194984	FFA:000001194858	
					FPM	FFA:000001194985		
887				FPM	FFA:000001194993	FFA:000001194860		
FV	370	Up to and including year of construction 2000		NBR	FFA:000001194960	FFA:000001194850		
				FPM	FFA:000001194961			
			From year of construction 2001		NBR	FFA:000001194960	FFA:000001194851	
					FPM	FFA:000001194961		
	425				NBR	FFA:000001194964	FFA:000001194852	
					FPM	FFA:000001194965		
	490				NBR	FFA:000001194968	FFA:000001194853	
					FPM	FFA:000001194969		
	565				NBR	FFA:000001194972	FFA:000001194854	
					FPM	FFA:000001194973		
	655			ØD2 ≤ 100		NBR	FFA:000001194978	FFA:000001194855
						FPM	FFA:000001194979	
				ØD2 > 100		NBR	FFA:000001194980	FFA:000001194856
						FPM	FFA:000001194981	
755			ØD2 ≤ 110		NBR	FFA:000001194986	FFA:000001194857	
					FPM	FFA:000001194987		
			ØD2 > 110		NBR	FFA:000001194988	FFA:000001194858	
					FPM	FFA:000001194989		
887				FPM	FFA:000001194992	FFA:000001194860		
FN	370	Up to and including year of construction 2000		NBR	FFA:000001194960	FFA:000001194850		
				FPM	FFA:000001194961			
			From year of construction 2001		NBR	FFA:000001194960	FFA:000001194851	
					FPM	FFA:000001194961		
	425				NBR	FFA:000001194964	FFA:000001194852	
					FPM	FFA:000001194965		
	490				NBR	FFA:000001194968	FFA:000001194853	
					FPM	FFA:000001194969		
	565				NBR	FFA:000001194972	FFA:000001194854	
					FPM	FFA:000001194973		
	655				NBR	FFA:000001194978	FFA:000001194855	
					FPM	FFA:000001194979		
	755				NBR	FFA:000001194990	FFA:000001194859	
					FPM	FFA:000001194991		
887				FPM	FFA:000001194992	FFA:000001194860		

APPENDIX

Fits	A/2
Fitting recommendations	A/2
Deviation table to DIN ISO 286	A/2
Cylindrical shaft ends, extract from DIN 748 Part 1 (long)	A/3
Central holes according to DIN 332 Part 2	A/3

Parallel key connections to DIN 6885-1	A/4

Related catalogs	A/6

Suitable gear solutions	A/9

FITS

Fitting recommendations

For many applications, the fit assignment m6/H7 is especially suitable.

Description	Application	Shaft tolerance	Bore tolerance	
Sliding fit with parallel key connection not suitable for reversing operation	For steel and cast hubs	j6	H7	
		h6	J7	
Press fit with parallel key connection not suitable for reversing operation	For steel and cast hubs	h6	K7	
		k6	H7	
Interference fit with parallel key connection suitable for reversing operation	For steel and cast hubs	m6	H7	
		n6	H7	
		h6	M7	
		Only for steel hubs	h6	P7
		Preferred for ZAPEX and ARPEX coupling series.	k6	M7
		m6	K7	
		n6	J7	
		p6	H7	
Shrink fit connection without parallel key	Only for steel hubs The permitted hub tension must be urgently checked.	s6	F7	
		u6	H6	
		v6	H6	
		x6	H6	

Deviation table to DIN ISO 286 for above-mentioned fits for bore diameters from 10 mm to 250 mm

Bore diameter above	up to	Deviations in µm											
		Bore						Shaft					
		F7	H7	J7	K7	M7	P7	h6	j6	k6	m6	n6	p6
10	18	+34	+18	+10	+6	0	-11	0	+8	+12	+18	+23	+29
		+16	0	-8	-12	-18	-29	-11	-3	+1	+7	+12	+18
18	30	+41	+21	+12	+6	0	-14	0	+9	+15	+21	+28	+35
		+20	0	-9	-15	-21	-35	-13	-4	+2	+8	+15	+22
30	50	+50	+25	+14	+7	0	-17	0	+11	+18	+25	+33	+42
		+25	0	-11	-18	-25	-42	-16	-5	+2	+9	+17	+26
50	80	+60	+30	+18	+9	0	-21	0	+12	+21	+30	+39	+51
		+30	0	-12	-21	-30	-51	-19	-7	+2	+11	+20	+32
80	120	+71	+35	+22	+10	0	-24	0	+13	+25	+35	+45	+59
		+36	0	-13	-25	-35	-59	-22	-9	+3	+13	+23	+37
120	180	+83	+40	+26	+12	0	-28	0	+14	+28	+40	+52	+68
		+43	0	-14	-28	-40	-68	-25	-11	+3	+15	+27	+43
180	250	+96	+46	+30	+13	0	-33	0	+16	+33	+46	+60	+79
		+50	0	-16	-33	-46	-79	-29	-13	+4	+17	+31	+50

A

Cylindrical shaft ends, extract from DIN 748 Part 1 (long)

	Diameter in mm																					
	24	25	28	30	32	35	38	40	42	45	48	50	55	60	65	70	75	80	85	90	95	100
ISO tolerance zone	k6												m6									
End length in mm	50	60	80	110							140					170				210		

Central holes according to DIN 332 Part 2

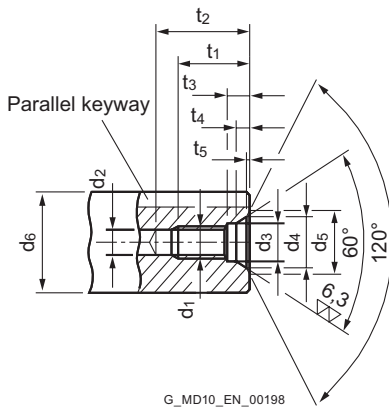

Form DS (with thread) DIN 332/2

Recommended diameter ranges d_6 ¹⁾		DS form dimensions									
above	up to	d_1	d_2 ²⁾	d_3	d_4	d_5	t_1 ₊₂	t_2 _{min.}	t_3 ₊₁	t_4 _{approx.}	t_5 _{approx.}
7	10	M3	2.5	3.2	5.3	5.8	9	12	2.6	1.8	0.2
10	13	M4	3.3	4.3	6.7	7.4	10	14	3.2	2.1	0.3
13	16	M5	4.2	5.3	8.1	8.8	12.5	17	4	2.4	0.3
16	21	M6	5	6.4	9.6	10.5	16	21	5	2.8	0.4
21	24	M8	6.8	8.4	12.2	13.2	19	25	6	3.3	0.4
24	30	M10	8.5	10.5	14.9	16.3	22	30	7.5	3.8	0.6
30	38	M12	10.2	13	18.1	19.8	28	37	9.5	4.4	0.7
38	50	M16	14	17	23	25.3	36	45	12	5.2	1.0
50	85	M20	17.5	21	28.4	31.3	42	53	15	6.4	1.3
85	130	M24	21	25	34.2	38	50	63	18	8	1.6
130	225	M30 ³⁾	26.5	31	40.2	44.6	60	77	22	8	1.9
225	320	M36 ³⁾	32	37	49.7	55	74	93	22	11	2.3
320	500	M42 ³⁾	37.5	43	60.3	66.6	84	105	26	15	2.7

¹⁾ Diameter refers to the finished workpiece

²⁾ Tap hole drill diameter according to DIN 336 Part 1

³⁾ Dimensions not acc. to DIN 332 Part 2

A

PARALLEL KEY CONNECTIONS TO DIN 6885-1

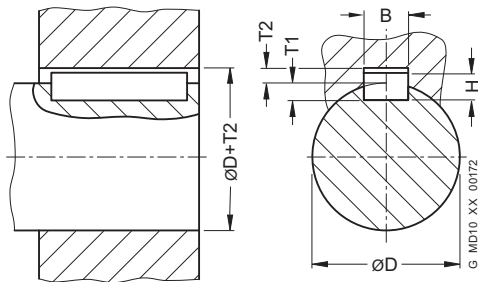

For moderate operating conditions, the hub keyway tolerance JS9 is recommended.

In harsh operating conditions or during reversing operation, the keyway width tolerance P9 must be preferred.

With two parallel keyways, the keyway width tolerance JS9 should be specified in order to simplify the assembly.

The shaft keyway width has to be specified with the tolerance N9.

Diameter above D mm	up to mm	Keyway width B mm	Parallel key height H mm	Shaft keyway depth T1 mm	Hub keyway depth T2 mm	Deviation for shaft and hub keyway depth mm	Deviation table for keyway width B	
							JS9 μm	P9 μm
	10	3	3	1.8	1.4	+0.1	+12.5 -12.5	-6 -31
10	12	4	4	2.5	1.8	+0.1	+15 -15	-12 -42
12	17	5	5	3	2.3	+0.1	+15 -15	-12 -42
17	22	6	6	3.5	2.8	+0.1	+15 -15	-12 -42
22	30	8	7	4	3.3	+0.2	+18 -18	-15 -51
30	38	10	8	5	3.3	+0.2	+18 -18	-15 -51
38	44	12	8	5	3.3	+0.2	+21.5 -21.5	-18 -61
44	50	14	9	5.5	3.8	+0.2	+21.5 -21.5	-18 -61
50	58	16	10	6	4.3	+0.2	+21.5 -21.5	-18 -61
58	65	18	11	7	4.4	+0.2	+21.5 -21.5	-18 -61
65	75	20	12	7.5	4.9	+0.2	+26 -26	-22 -74
75	85	22	14	9	5.4	+0.2	+26 -26	-22 -74
85	95	25	14	9	5.4	+0.2	+26 -26	-22 -74

Diameter		Keyway width B mm	Parallel key height H mm	Shaft keyway depth		Hub keyway depth T2 mm	Deviation for shaft and hub keyway depth mm	Deviation table for keyway width B	
above D mm	up to mm			T1 mm	T2 mm			JS9 µm	P9 µm
95	110	28	16	10	6.4	+0.2	+26	-22	
							-26	-74	
110	130	32	18	11	7.4	+0.2	+31	-26	
							-31	-88	
130	150	36	20	12	8.4	+0.3	+31	-26	
							-31	-88	
150	170	40	22	13	9.4	+0.3	+31	-26	
							-31	-88	
170	200	45	25	15	10.4	+0.3	+31	-26	
							-31	-88	
200	230	50	28	17	11.4	+0.3	+31	-26	
							-31	-88	
230	260	56	32	20	12.4	+0.3	+37	-32	
							-37	-106	
260	290	63	32	20	12.4	+0.3	+37	-32	
							-37	-106	
290	330	70	36	22	14.4	+0.3	+37	-32	
							-37	-106	
330	380	80	40	25	15.4	+0.3	+37	-32	
							-37	-106	
380	440	90	45	28	17.4	+0.3	+43.5	-37	
							-43.5	-124	
440	500	100	50	31	19.4	+0.3	+43.5	-37	
							-43.5	-124	



RELATED CATALOGS

Torsionally Rigid Couplings

FLE 10.1
FLEX-C10001-00-7600



ARPEX

High Performance Couplings
MD 10.2
PDMD-C10146-00



Flexible Couplings

FLE 10.2
FLEX-C10002-00-7600



SIPEX and BIPEX-S

Backlash-free couplings
MD 10.3
PDMD-C10145-00

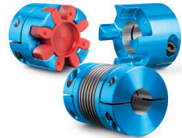

Highly Flexible Couplings

FLE 10.3
FLEX-C10003-00-7600



ARPEX

Composite Couplings
MD 10.5
PDMD-C10153-00

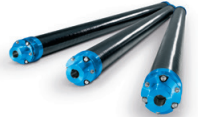

Fluid Couplings

FLE 10.4
FLEX-C10004-00-7600



ARPEX

Safety couplings
MD 10.11
PDMD-C10147-00



FLENDER SIP

Standard Industrial Planetary Gear Units

MD 31.1

PDMD-C10154-00

**FLENDER CHG**

Helical Gear Units

MD 20.10

PDMD-C10155-00

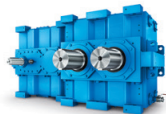
**Gear units**

Fast Track

MD 20.12

PDMD-C10156-00

**Bucket Elevator Drives**

MD 20.2

PDMD-C10157-00

**PLANUREX 2**

Planetary Gear Units

MD 20.3

PDMD-C10158-00

**Paper Machine Drives**

MD 20.5

PDMD-C10159-00

**Conveyor Belt Drives**

MD 20.6

PDMD-C10160-00

**Marine Reduction Gearboxes**

MD 20.7

PDMD-C10161-00

**DUORED 2**

Helical Gear Units, Load-sharing

MD 20.8

PDMD-C10162-00

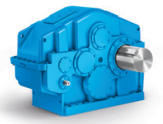
**Pinion Drive for Tube Mills**

MD 20.9

PDMD-C10163-00





THE RIGHT GEAR UNIT SOLUTION FOR ANY REQUIREMENT

We provide helical and planetary gear units made up of standard modules or as a complete application solution.

Helical and planetary gear units from Flender are modern drive solutions that satisfy the most varying and extreme demands, day after day and year after year. For decades, plant operators have been achieving high system reliability and low lifecycle costs in every conceivable industry with our helical gear units.

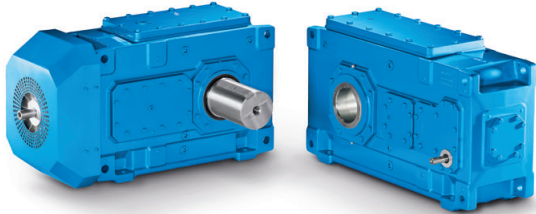

Helical and bevel helical gear units

Flender helical and bevel helical gear units are by far the most comprehensive range of industrial gear units in the world. It ranges from a multi-faceted universal gear unit portfolio and application-specific gear units to customer-specific solutions.

Rated torque: 3,300 Nm ... 1,400,000 Nm

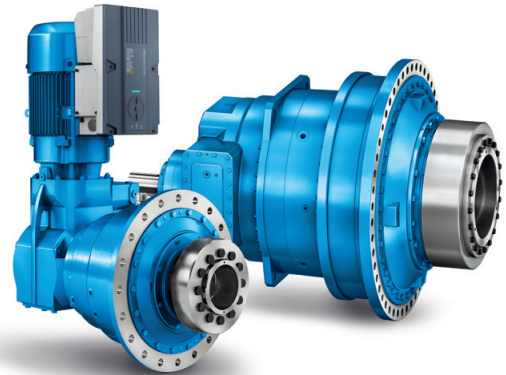

Planetary Gear Units

With Flender planetary gear units, we provide a range of durable, reliable and finely graduated gear unit solutions. The series wins customers over due to its highly integrated planetary geared motor and maximum conformity with all international motor standards. It also brings quality and performance in a good ratio of lifecycle costs to price.

Rated torque: 10,000 Nm ... 5,450,000 Nm

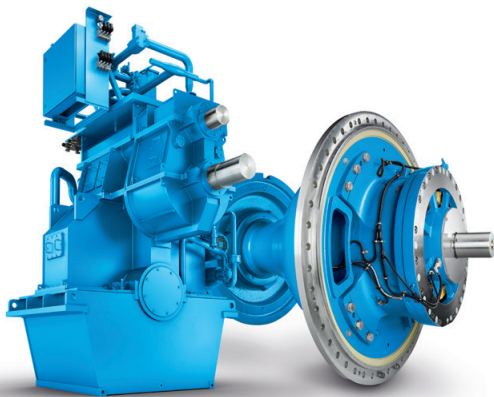

Application-specific gear units

With application-specific gear units, Flender provides by far the most application solutions and thus covers nearly every drive-related need from hundreds of applications in industry and the acquisition of raw materials.

Rated torque: up to 10,000,000 Nm



Customer-specific designs

Our experts are available at any time for special requirements during the development of new products. From designing and simulating complex drive solutions to implementing them, we work together with you to resolve multi-layered tasks.

FLENDER COUPLINGS CATALOG **FLE 10.4** EDITION 2020 EN

flender.com

Further information on the subject of couplings:

flender.com/couplings

Further information on the subject of applications:

flender.com/application-specific-gear-unit

For further information on gears:

flender.com/gearunits

Further information on the subject of service:

flender.com/services

Flender GmbH

Alfred-Flender-Straße 77

46395 Bocholt

Germany

Article no.: FLEX-C10004-00-7600

The information given in this product catalog includes descriptions and performance features that in specific applications do not always apply in the form described or may change through further-development of the products. The desired performance features are binding only if they are expressly agreed on conclusion of contract. Subject to availability for delivery and to technical changes.

flender.com