



S
N
S
N
E

METRIC CHAINS, ISO 1977
DIN 8167 (M series)



METRIC CHAINS, ISO 1977 – DIN 8167

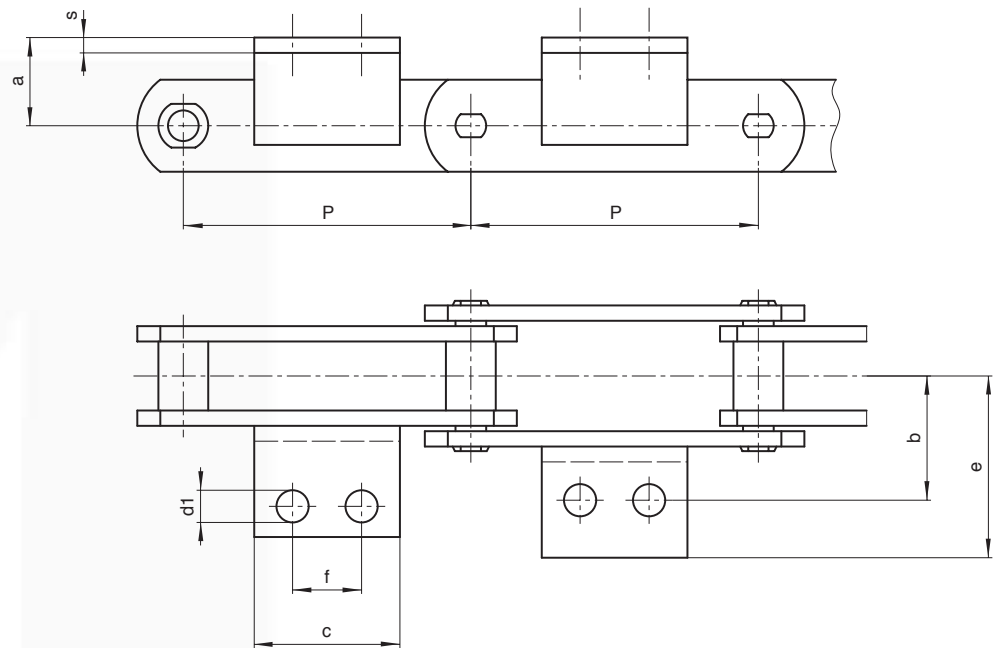

Layout of attachments
on page 1.9/2

ATTACHMENTS

Chain N.	P mm	a mm	b mm	c mm	d1 mm	e mm	f mm	Angle mm	Chain weight Kg/mt				Weight per attach. kg
									type A	type B	type C	type D	
M 20	40	16	27	14	6,6	40	●	⊗	1,1	1,3	2,4	2,5	0,020
"	50	"	"	14	"	"	●	⊗	1,01	1,3	2	2,1	0,020
"	63	"	"	35	"	"	20	25x3	0,99	1,2	1,8	1,9	0,040
"	80	"	"	50	"	"	35	"	0,9	1,1	1,6	1,6	0,060
M28	50	20	32	20	9	47	●	20x3	1,6	1,9	3,3	3,4	0,020
"	63	"	"	20	"	"	●	30x3	1,5	1,7	2,8	2,9	0,020
"	80	"	"	45	"	"	25	"	1,4	1,6	2,5	2,6	0,050
"	100	"	"	60	"	"	40	"	1,3	1,5	2,1	2,2	0,080
M 40	63	25	35	31	9	50	●	⊗ 30x4	2,25	2,6	4,4	4,6	0,040
"	80	"	"	45	"	"	20	⊗ "	2	2,3	3,7	3,9	0,070
"	100	"	"	60	"	"	40	⊗ "	1,9	2,1	3,2	3,4	0,100
"	125	"	"	85	"	"	65	"	1,8	2	2,9	3	0,150
M 56	63	30	44	22	11	61	●	40x4	3,4	3,9	6,8	7,2	0,050
"	80	"	"	30	"	"	●	"	3	3,4	5,7	6	0,070
"	100	"	"	50	"	"	25	"	2,8	3,1	5	5,2	0,120
"	125	"	"	75	"	"	50	"	2,6	2,9	4,4	4,5	0,180
"	160	"	"	110	"	"	85	"	2,54	2,7	3,9	4,1	0,270
M 80	80	35	48	30	11	65	●	⊗ 40x4	4,7	5,4	9,2	9,4	0,070
"	100	"	"	50	"	"	25	⊗ "	4,3	4,8	7,9	8	0,120
"	125	"	"	75	"	"	50	⊗ "	4	4,4	6,9	7	0,180
"	160	"	"	110	"	"	85	⊗ "	3,7	4	6	6,1	0,270
"	200	"	"	150	"	"	125	⊗ "	3,5	3,8	5,3	5,4	0,360

● attachments with 1 hole
⊗ as alternative integral attachments

All attachments can be with one hole



METRIC CHAINS, ISO 1977 – DIN 8167

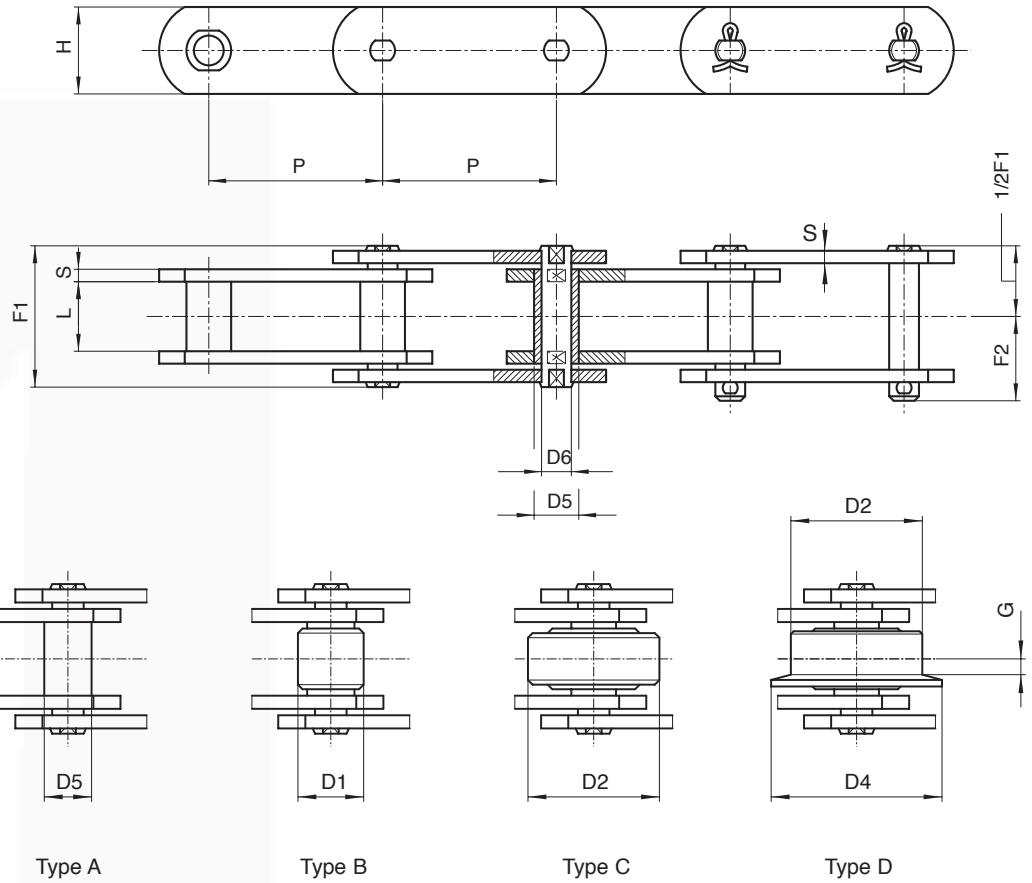

SOLID PIN CHAINS

Chain N.	P mm	L mm	D1 mm	D2 mm	D4 mm	G mm	D5 mm	D6 mm	H mm	S mm	F1 mm	F2 mm	Breaking load	
													N	N*
M 112	80	32	30	60	75	7,5	21	15	40	6	63	36	112.000	175.000
"	100	"	"	"	"	"	"	"	"	"	"	"	"	"
"	125	"	"	"	"	"	"	"	"	"	"	"	"	"
"	160	"	"	"	"	"	"	"	"	"	"	"	"	"
"	200	"	"	"	"	"	"	"	"	"	"	"	"	"
M 160	100	37	36	70	90	8,5	25	18	50	7	72	41,5	160.000	260.000
"	125	"	"	"	"	"	"	"	"	"	"	"	"	"
"	160	"	"	"	"	"	"	"	"	"	"	"	"	"
"	200	"	"	"	"	"	"	"	"	"	"	"	"	"
"	250	"	"	"	"	"	"	"	"	"	"	"	"	"
M 224	125	43	42	85	105	10	30	21	60	8	84	47	224.000	340.000
"	160	"	"	"	"	"	"	"	"	"	"	"	"	"
"	200	"	"	"	"	"	"	"	"	"	"	"	"	"
"	250	"	"	"	"	"	"	"	"	"	"	"	"	"
"	315	"	"	"	"	"	"	"	"	"	"	"	"	"
M 315	160	48	50	100	124	10,5	36	25	70	10	97	55	315.000	520.000
"	200	"	"	"	"	"	"	"	"	"	"	"	"	"
"	250	"	"	"	"	"	"	"	"	"	"	"	"	"
"	315	"	"	"	"	"	"	"	"	"	"	"	"	"
"	400	"	"	"	"	"	"	"	"	"	"	"	"	"

(*) Breaking load with heat treated plates

- Additional features:
- rollers of nylon, delrin, etc.
 - with extended pins
 - in STAINLESS steel
 - surface treatments of zinc plating, nickel plating, etc.
 - pre-tensioned and labelled



METRIC CHAINS, ISO 1977 – DIN 8167

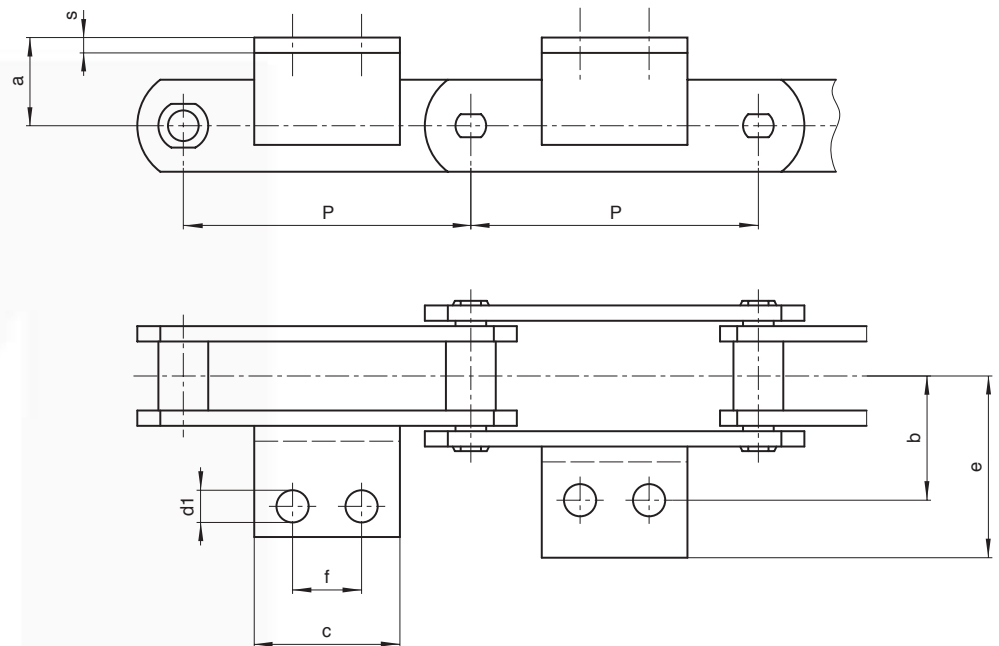

Layout of attachments
on page 1.9/2

ATTACHMENTS

Chain N.	P mm	a mm	b mm	c mm	d1 mm	e mm	f mm	Angle mm	Chain weight Kg/mt				Weight per attach. kg
									type A	type B	type C	type D	
M 112	80	40	55	28	14	80	●	50x6	6,8	8	14	14,7	0,130
"	100	"	"	40	"	"	●	"	6,2	7,2	12	12,5	0,180
"	125	"	"	65	"	"	35	"	5,7	6,5	10,4	10,8	0,300
"	160	"	"	95	"	"	65	"	5,3	5,9	9	9,3	0,440
"	200	"	"	130	"	"	100	"	5	5,5	7,9	8,2	0,590
M 160	100	45	62	30	14	85	●	50x6	9,7	11,2	18,9	20,2	0,130
"	125	"	"	50	"	"	25	"	8,9	10	16,3	18,1	0,230
"	160	"	"	80	"	"	50	"	8,2	9,1	14	15,4	0,370
"	200	"	"	115	"	"	85	"	7,6	8,4	12,2	13,4	0,530
"	250	"	"	175	"	"	145	"	7,3	7,9	11	12	0,800
M 224	125	55	70	35	18	100	●	60x8	13	14,8	25,8	26,6	0,300
"	160	"	"	60	"	"	●	"	12	13,4	22	22,7	0,430
"	200	"	"	100	"	"	65	"	11	12,1	19	19,5	0,710
"	250	"	"	160	"	"	125	"	10,3	11,2	16,7	17,1	1,130
"	315	"	"	230	"	"	190	"	9,8	10,5	14,9	15,2	1,600
M 315	160	65	80	35	18	115	●	70x9	18,3	20,4	33,3	34,6	0,320
"	200	"	"	85	"	"	50	"	16,7	18,4	28,7	29,7	0,660
"	250	"	"	140	"	"	100	"	15,6	17	25,2	26	1,100
"	315	"	"	190	"	"	155	"	14,6	15,7	22,3	22,9	1,460
"	400	"	"	205	"	"	155	"	13,9	14,8	20	20,5	1,460

● attachments with 1 hole
All attachments can be with one hole



METRIC CHAINS, ISO 1977 – DIN 8167

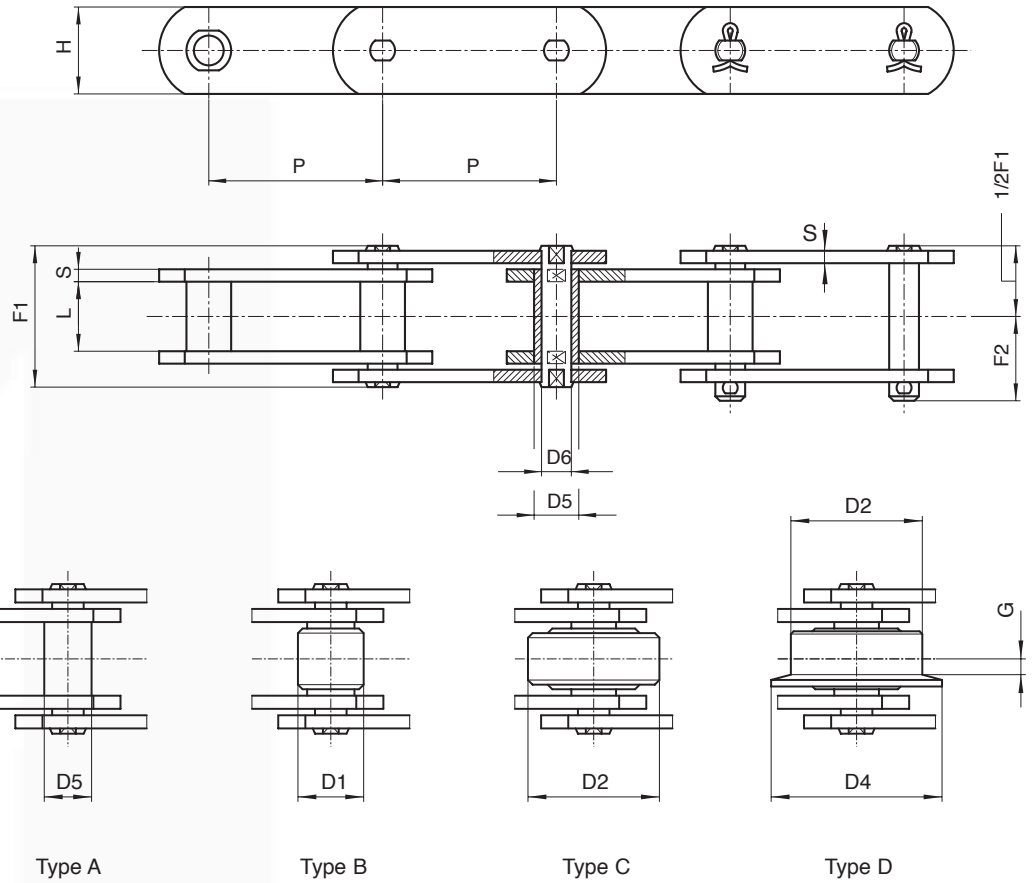

SOLID PIN CHAINS

Chain N.	P mm	L mm	D1 mm	D2 mm	D4 mm	G mm	D5 mm	D6 mm	H mm	S mm	F1 mm	F2 mm	Breaking load	
													N	N*
M 450	200	56	60	120	149	11,5	42	30	80	12	114	67	450.000	700.000
"	250	"	"	"	"	"	"	"	"	"	"	"	"	"
"	315	"	"	"	"	"	"	"	"	"	"	"	"	"
"	400	"	"	"	"	"	"	"	"	"	"	"	"	"
M 630	250	67	70	140	170	15	50	36	100	14	137	87,5	630.000	900.000
"	315	"	"	"	"	"	"	"	"	"	"	"	"	"
"	400	"	"	"	"	"	"	"	"	"	"	"	"	"
"	500	"	"	"	"	"	"	"	"	"	"	"	"	"
M 900	250	78	85	170	210	17	60	44	120	16	153	95	900.000	1.250.000
"	315	"	"	"	"	"	"	"	"	"	"	"	"	"
"	400	"	"	"	"	"	"	"	"	"	"	"	"	"
"	500	"	"	"	"	"	"	"	"	"	"	"	"	"
"	600	"	"	"	"	"	"	"	"	"	"	"	"	"

(*) Breaking load with heat treated plates

- Additional features:
- rollers of nylon, delrin, etc.
 - with extended pins
 - in STAINLESS steel
 - surface treatments of zinc plating, nickel plating, etc.
 - pre-tensioned and labelled



METRIC CHAINS, ISO 1977 – DIN 8167

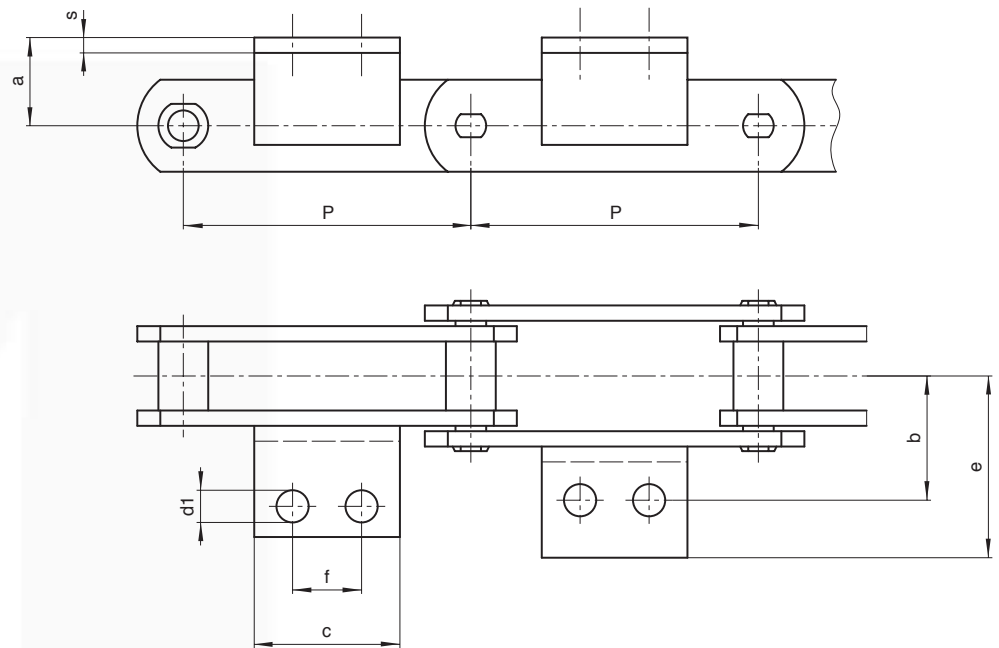

Layout of attachments
on page 1.9/2

ATTACHMENTS

Chain N.	P mm	a mm	b mm	c mm	d1 mm	e mm	f mm	Angle mm	Chain weight Kg/mt				Weight per attach. kg
									type A	type B	type C	type D	
M 450	200	75	90	40	18	125	●	70x9	24	27	40,5	47	0,330
"	250	"	"	125	"	"	85	"	22	24,9	39,5	41	1,000
"	315	"	"	195	"	"	155	"	21	23	34,5	36	1,600
"	400	"	"	280	"	"	240	"	19,6	21,2	30,5	31,4	2,300
M 630	250	90	115	50	24	165	●	100x12	36	40,8	64	66,9	0,900
"	315	"	"	150	"	"	100	"	33,4	36,6	55,5	57,7	2,700
"	400	"	"	240	"	"	190	"	31,5	33,9	49	50,7	4,300
"	500	"	"	350	"	"	300	"	29,6	31,6	43,6	45	6,200
M 900	250	110	140	60	30	195	●	120x15	49,7	56,5	98,3	104,5	1,600
"	315	"	"	125	"	"	65	"	45,5	51,8	84,2	89,7	3,300
"	400	"	"	215	"	"	155	"	42	46,2	72,5	76,9	5,700
"	500	"	"	300	"	"	240	"	39,3	42,7	63,8	67,6	8,000
"	600	"	"	350	"	"	300	"	37,3	39,9	56,6	58,9	8,000

● attachments with 1 hole
All attachments can be with one hole



METRIC CHAINS, ISO 1977 – DIN 8168

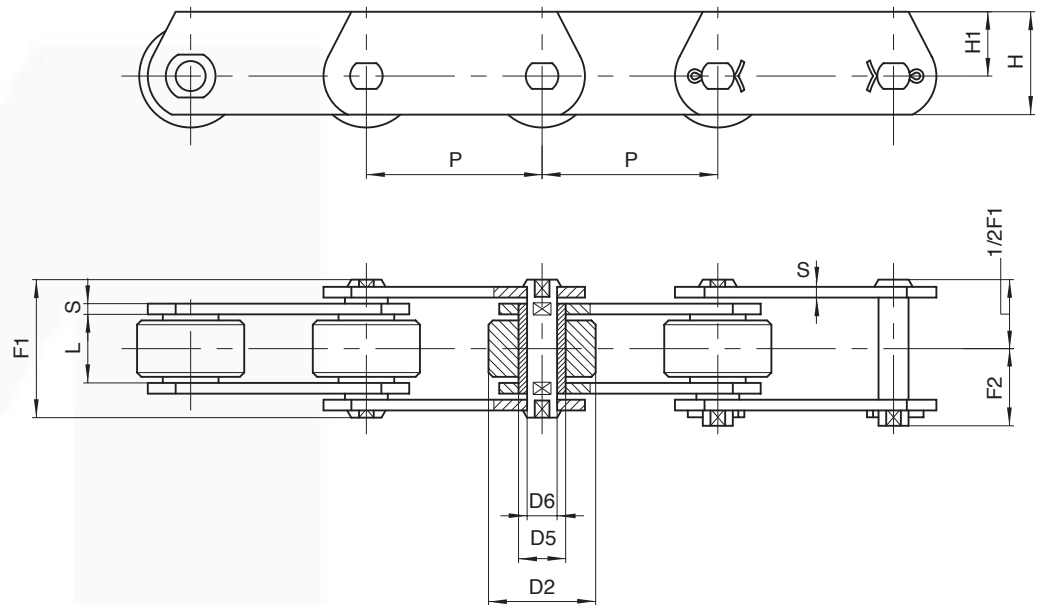

DEEP LINK CHAINS

Chain N.	P mm	L mm	D2 mm	D5 mm	D6 mm	H mm	H1 mm	S mm	F1 mm	F2 mm	Breaking load		Chain weight kg/m
											N	N*	
ME 20	40	16	25	9	6	25	16	2,5	33	19	20.000	32.000	3
"	50	"	"	"	"	"	"	"	"	"	"	"	2,6
"	63	"	"	"	"	"	"	"	"	"	"	"	2,3
"	80	"	"	"	"	"	"	"	"	"	"	"	2
ME 28	50	18	30	10	7	30	20	3	36	20,5	28.000	42.000	4,1
"	63	"	"	"	"	"	"	"	"	"	"	"	3,5
"	80	"	"	"	"	"	"	"	"	"	"	"	3,1
"	100	"	"	"	"	"	"	"	"	"	"	"	2,8
ME 40	63	20	36	11	8	35	22,5	4	40,5	24	40.000	60.000	5,5
"	80	"	"	"	"	"	"	"	"	"	"	"	4,8
"	100	"	"	"	"	"	"	"	"	"	"	"	4,2
"	125	"	"	"	"	"	"	"	"	"	"	"	3,7
ME 56	63	24	42	15	10	45	30	4	45	26	56.000	85.000	8,3
"	80	"	"	"	"	"	"	"	"	"	"	"	7
"	100	"	"	"	"	"	"	"	"	"	"	"	6,1
"	125	"	"	"	"	"	"	"	"	"	"	"	5,4
ME 80	80	28	50	18	12	50	32,5	5	54,5	30,5	80.000	125.000	11
"	100	"	"	"	"	"	"	"	"	"	"	"	9,5
"	125	"	"	"	"	"	"	"	"	"	"	"	8,5
"	160	"	"	"	"	"	"	"	"	"	"	"	7,2
"	200	"	"	"	"	"	"	"	"	"	"	"	6

(*) Breaking load with heat treated plates

Additional features:

- rollers of nylon, delrin, etc.
- in STAINLESS steel
- surface treatments of zinc plating, nickel plating, etc.
- pre-tensioned and labelled



METRIC CHAINS, ISO 1977 – DIN 8168

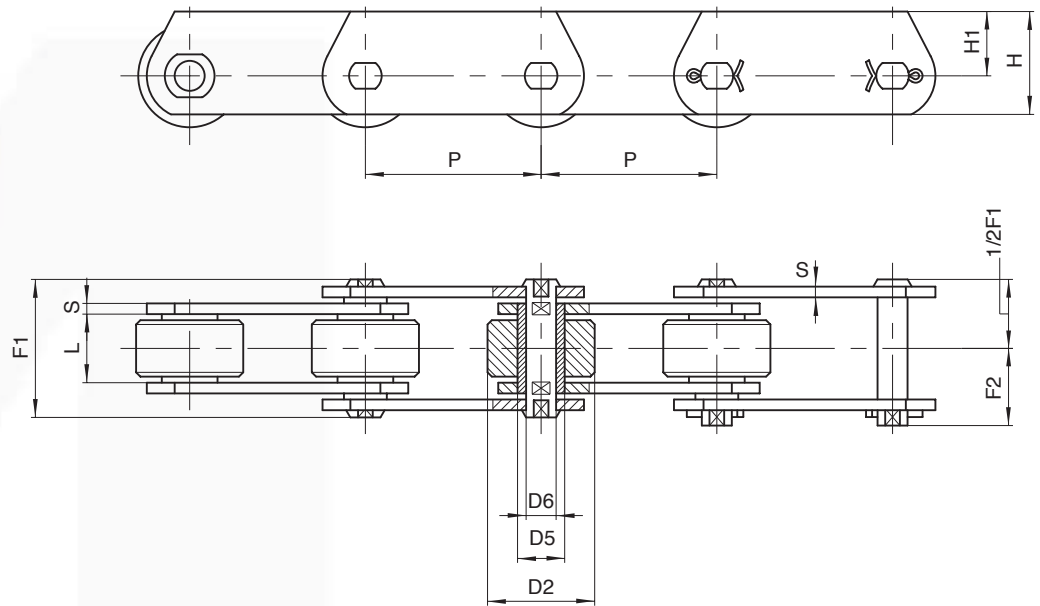

DEEP LINK CHAINS

Chain N.	P mm	L mm	D2 mm	D5 mm	D6 mm	H mm	H1 mm	S mm	F1 mm	F2 mm	Breaking load		Chain weight kg/m
											N	N*	
ME 112	80	32	60	21	15	60	40	6	63	36	112.000	175.000	17
"	100	"	"	"	"	"	"	"	"	"	"	"	14,5
"	125	"	"	"	"	"	"	"	"	"	"	"	13
"	160	"	"	"	"	"	"	"	"	"	"	"	11
"	200	"	"	"	"	"	"	"	"	"	"	"	10
ME 160	100	37	70	25	18	70	45	7	72	41,5	160.000	260.000	21,5
"	125	"	"	"	"	"	"	"	"	"	"	"	19
"	160	"	"	"	"	"	"	"	"	"	"	"	17
"	200	"	"	"	"	"	"	"	"	"	"	"	15
"	250	"	"	"	"	"	"	"	"	"	"	"	13,5
ME 224	125	43	85	30	21	90	60	8	84	47	224.000	340.000	32,5
"	160	"	"	"	"	"	"	"	"	"	"	"	27,5
"	200	"	"	"	"	"	"	"	"	"	"	"	23
"	250	"	"	"	"	"	"	"	"	"	"	"	21
"	315	"	"	"	"	"	"	"	"	"	"	"	19
ME 315	160	48	100	36	25	100	65	10	97	55	315.000	520.000	43
"	200	"	"	"	"	"	"	"	"	"	"	"	37
"	250	"	"	"	"	"	"	"	"	"	"	"	32
"	315	"	"	"	"	"	"	"	"	"	"	"	28,6
"	400	"	"	"	"	"	"	"	"	"	"	"	25,5

(*) Breaking load with heat treated plates

- Additional features:
- rollers of nylon, delrin, etc.
 - in STAINLESS steel
 - surface treatments of zinc plating, nickel plating, etc.
 - pre-tensioned and labelled



METRIC CHAINS, ISO 1977 – DIN 8168

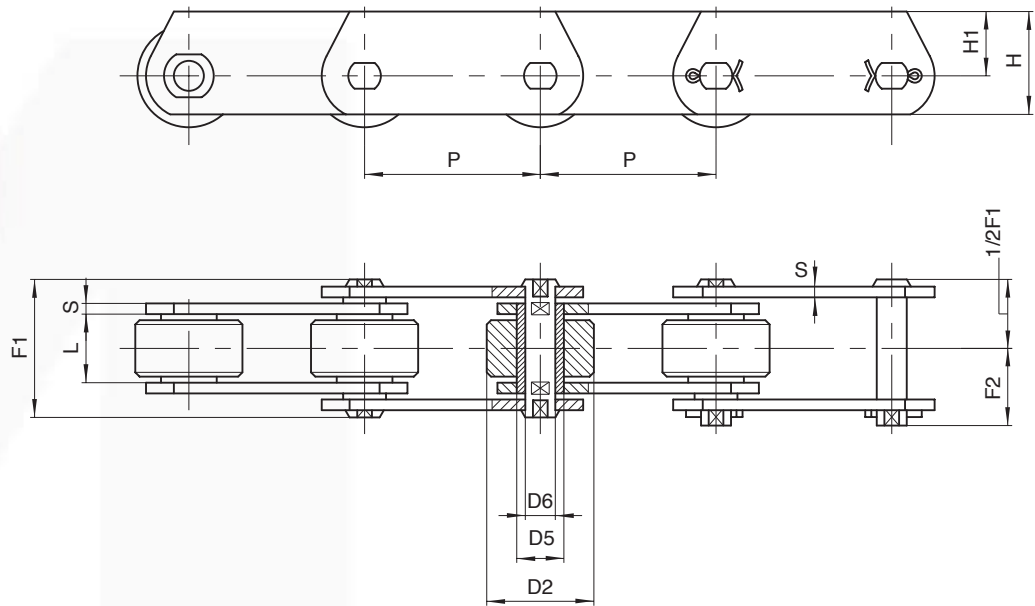

DEEP LINK CHAINS

Chain N.	P mm	L mm	D2 mm	D5 mm	D6 mm	H mm	H1 mm	S mm	F1 mm	F2 mm	Breaking load		Chain weight kg/m
											N	N*	
ME 450	200	56	120	42	30	120	80	12	114	67	450.000	700.000	47
"	250	"	"	"	"	"	"	"	"	"	"	"	41
"	315	"	"	"	"	"	"	"	"	"	"	"	36
"	400	"	"	"	"	"	"	"	"	"	"	"	32
ME 630	250	67	140	50	36	140	90	14	137	87,5	630.000	900.000	71
"	315	"	"	"	"	"	"	"	"	"	"	"	62,5
"	400	"	"	"	"	"	"	"	"	"	"	"	56
"	500	"	"	"	"	"	"	"	"	"	"	"	50,6
"	600	"	"	"	"	"	"	"	"	"	"	"	46,5
ME 900	250	78	170	60	44	180	120	16	153	95	900.000	1.250.000	108,5
"	315	"	"	"	"	"	"	"	"	"	"	"	94,5
"	400	"	"	"	"	"	"	"	"	"	"	"	82,5
"	500	"	"	"	"	"	"	"	"	"	"	"	73,8
"	600	"	"	"	"	"	"	"	"	"	"	"	66,7

(*) Breaking load with heat treated plates

Additional features:

- rollers of nylon, delrin, etc.
- in STAINLESS steel
- surface treatments of zinc plating, nickel plating, etc.
- pre-tensioned and labelled

