

catalogue

au

Endless handling
solutions

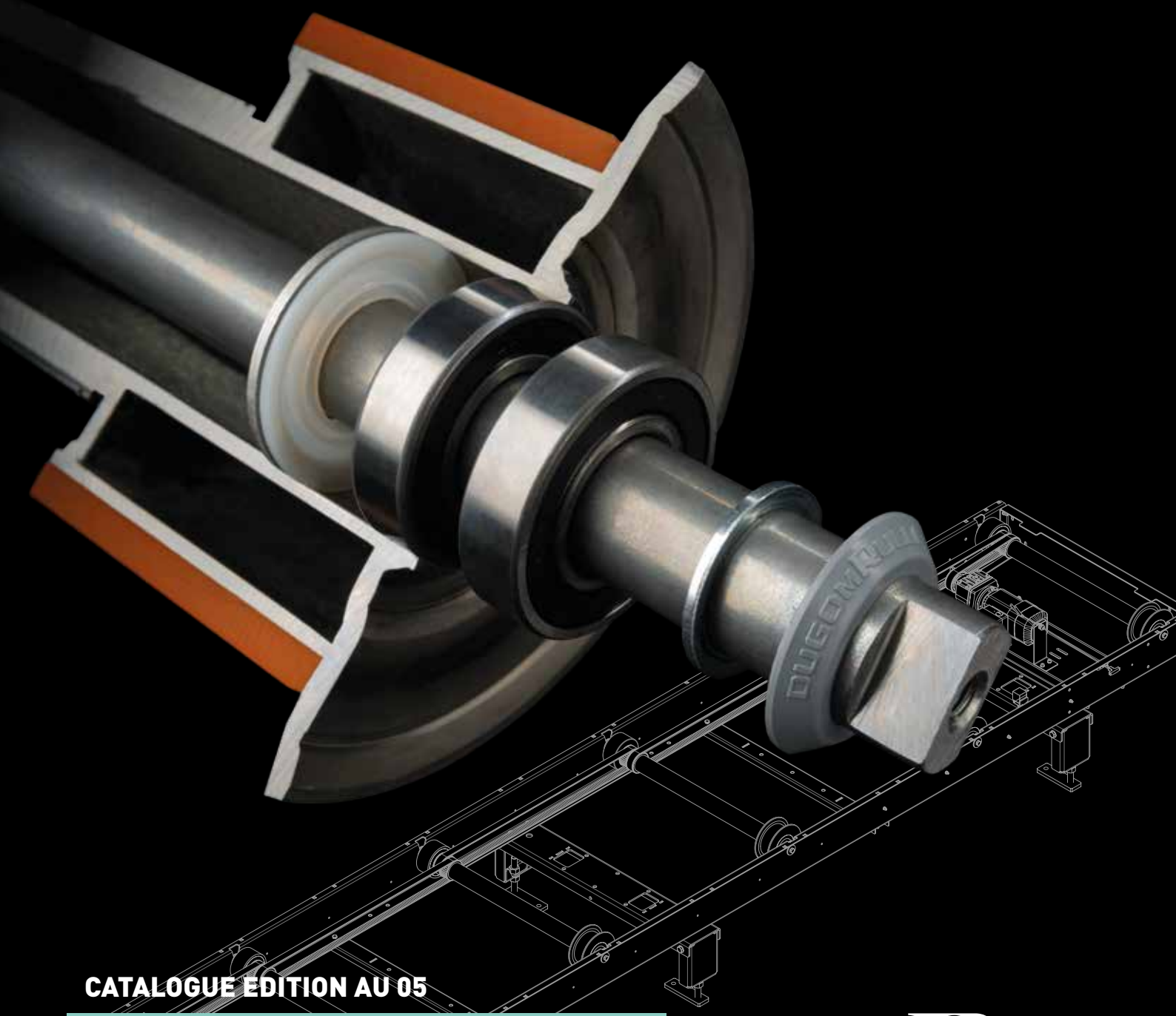

CATALOGUE EDITION AU 05

**AUTOMOTIVE MATERIALS HANDLINGS
DRIVE AND DRIVEN ROLLERS**

DUGOMRULLI
MOVING SOLUTIONS 

INDEX

DUGOMRULLI HISTORY	3
PRODUCT RANGE	5
AUTOMOTIVE ROLLER SOLUTIONS	7
DOUBLE WHEEL ROLLERS	9
SINGLE WHEEL ROLLERS	21
SPECIAL STEEL ROLLERS	27
DESIGN REQUIREMENTS	33
ASSEMBLY TOLERANCE ON ROLLERBEDS	38

PRODUCT RANGE	FLANGE DIA.	FLANGE INCLINATION	SHAFT DIA.	BELT/CHAIN	ROLLER CODE					
					SHAPE	POLYURETHANE COATED DRIVEN ROLLER	ALL STEEL DRIVEN ROLLER	POLYURETHANE COATED DRIVE ROLLER	ALL STEEL DRIVE ROLLER	
Double wheel rollers	125 mm dia.	165	35°	30	Z34 HTD 8M-55		329937W	329938W	-	-
		165	10°	25	Z34 HTD 8M-35		329822W	329823W	-	-
		165	10°	25	Z34 HTD 8M-35		329833W	329834W	-	-
		-	-	30	Z34 HTD 8M-55		329941	-	-	-
		190	20°	30	Z34 HTD 8M-55		329759V 329769V	329810V 329811V	332210V M8 332219V M8	332237V M8 332238V M8
	140 mm dia.	183	20°	30	Z34 HTD 8M-90		329638V	329809V	332192V M12 332249V M12	332236V M12
		183	20°	30	Z34 HTD 8M-55		329650W	329723W	-	-
		-	-	30	Z34 HTD 8M-55		329751N	-	-	-
		183	20°	30	Z34 HTD 8M-90		329656V	329746V	332188V M12	332212V M12
	158 mm dia.	210	25°	30	Z34 HTD 8M-55		329685W	329948W	-	-
Single wheel rollers	125 mm dia.	-	-	30	-		329807	-	-	-
		190	20°	30	Z34 HTD 8M-35		329808V	-	-	-
	140 mm dia.	183	20°	30	-		329803F	-	-	-
		183	20°	30	Z34 HTD 8M-35		329804V	-	-	-
		-	-	30	-		329805	-	-	-
		183	20°	30	Z34 HTD 8M-35		329806V	-	-	-
Special steel rollers	140 mm dia.	190	40°	30	Z34 HTD 8M-55		-	329942 IN	-	-
	158 mm dia.	210	25°	30	Z34 HTD 8M-35		-	329616	-	-
		210	25°	30	Z16 3/4"		-	329617	-	-

PRECISION AND QUALITY SINCE 1938
MOVING SOLUTIONS SINCE 1948
STRONG TRADITION FOR
CONTINUOUS INNOVATION





DUGOMRULLI HISTORY

The past, present and future of materials handling

From its first facilities, established back in 1938, to the current 17,000-square-meter production area not far from Bologna airport, **DugomRulli's** history has been characterized by continuous growth.

DugomRulli started its activities in 1938 producing tools and equipment for the cold forming of sheet metal.

In 1948 **DugomRulli** began the production of conveyor components, starting with chains and then moving on to rollers.

Since then, for three generations, **DugomRulli** has taken care of all customer needs, offering the best solutions available in the roller conveyor market.

This leading position is now ensured by the full automation of its welding and assembling production lines by one of the most versatile and best-performing ranges of handling products and by a UNI EN ISO 9001:2015 certified quality system.

DugomRulli is now synonymous with productivity, efficiency and technological skills in material handling.

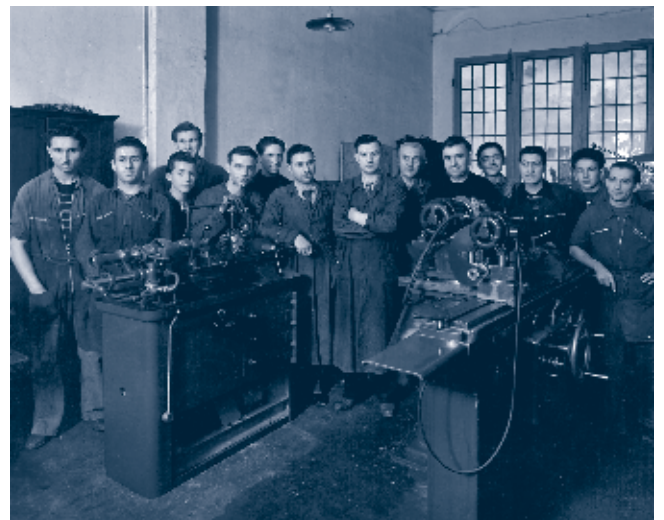

FLEXIBLE, CUSTOMIZED AND COMPLETE DUGOMRULLI'S PROPOSAL:

Unit handling
rollers: accuracy
catalogue
ci

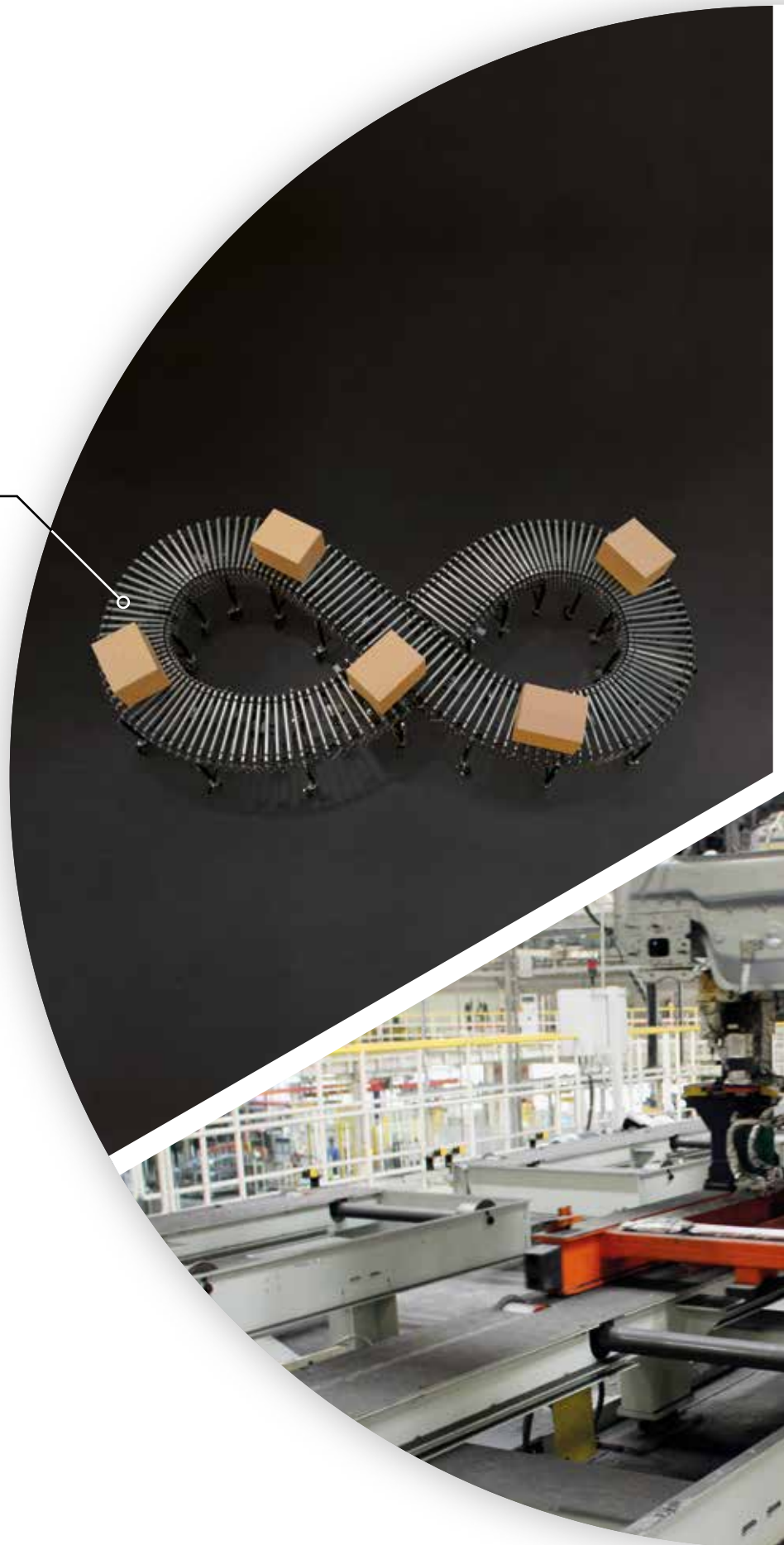



Bulk handling
rollers: endurance

catalogue
mr



Automotive
rollers: reliability

catalogue
au

ROLLERS FOR THE AUTOMOTIVE INDUSTRY

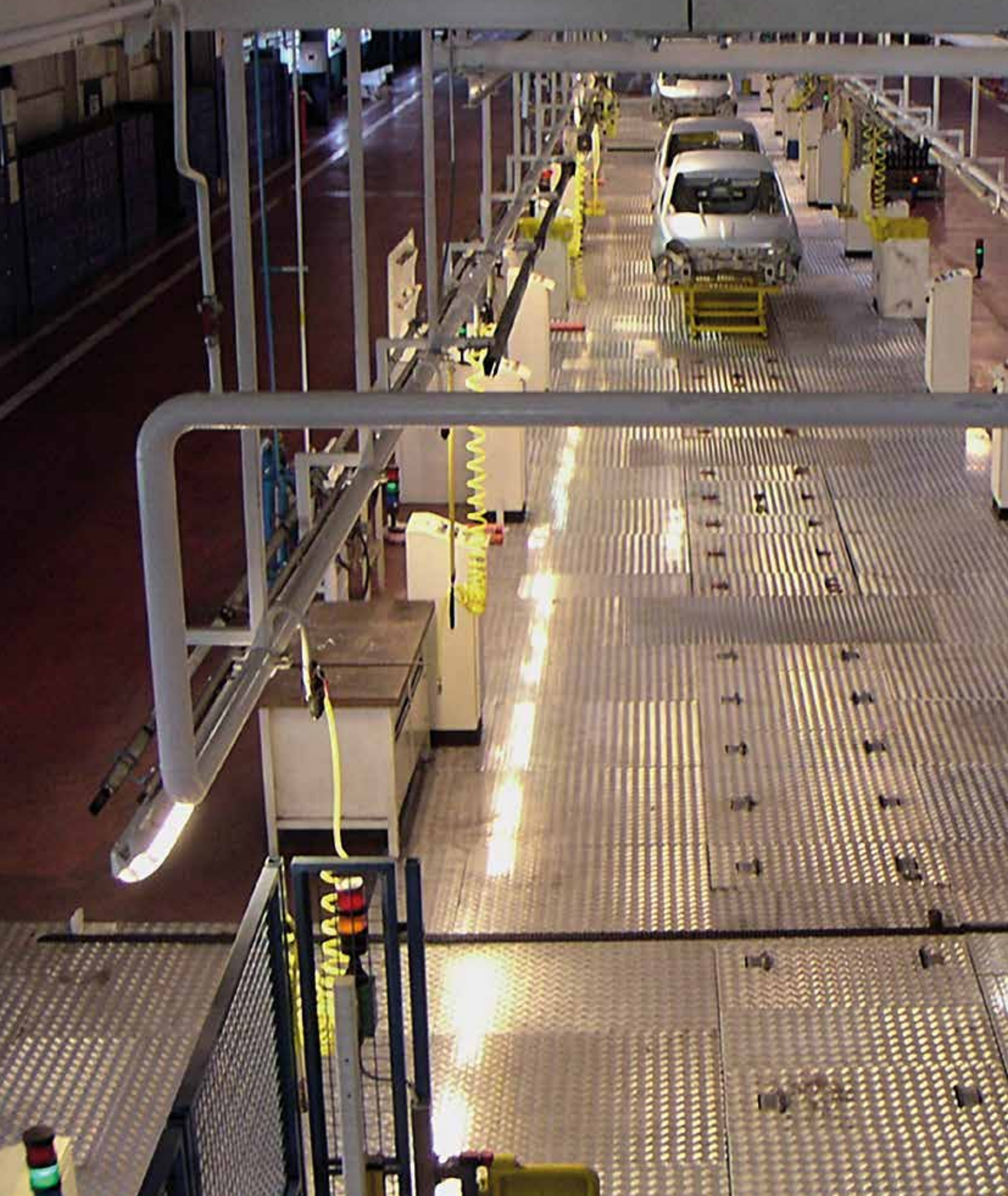



GENERAL FEATURES

The current level of competitiveness in the automotive sector has pushed the industry to require a much higher performances of its plants, where production takes place, with very high rates and continuous cycles of 2, sometimes 3 shifts a day for 6-7 days per week. This imposes the absolute reliability of the handling systems and their components, essential for optimizing the productivity and efficiency of the entire production cycle.

Over the years DugomRulli has been able to interpret the needs of a changing market, always offering fully reliable rollers with high-performance in wide operating conditions.

The main industrial applications served are the following:

- > the body building lines, characterized by very demanding cycle times, with severe acceleration and deceleration;
- > the painting lines, often at high working temperatures;
- > the assembly lines;
- > the transfer lines.

ASSEMBLY TOLERANCE ON ROLLERBEDS:

Correct alignment is essential for the rollers to operate properly, and their performance depends on the construction precision of the conveyors' framework.

For tolerances and other information, see this catalogue on page 38 as well as the USE AND MAINTENANCE MANUAL on our website.

PATENTS:

United States PATENT No. US9359145,

Italy PATENT No. IT0001429410

Europe (main European countries) PATENT No. EP2985245

PLEASE NOTE:

All roller designs presented in this catalog can be downloaded in 3D format.





DOUBLE WHEEL ROLLERS

These rollers are generally used for the handling of very rigid and heavy welding pallets as well as of assemblies (skids) for the most subservient to painting lines.

They are suitable for heavy duty working conditions, both in terms of moving masses and in terms of cycle times.

The unit load is supported by steel wheels coated with polyurethane 94 Shore A hardness, which provides excellent wear resistance, a high friction coefficient and low noise; the wheels 125, 140 or 158 mm diameters can be fitted with flanges that help to drive the unit load along the direction of motion.

All-steel rollers are also available, to be alternated with polyurethane coated rollers in order to discharge static charges.

The wheels are fixed to a diam. 70 mm tube made of electro-welded steel pipe according to the UNI EN 10025.

Single row deep groove ball bearings are housed inside the tube, according to ISO 492, ISO 76 and ISO 281; they are protected by means of contact seals and are lubricated for life.

The shaft is made of steel for structural use according to UNI EN 10025; the shaft ends are provided with tapped holes and millings for fixing the roller to the frame of the roller conveyor.

A double pulley is welded to the 70 mm diameter tube, between the two coated wheels. It allows the drive by means of a HTD 8M belt. The pulley is made of steel in accordance with UNI EN 10025.

A heavier execution, equipped with needle roller bearings, is available for very demanding working conditions.

"Drive rollers" are also available, which, placed in the middle of the conveyor and directly connected with the gear motor, transmit the motion to the remaining rollers.

The drive roller spindle is machined to allow perfect coupling with the gear motor and it is supported by external bearings mounted on the frame of the conveyor; the "driven rollers" receive motion through toothed belts.

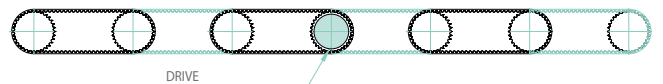

Technical note:

1. All coated rollers have no significant presence of silicon.
2. Loads of rollers are valid for:
 - standard environmental conditions;
 - working conditions indicated (speed, acceleration, etc.);
 - homogeneous distribution of the load on the rollers;
 - The bearings which equip the rollers are selected to ensure rated life 10.000 h - actual operation (90% reliability according to ISO specifications).
 - the pre-tension of the belts 1.360 N at 180° wrapped on the pulley;
 - conveyor configuration as shown in figure above.

General note:

For any other technical information and customized solutions, please contact our Technical Office.

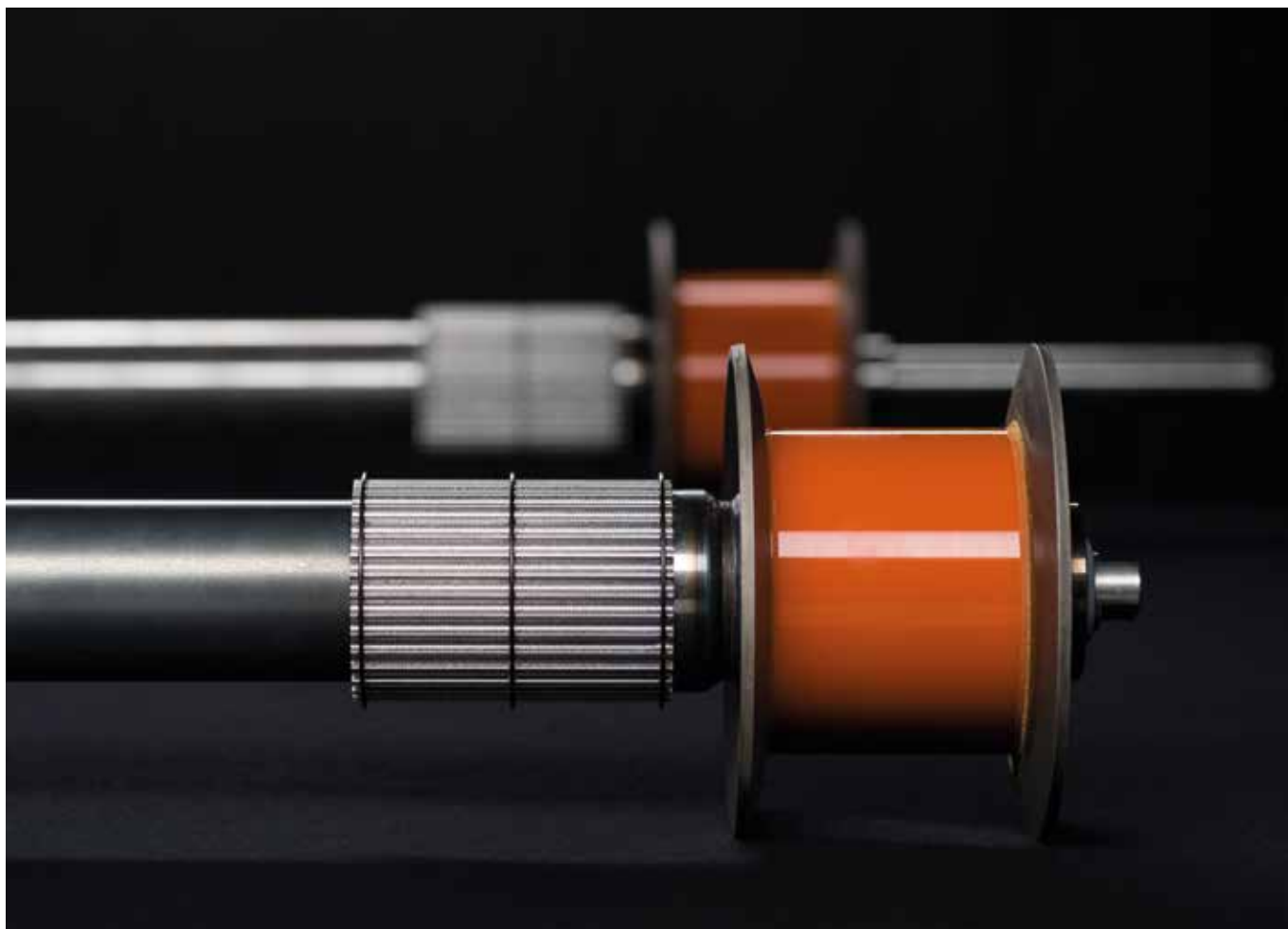

Operating condition				329937W 329938W	329822W 329823W	329833W 329834W	329941	329759V 329810V 332210V M8 332237V M8	329769V 329811V 332219V M8 332238V M8
Speed		Acc. Max	Length	Dynamic load capacity					
[m/min]	[rpm]	[m/s ²]	[mm]	[N]	[N]	[N]	[N]	[N]	[N]
20	51	≤ 1,5	≤ 1.300	9.500	5.840	4.800	7.900	7.900	12.190
30	76			8.950	5.300	4.370	6.900	6.900	12.190
40	102			8.400	4.950	4.080	6.270	6.270	12.190
50	127			7.500	4.700	3.850	5.800	5.800	12.190
60	153			6.700	4.520	3.700	5.980	5.980	11.900
70	178			6.150	4.370	3.600	5.200	5.200	11.050
80	204			5.700	4.250	3.500	4.970	4.970	10.210
90	229			5.200	4.150	3.400	4.780	4.780	9.360
100	255			5.000	4.050	3.350	4.620	4.620	8.500
110	280			4.500	3.960	3.270	4.470	4.470	7.670
120	306			4.000	3.900	3.200	4.350	4.350	6.820
Static load capacity				10.500	7.000	6.000	8.500	8.500	13.000

ROLLER CODE 329937W / 329938W

DIA. 125/70/30 Z34 HTD 8M-55

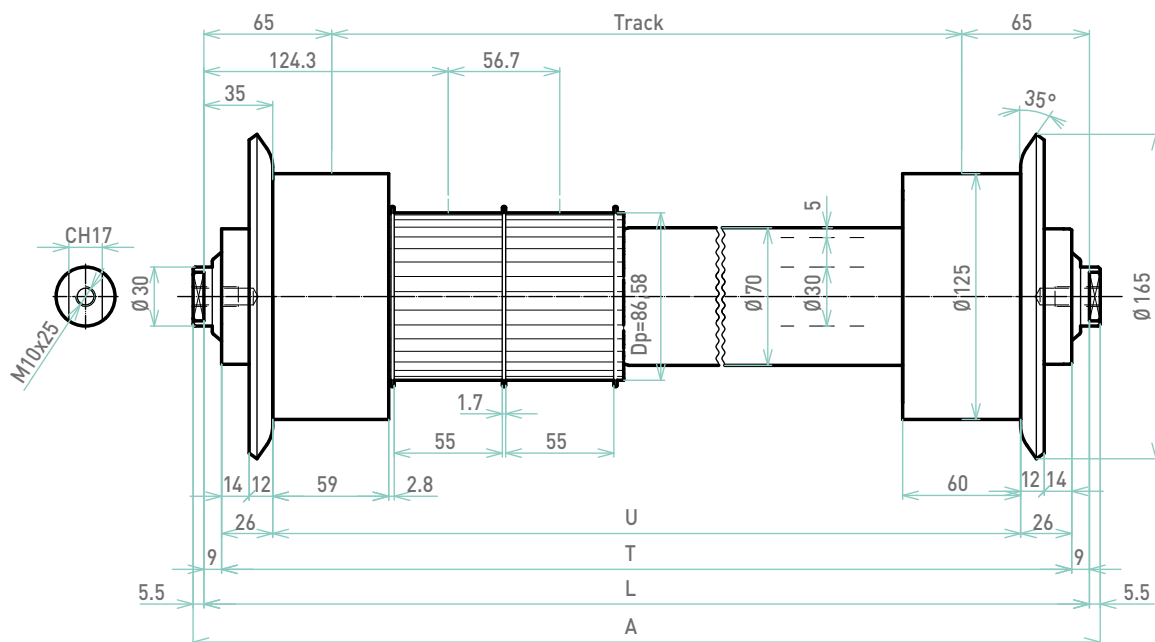

Items	Type	D	Coating	Bearing	T	A	U	Pulley
329937W	driven	125	Urethane	6206-2RS	L-18	L+11	L-70	Z34 HTD 8M-55
329938W	driven	125	Steel	6206-2RS	L-18	L+11	L-70	Z34 HTD 8M-55

ROLLER CODE 329822W / 329823W

DIA. 125/70/25 Z34 HTD 8M-35

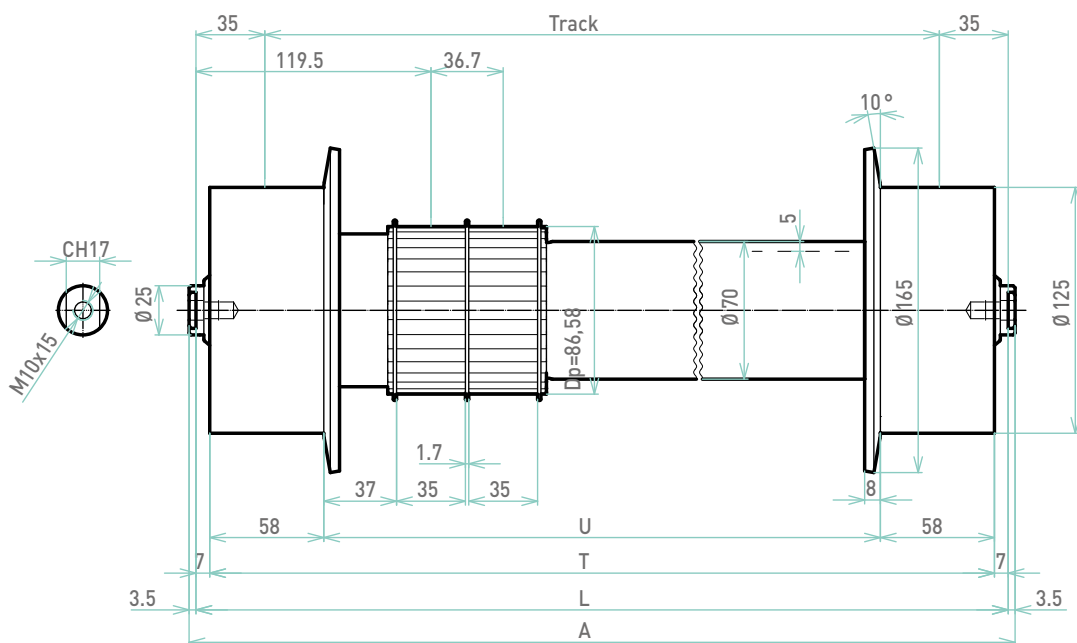

Items	Type	D	Coating	Bearing	T	A	U	Pulley
329822W	driven	125	Urethane	6305-2RS	L-14	L+7	L-130	Z34 HTD 8M-35
329823W	driven	125	Steel	6305-2RS	L-14	L+7	L-130	Z34 HTD 8M-35

ROLLER CODE 329759V / 329769V / 329810V / 329811V

DIA. 125/70/30 Z34 HTD 8M-55 HARDENED FLANGES

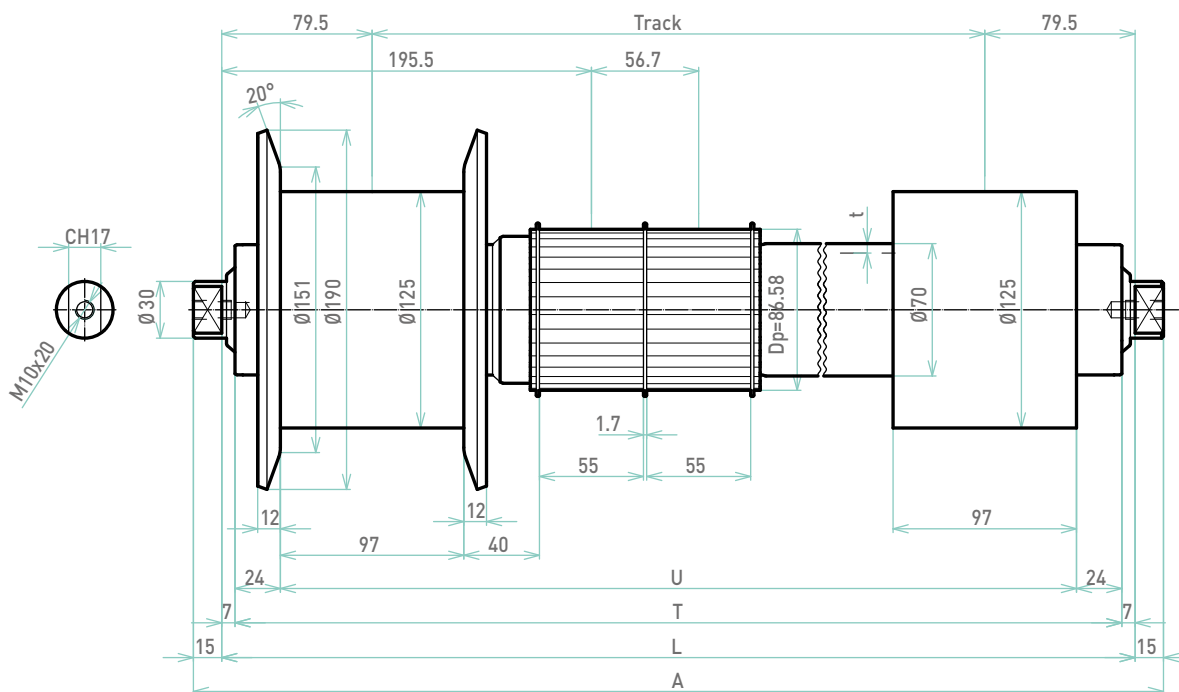

ROLLER CODE 332210V M8 / 332219V M8 / 332237V M8 / 332238V M8

DIA. 125/70/50/35 Z34 HTD 8M-55 HARDENED FLANGES

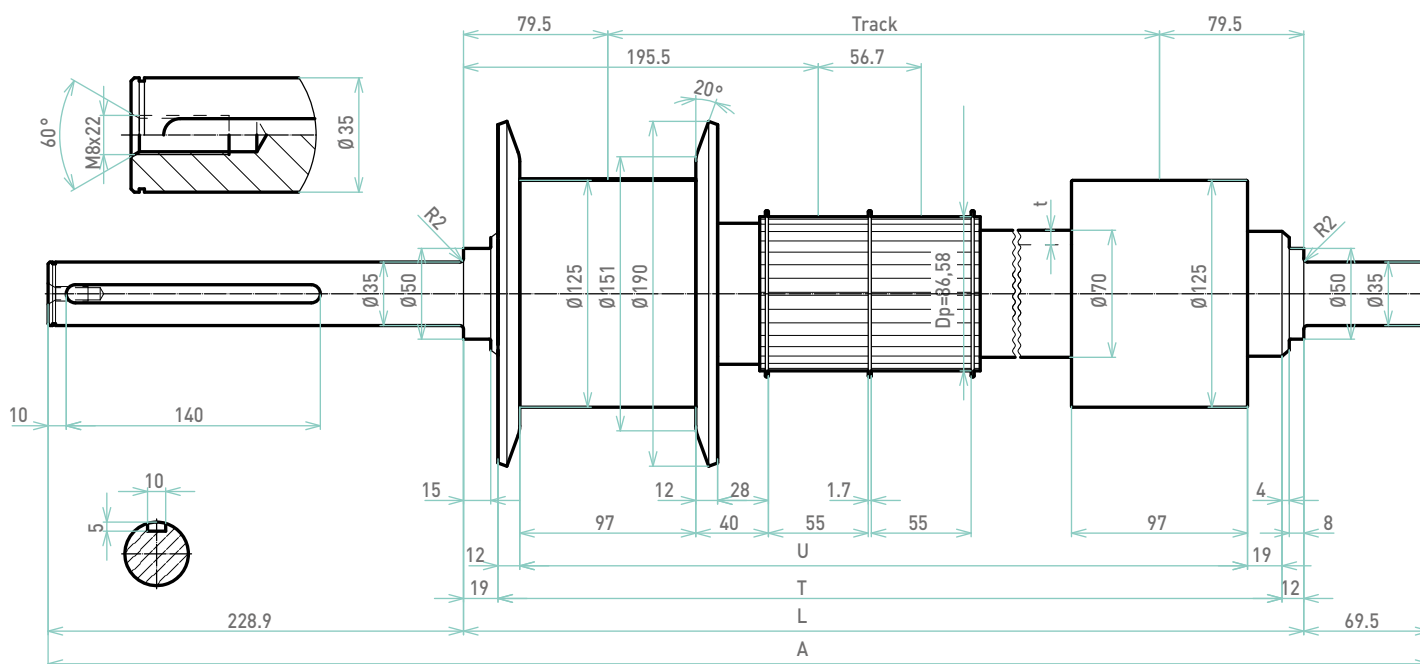

Items	Type	D	Coating	Bearing	t	T	A	U	Pulley
329759V	driven	125	Urethane	6206-2RS	5	L-14	L+30	L-62	Z34 HTD 8M-55
329769V	driven	125	Urethane	22206	8	L-14	L+30	L-62	Z34 HTD 8M-55
329810V	driven	125	Steel	6206-2RS	5	L-14	L+30	L-62	Z34 HTD 8M-55
329811V	driven	125	Steel	22206	8	L-14	L+30	L-62	Z34 HTD 8M-55
332210V M8	drive	125	Urethane	-	8	L-31	L+298,4	L-62	Z34 HTD 8M-55
332219V M8	drive	125	Urethane	-	10	L-31	L+298,4	L-62	Z34 HTD 8M-55
332237V M8	drive	125	Steel	-	8	L-31	L+298,4	L-62	Z34 HTD 8M-55
332238V M8	drive	125	Steel	-	10	L-31	L+298,4	L-62	Z34 HTD 8M-55

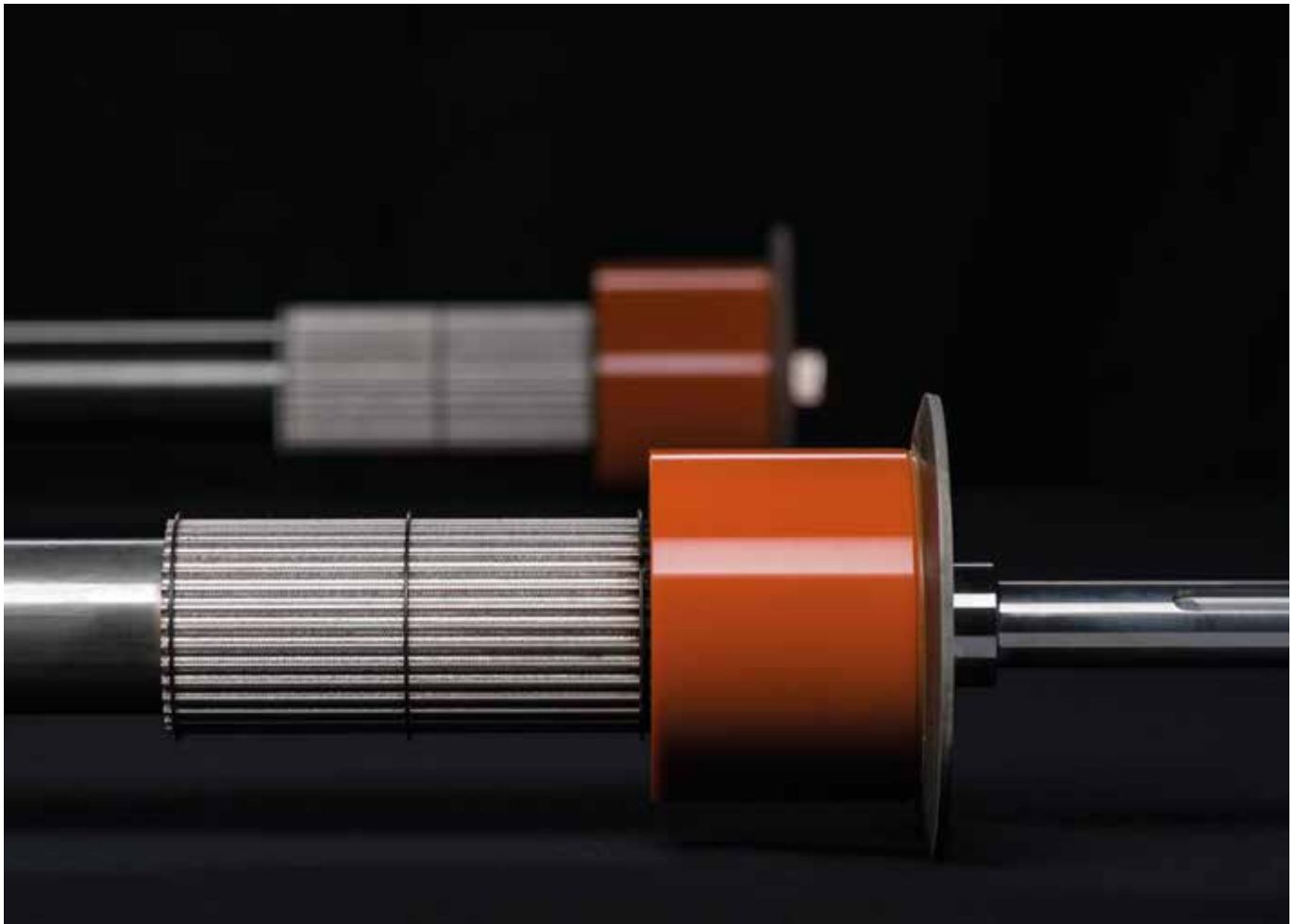

Operating condition				329638V 329809V 332192V M12 332249V M12 332236V M12	329650W 329723W	329751N	329656V 329746V 332188V M12 332212V M12
Speed		Acc. Max	Length	Dynamic load capacity			
[m/min]	[rpm]	[m/s ²]	[mm]	[N]	[N]	[N]	[N]
20	45	≤ 1,5	≤ 1.300	11.200	8.200	8.200	13.130
30	68			10.800	7.170	7.170	11.470
40	91			10.400	6.510	6.510	10.421
50	114			9.600	6.050	6.050	9.674
60	136			9.100	5.600	5.600	9.104
70	159			8.650	5.400	5.400	8.648
80	182			8.270	5.170	5.170	8.271
90	205			7.900	4.970	4.970	7.953
100	227			7.678	4.800	4.800	7.678
110	250			7.400	4.650	4.650	7.438
120	273			7.200	4.510	4.510	7.226
130	296			7.000	-	-	7.035
140	318			6.850	-	-	6.864
150	341			6.200	-	-	6.708
Static load capacity				12.300	9.000	9.000	15.000

ROLLER CODE 329638V / 329809V

DIA. 140/70/30 Z34 HTD 8M-90 HARDENED FLANGES

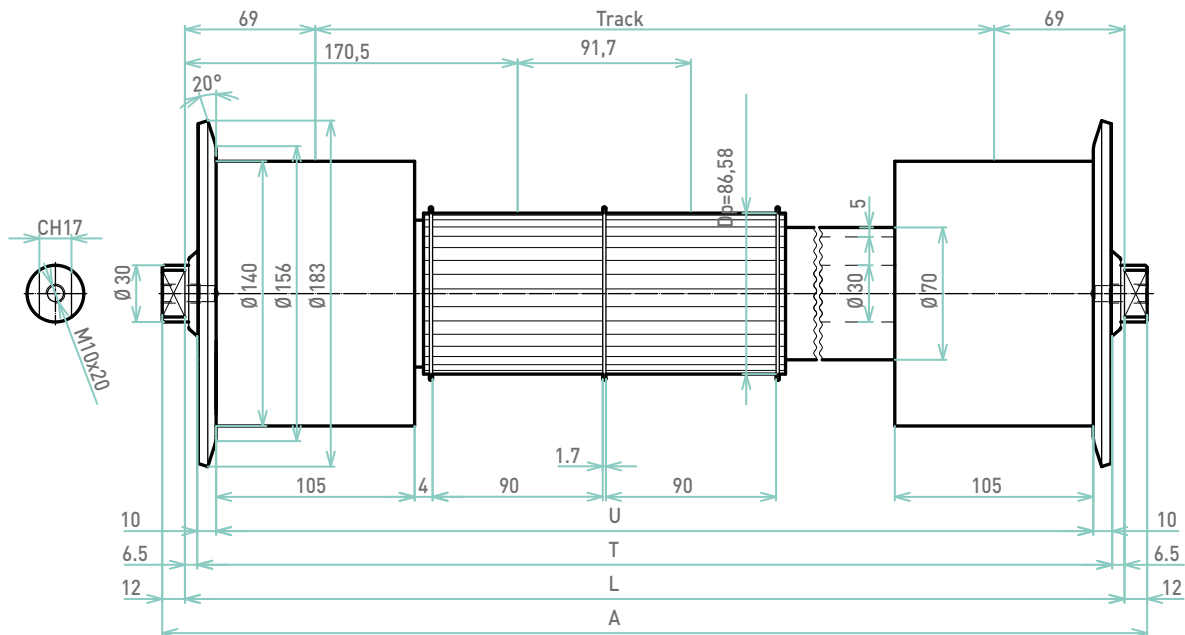

ROLLER CODE 332192V M12 / 332249V M12 / 332236V M12

DIA. 140/70/50/35 Z34 HTD 8M-90 HARDENED FLANGES

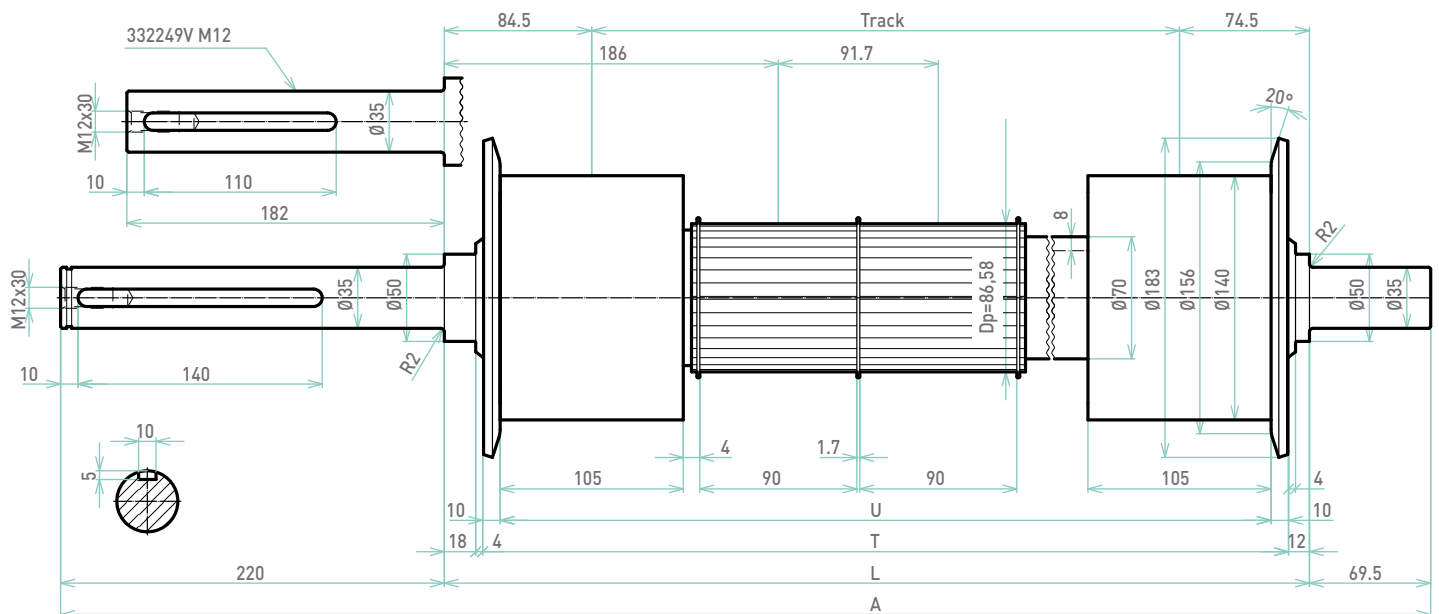

Items	Type	D	Coating	Bearing	T	A	U	Pulley
329638V	driven	140	Urethane	6206-2RS	L-13	L+24	L-33	Z34 HTD 8M-90
329809V	driven	140	Steel	6206-2RS	L-13	L+24	L-33	Z34 HTD 8M-90
332192V M12	drive	140	Urethane	-	L-34	L+289,5	L-54	Z34 HTD 8M-90
332249V M12	drive	140	Urethane	-	L-34	L+251,5	L-54	Z34 HTD 8M-90
332236V M12	drive	140	Steel	-	L-34	L+289,5	L-54	Z34 HTD 8M-90

ROLLER CODE 329650W / 329723W

DIA. 140/70/30 Z34 HTD 8M- 55

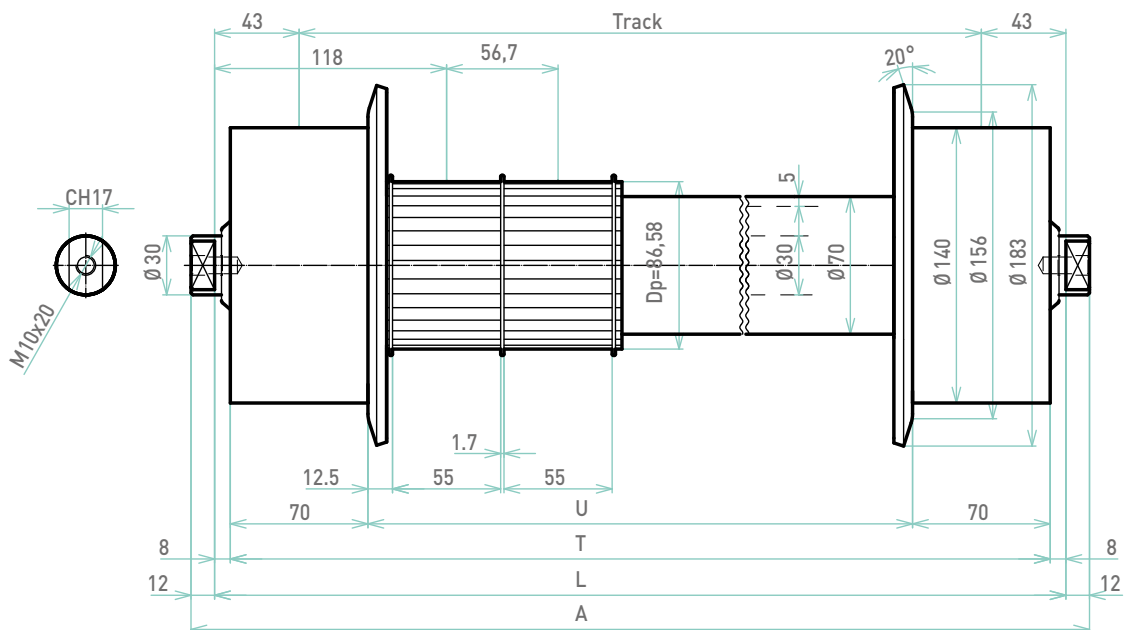

Items	Type	D	Coating	Bearing	T	A	U	Pulley
329650W	driven	140	Urethane	6206-2RS	L-16	L+24	L-156	Z34 HTD 8M-55
329723W	driven	140	Steel	6206-2RS	L-16	L+24	L-156	Z34 HTD 8M-55

ROLLER CODE 329751N

DIA. 140/70/30 Z34 HTD 8M-55

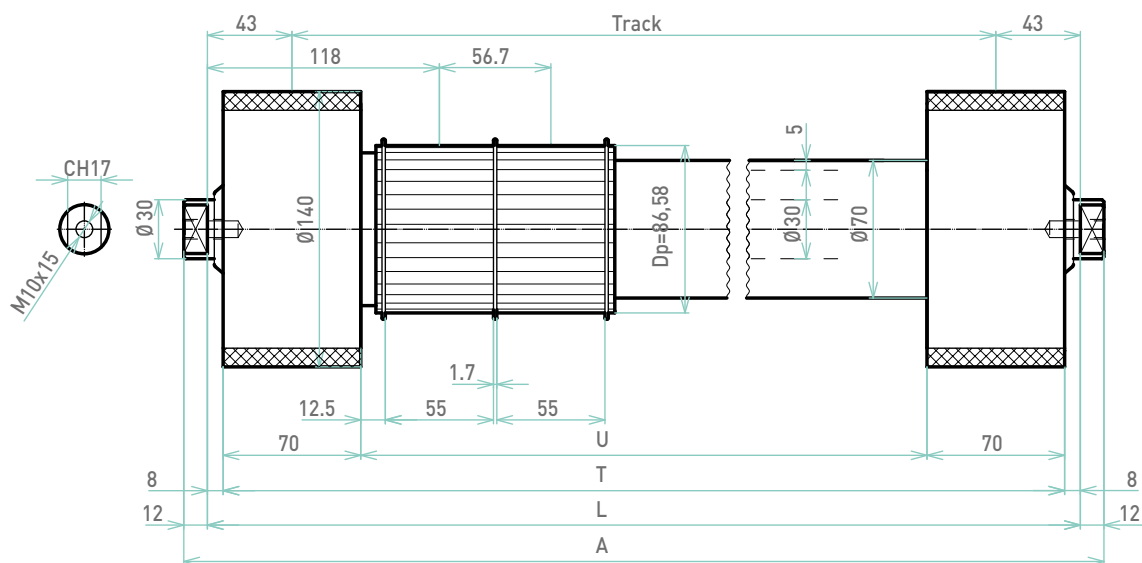

Items	Type	D	Coating	Bearing	T	A	U	Pulley
329751N	driven	140	Urethane	6206-2RS	L-16	L+24	L-156	Z34 HTD 8M-55

ROLLER CODE 329656V / 329746V

DIA. 140/70/30 Z34 HTD 8M-90 HARDENED FLANGES

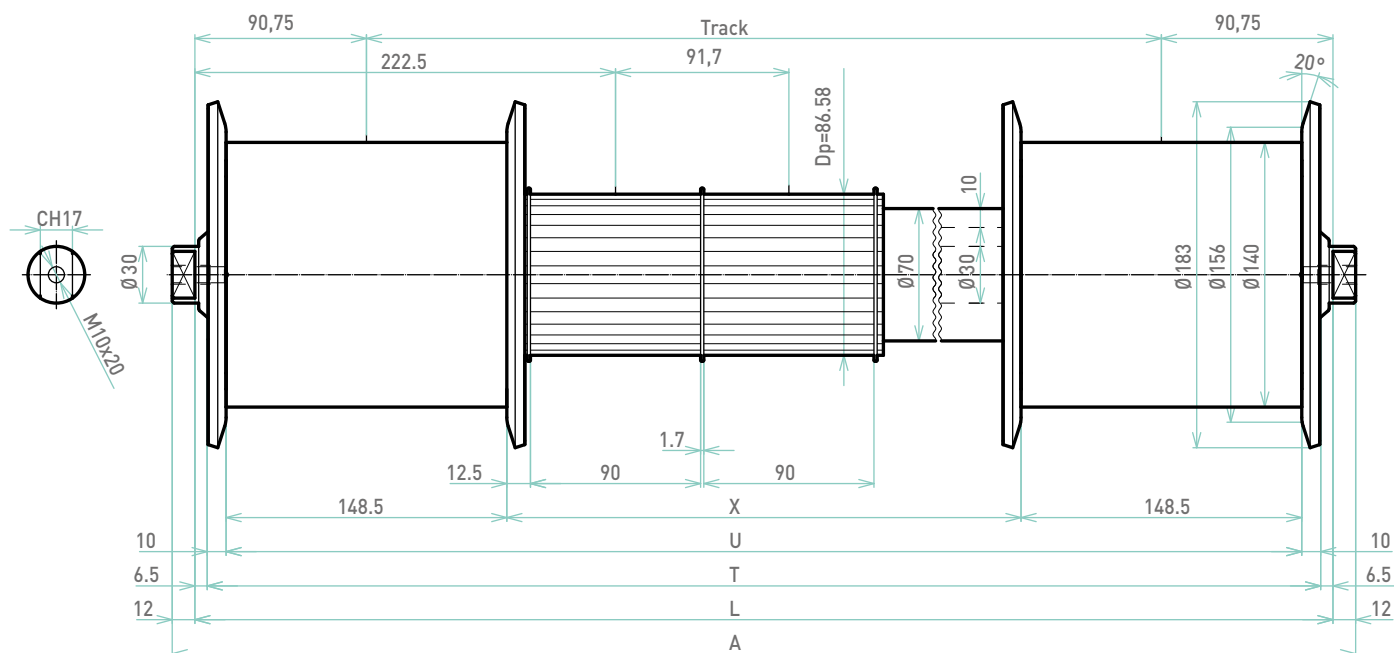

ROLLER CODE 332188V M12 / 332212V M12

DIA. 140/70/50/35 Z34 HTD 8M-90 HARDENED FLANGES

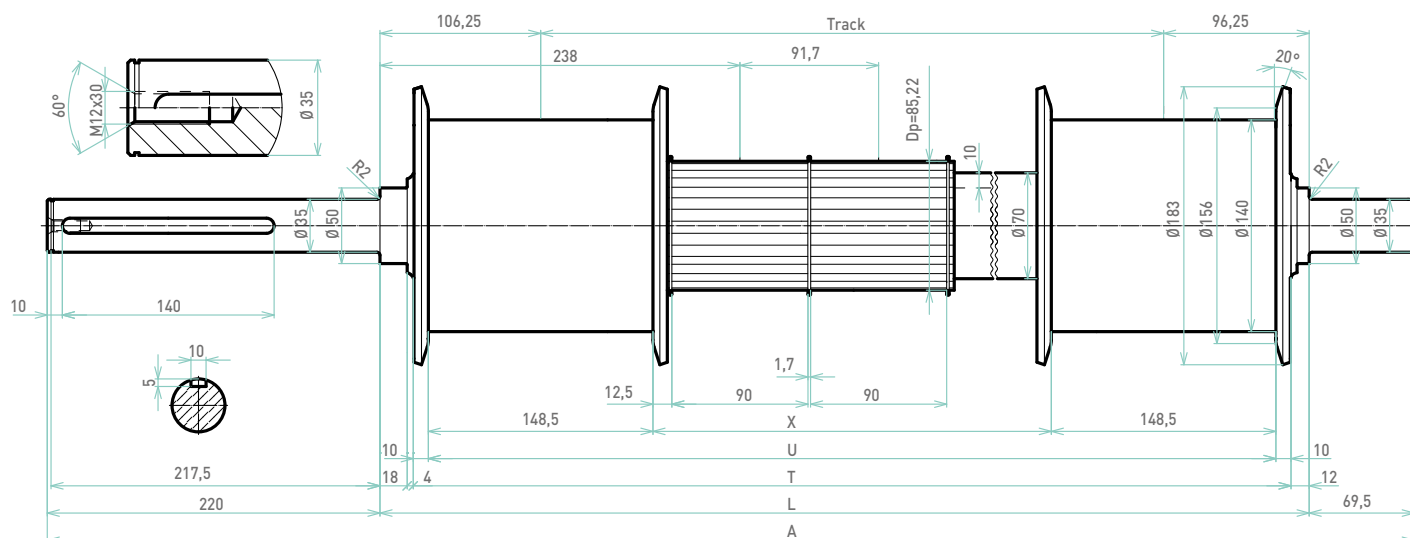

Items	Type	D	Coating	Bearing	T	A	U	Pulley
329656V	driven	140	Urethane	6206-2RS	L-13	L+24	L-33	Z34 HTD 8M-90
329746V	driven	140	Steel	6206-2RS	L-13	L+24	L-33	Z34 HTD 8M-90
332188V M12	drive	140	Urethane	-	L-34	L+289,5	L-54	Z34 HTD 8M-90
332212V M12	drive	140	Steel	-	L-34	L+289,5	L-54	Z34 HTD 8M-90

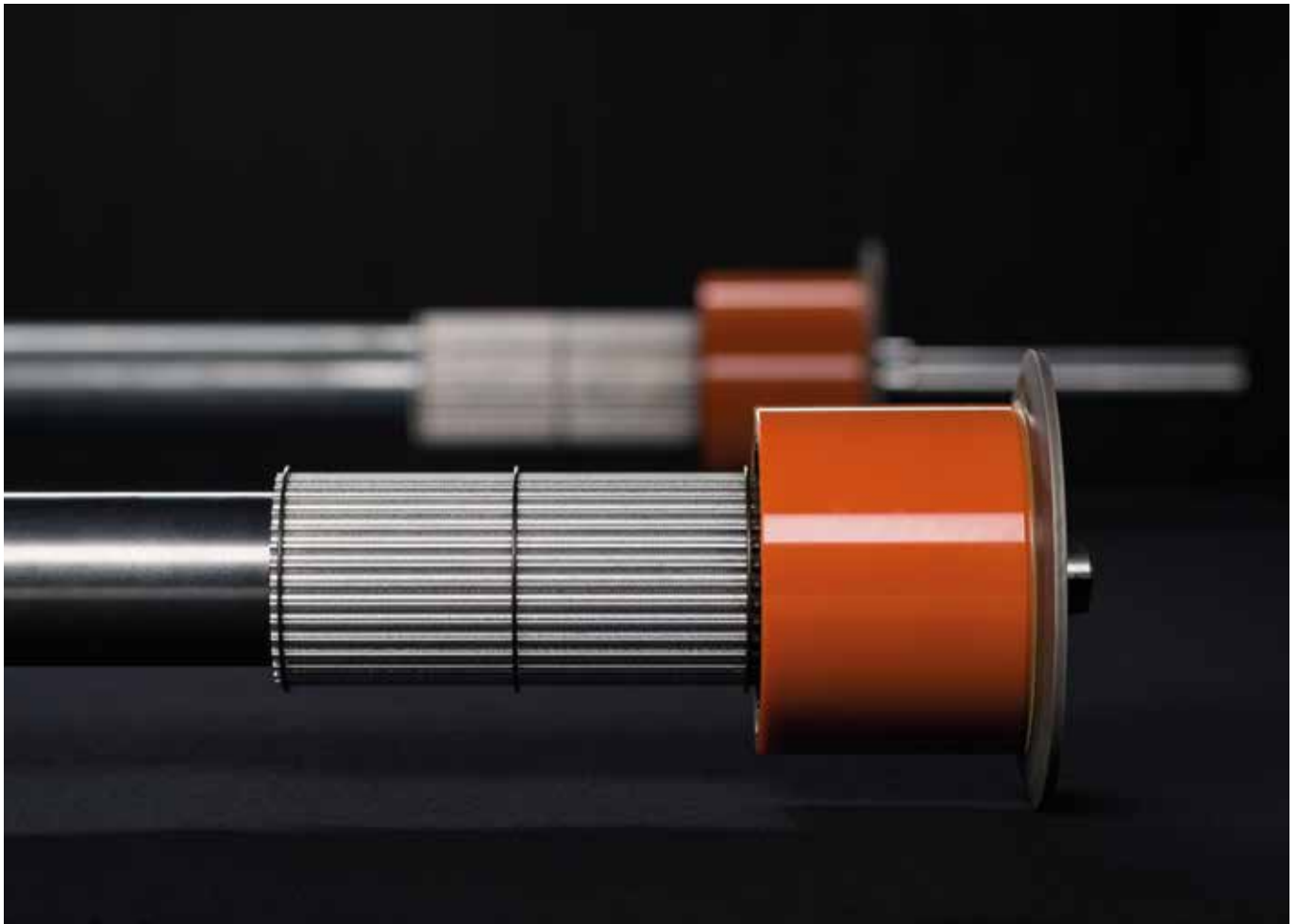

Operating condition				329685W 329948W
Speed		Acc. Max	Length	Dynamic load capacity
[m/min]	[rpm]	[m/s ²]	[mm]	[N]
20	40	≤ 1,5	≤ 1.300	7.620
30	60			7.100
40	81			6.770
50	101			6.250
60	121			5.900
70	141			5.600
80	161			5.380
90	181			5.170
100	202			4.950
110	222			4.830
120	242			4.700
Static load capacity				9.500

ROLLER CODE 329685W / 329948W
 DIA. 158/70/30 Z34 HTD 8M-55

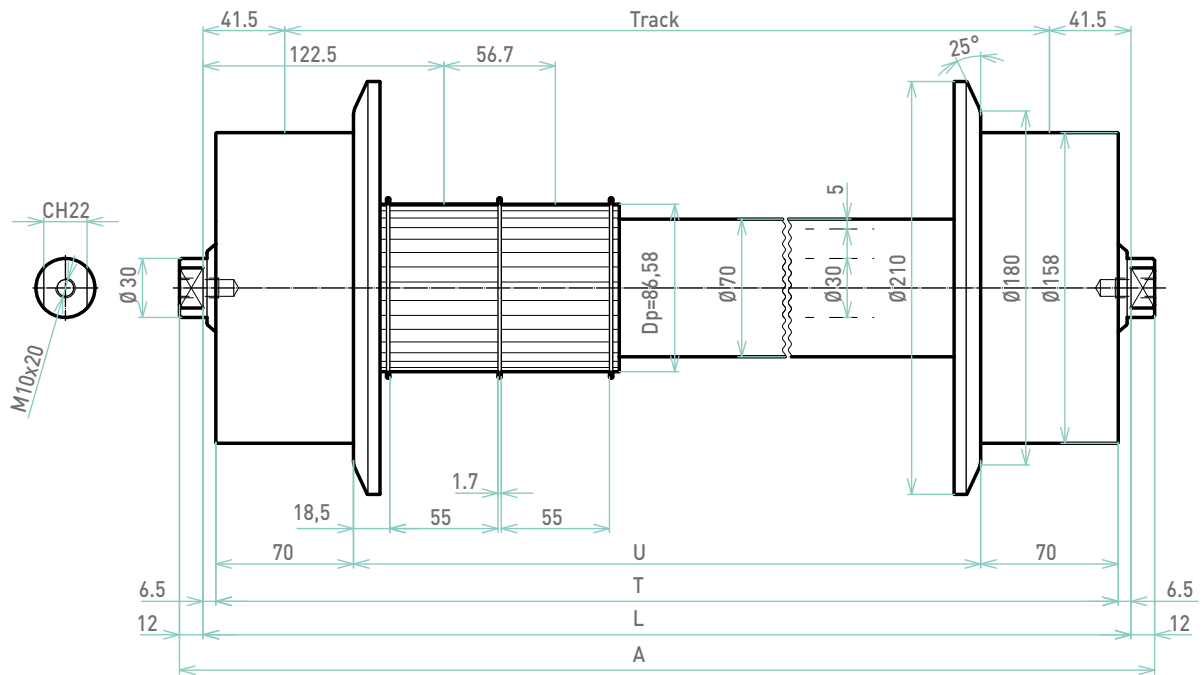

Items	Type	D	Coating	Bearing	T	A	U	Pulley
329685W	driven	158	Urethane	6206-2RS	L-13	L+24	L-153	Z34 HTD 8M-55
329948W	driven	158	Steel	6206-2RS	L-13	L+24	L-153	Z34 HTD 8M-55







SINGLE WHEEL ROLLERS

These rollers are mounted parallel, one for each side of the load, and not connected to each other. They are suitable for medium and heavy working conditions for the same working conditions of the double wheel rollers and can move very wide unit loads.

They are usually driven by means of HTD 8M belts and are provided with a steel wheel coated with polyurethane 94 Shore A hardness, which provides excellent wear resistance, high friction coefficient and low noise. The wheels are 125 or 140 mm diameters and can be fitted with flanges that help drive the unit load along the direction of motion.

The wheel is fixed to diam. 70 mm tube made of electro-welded steel pipe according to the UNI EN 10025.

All-steel rollers are also available, to be alternated with polyurethane coated rollers in order to discharge static charges.

Single row deep groove ball bearings are housed inside the tube, according to ISO 492, ISO 76 and ISO 281. They are protected by means of contact seals and are lubricated for life.

The shaft is made of steel for structural use according to UNI EN 10025; the shaft ends are provided with tapped holes and millings for fixing the roller to the frame of the roller conveyor.

Generally, when mounted in parallel, one roller is equipped with a double pulley made in steel according to UNI EN 10025 for the toothed belt series HTD-8M, while the other one is idle.

The driven roller has at least one flange and the idle one can have one, two or no flanges.

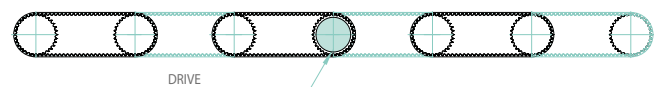

Technical note:

1. All coated rollers have no significant presence of silicon.
2. It is possible to provide the rollers with antistatic metal wheels.
3. Loads of rollers are valid for
 - standard environmental conditions;
 - working conditions indicated (speed, acceleration, etc.);
 - homogeneous distribution of the load on the rollers;
 - The bearings which equip the rollers are selected to ensure rated life 10.000 h - actual operation (90% reliability according to ISO specifications).
 - the pre-tension of the belts 650 N at 180° wrapped on the pulley;
 - conveyor configuration as shown in figure above.

General note:

For any other technical information and customized solutions, please contact our Technical Office.



Operating condition			329807 329808V
Speed		Acc. Max	Dynamic load capacity
[m/min]	[rpm]	[m/s ²]	[N]
20	51	≤ 1,5	5.002
30	76		4.370
40	102		3.970
50	127		3.686
60	153		3.468
70	178		3.295
80	204		3.151
90	229		3.030
100	255		2.925
110	280		2.834
120	306		2.753
Static load capacity			5.500

ROLLER CODE 329807

DIA. 125/70/30

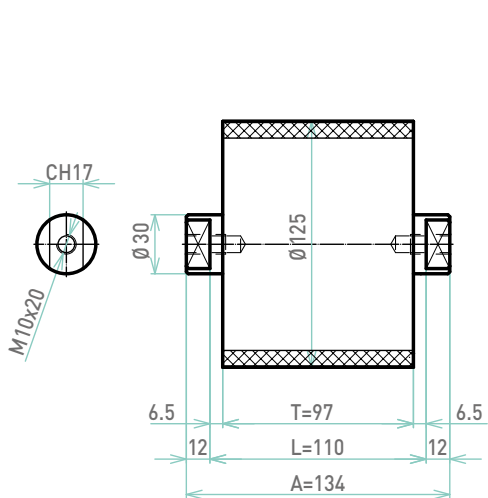

ROLLER CODE 329808V

DIA. 125/70/30 Z34 HTD 8M-35

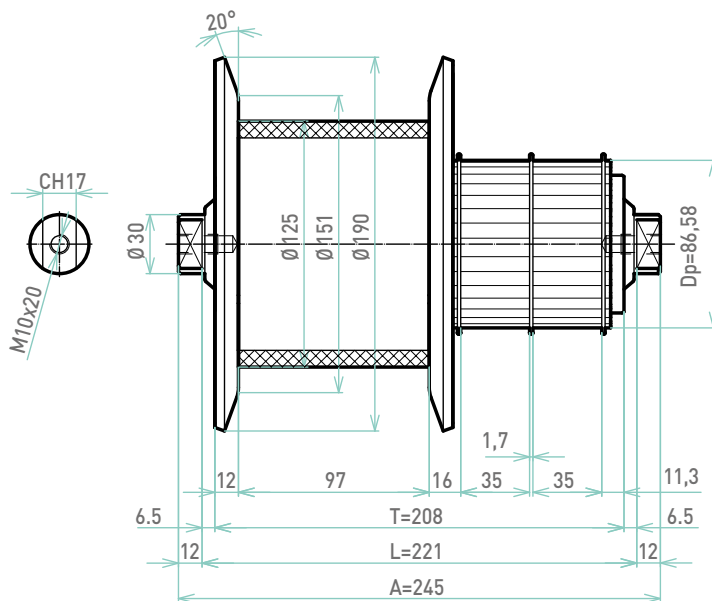

Items	Type	D	Bearing	L	T	A	Pulley
329807	idle	125	6206-2RS	110	97	134	-
329808V	driven	125	6206-2RS	221	208	245	Z34 HTD 8M-35





Operating condition			329803F 329804V	329805 329806V
Speed		Acc. Max	Dynamic load capacity	
[m/min]	[rpm]	[m/s ²]	[N]	[N]
20	45	≤ 1,5	5.359	5.177
30	68		4.682	4.522
40	91		4.253	4.109
50	114		3.949	3.814
60	136		3.716	3.589
70	159		3.530	3.409
80	182		3.376	3.261
90	205		3.246	3.135
100	227		3.134	3.027
110	250		3.036	2.933
120	273		2.946	2.849
Static load capacity			5.700	5.400

ROLLER CODE 329803F

DIA. 140/70/30 HARDENED FLANGE

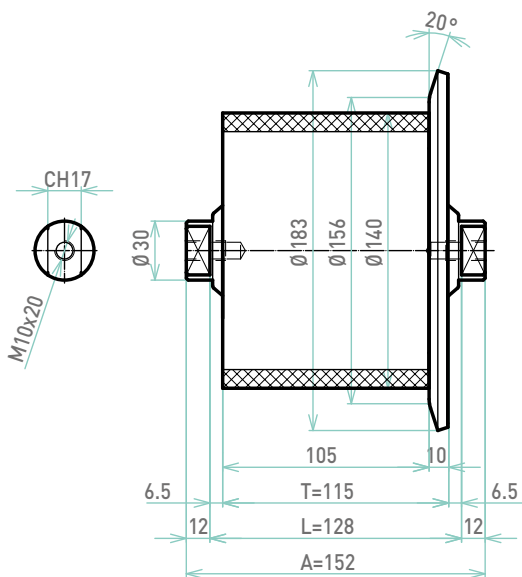

ROLLER CODE 329804V

DIA. 140/70/30 Z34 HTD 8M-35 HARDENED FLANGES

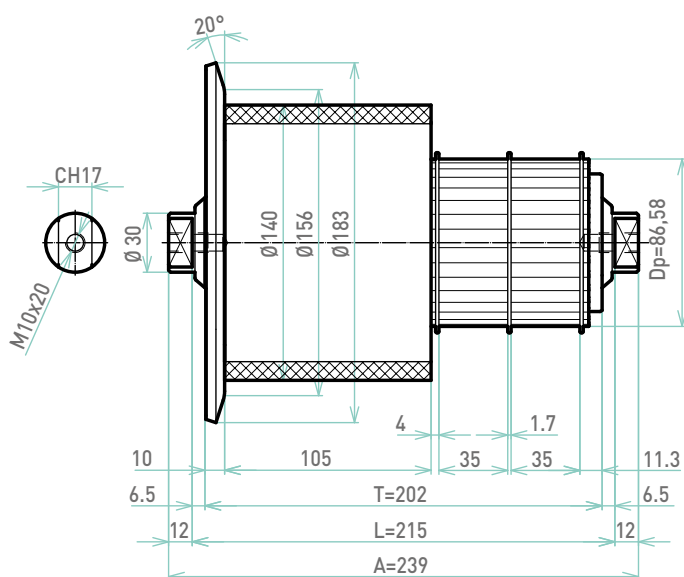

Items	Type	D	Bearing	L	T	A	Pulley
329803F	idle	140	6206-2RS	128	115	152	-
329804V	driven	140	6206-2RS	215	202	239	Z34 HTD 8M-35

ROLLER CODE 329805

DIA. 140/70/30

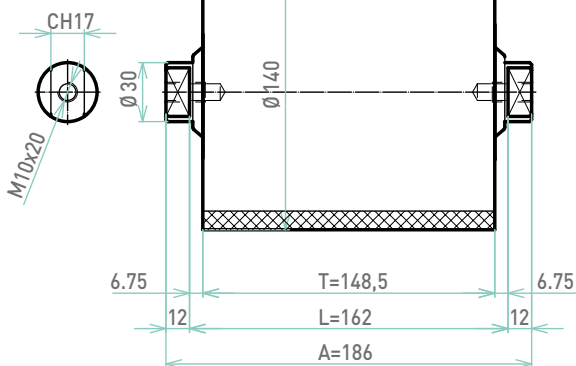

ROLLER CODE 329806V

DIA. 140/70/30 Z34 HTD 8M-35 HARDENED FLANGES

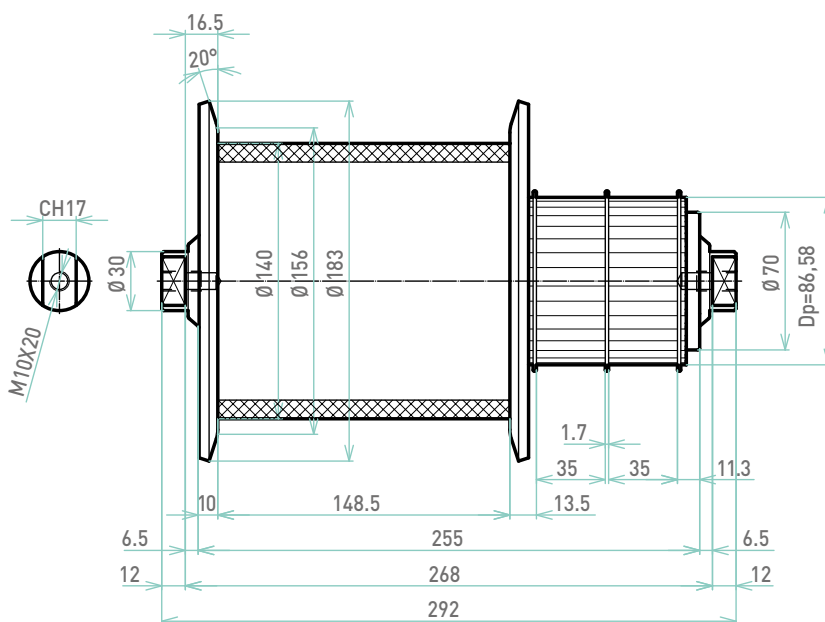

Items	Type	D	Bearing	L	T	A	Pulley
329805	idle	140	6206-2RS	162	148,5	186	-
329806V	driven	140	6206-2RS	268	255	292	Z34 HTD 8M-35





SPECIAL DOUBLE WHEEL STEEL ROLLERS

These uncoated rollers are suitable for medium working conditions, both in terms of moving masses and in terms of cycle times. In particular they are not suitable, however, for high speed and accelerations due to the low coefficient of friction and the high noise in the contact of steel on steel.

They can be provided with soundproof wheels fitted within an inside ring of isostatic polypropylene.

Some types are driven through chains and can be used in high temperature environments.

The wheels are fitted with flanges that help drive the unit load along the direction of motion and are fixed to a diam. 70 mm tube made of electro-welded steel pipe according to the UNI EN 10025.

Single row deep groove ball bearings are housed inside the tube, according to ISO 492, ISO 76 and ISO 281; they are protected by means of contact seals and are lubricated for life.

The shaft is made of steel for structural use according to UNI EN 10025; the shaft ends are provided with tapped holes and millings for fixing the roller to the frame of the roller conveyor.

The rollers can be driven by a toothed belt HTD 8M series through a double pulley or by chains through steel sprockets series ISO 12B, both in steel according to UNI EN 10025.

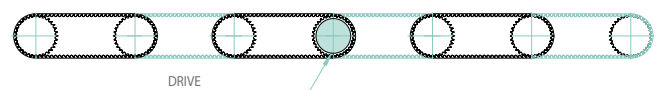

Technical note:

1. All coated rollers have no significant presence of silicon.
 - Loads of rollers are valid for:
 - standard environmental conditions;
 - working conditions indicated (speed, acceleration, etc.);
 - homogeneous distribution of the load on the rollers;
 - The bearings which equip the rollers are selected to ensure rated life 10.000 h - actual operation (90% reliability according to ISO specifications).
 - the pre-tension of the belts 1.360 N at 180° wrapped on the pulley;
 - conveyor configuration as shown in figure above.

General note:

For any other technical information and customized solutions, please contact our Technical Office.



Operating condition			329942 IN	
Speed		L	Dynamic load capacity	
[m/min]	[rpm]	[mm]	[N]	
10	23	≤ 1,300	9.500	
20	45		8.200	
30	68		7.150	
40	91		6.500	
50	114		6.020	
60	136		5.690	
70	159		5.400	
80	182		5.150	
90	205		4.970	
100	227		4.730	
Static load capacity			10.000	

ROLLER CODE 329942 IN

DIA. 140/70/30 Z34 HTD 8M-55

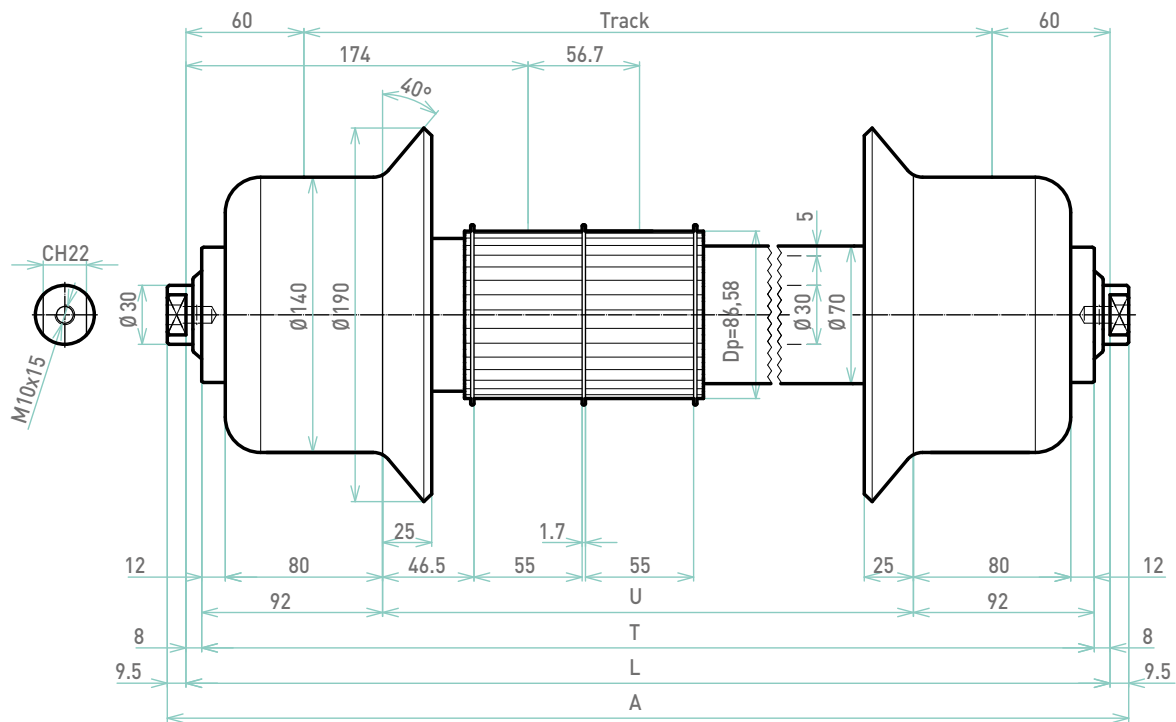

Items	Type	D	Bearing	T	A	U	Pulley
329942 IN	driven	140	6206-2RS	L-16	L+19	L-200	Z34 HTD 8M-55





Operating condition			329616	329617
Speed		L	Dynamic load capacity	
[m/min]	[rpm]	[mm]	[N]	[N]
10	20	≤ 1.300	10.500	10.500
20	40		8.540	8.540
30	60		7.460	7.460
40	81		6.780	6.780
50	101		6.250	6.250
60	121		5.920	5.920
70	141		5.600	5.600
80	161		5.350	5.350
90	181		5.150	-
100	201		4.950	-
Static load capacity			11.000	11.000

ROLLER CODE 329616

DIA. 158/70/30 Z34 HTD 8M-35

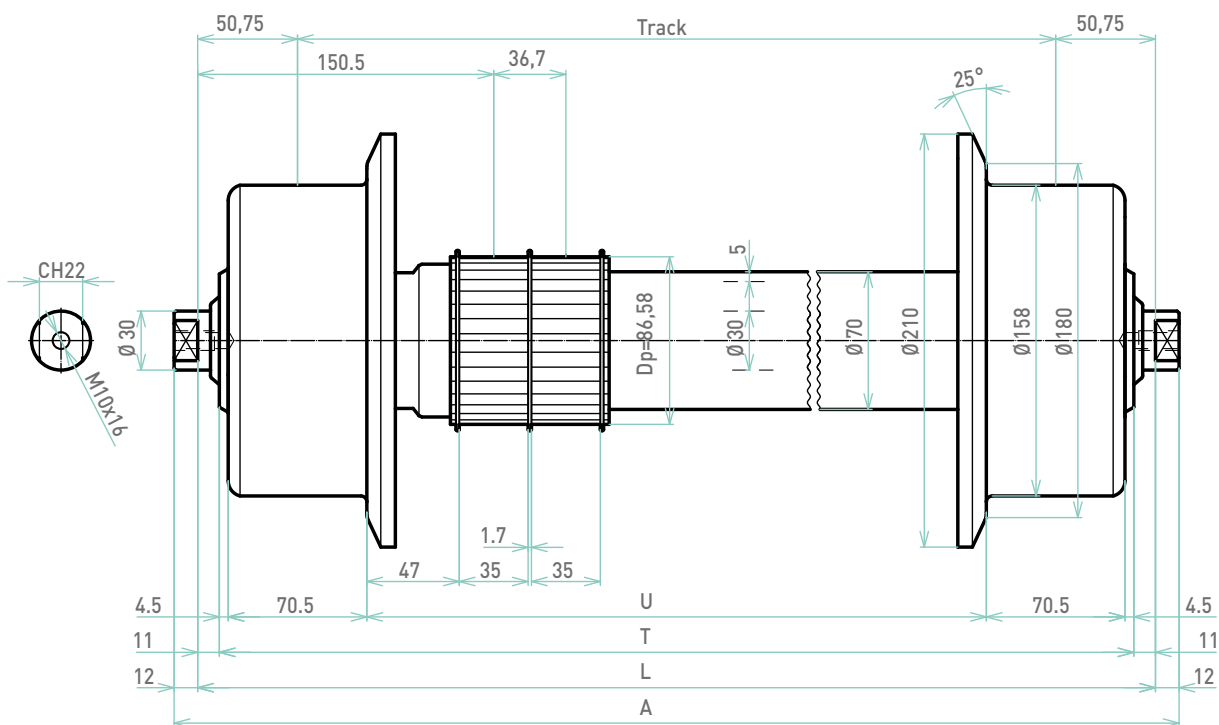

Items	Type	D	Bearing	T	A	U	Pulley
329616	driven	158	6206-2RS	L-22	L+24	L-172	Z34 HTD 8M-35

ROLLER CODE 329617

DIA. 158/70/30 Z16 3/4"

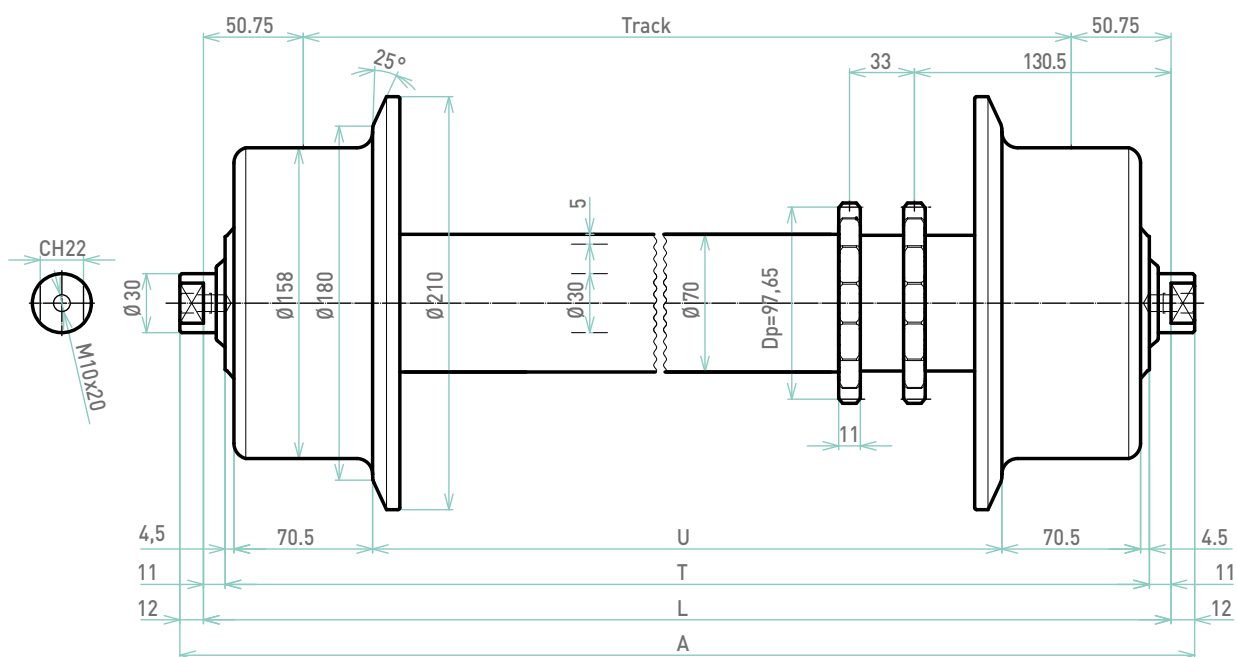

Items	Type	D	Bearing	T	A	U	Sprocket
329617	driven	158	6206-2RS	L-22	L+24	L-172	Z16 3/4"

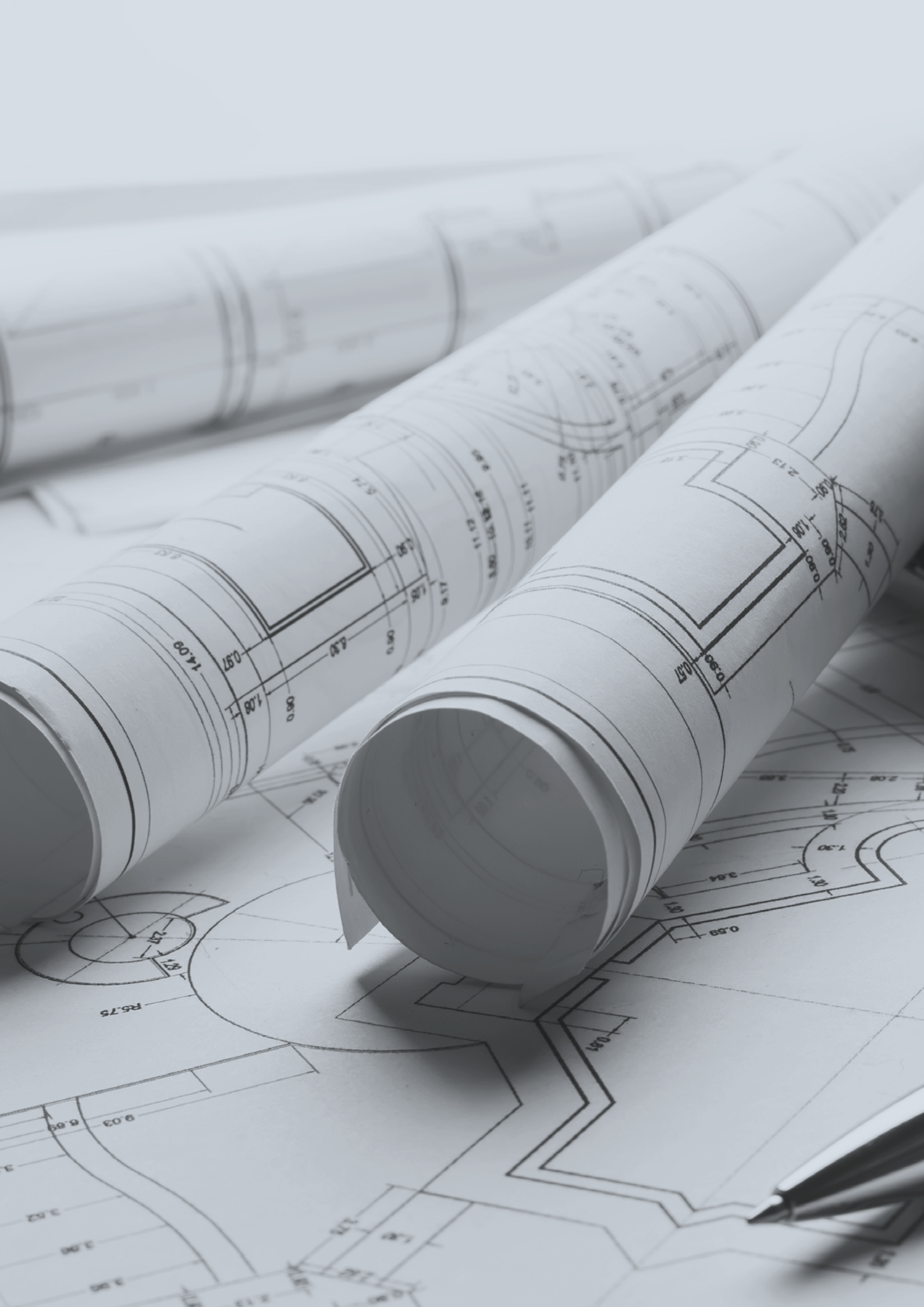

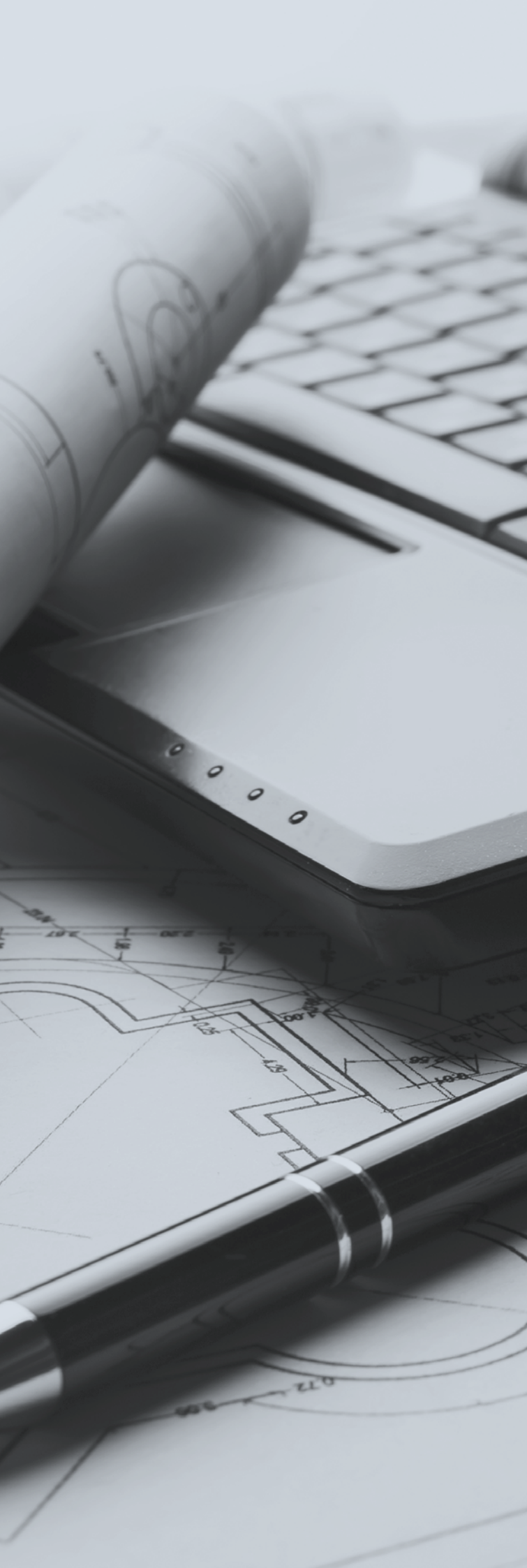

DESIGN

REQUIREMENTS FOR

OUT OF STANDARD

ROLLERS CODESIGN

Thanks to the experience achieved over many years of activity in materials handling, **DugomRulli** can cooperate with their customers in the definition phase of the product, meeting the conveyors design specifications.

The result will be better seeing as the available project data will be accurate and complete. For this reason, we ask our customers to fill in the attached technical questionnaires related to the specifications of the system, the specific size and configuration of the rollers.

Drawings and 3D models of all rollers included in this catalogue can be downloaded through DugomRulli web site.



QR Code

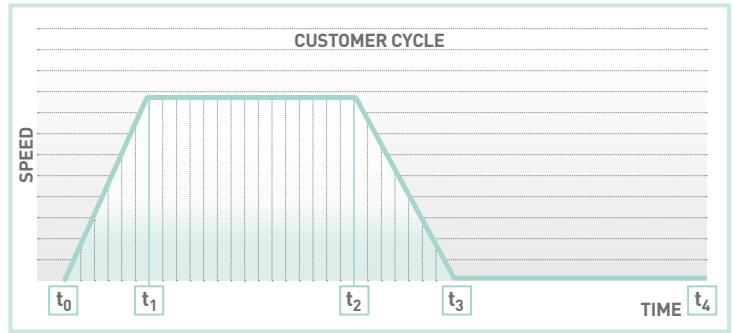

CUSTOMER CYCLE	UM	t_0-t_1	t_1-t_2	t_2-t_3	t_3-t_4
Accumulated distance	[m]				
Accumulated time	[s]				
Speed	[m/min]				
Acceleration	[m/s ²]				
Torque	[Nm]				

UNIT LOAD	
Weight	[kg]
Length	[mm]
Width	[mm]

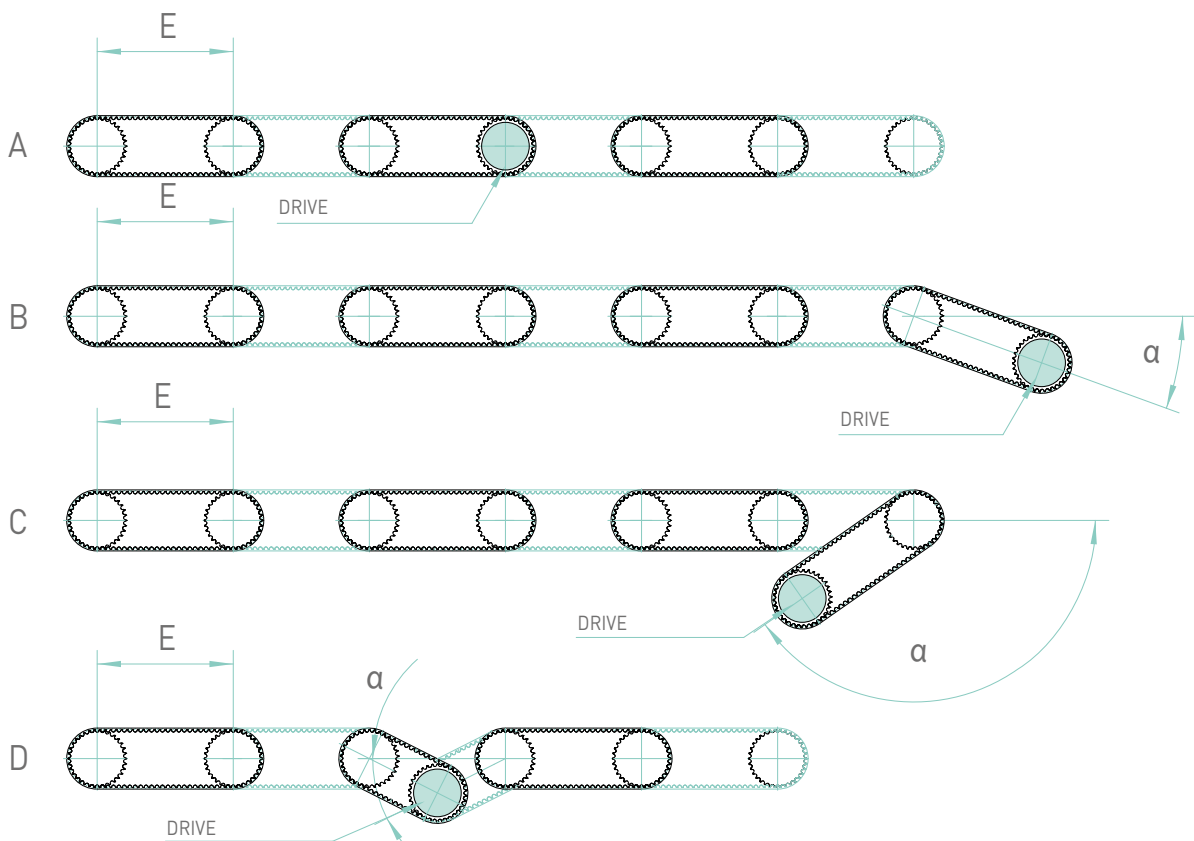

POWER ROLLER BED CONVEYOR	
Distance between the center of the rollers, E	[mm]
Friction factor (e.g. 0,035)	-
Belt tensioning between driven rollers	[N]
Belt tensioning between driven-drive rollers	[N]
Angle of the drive belt, α (see drawing)	[degrees]
Indicate which is the drive used "A, B, C, D"	-

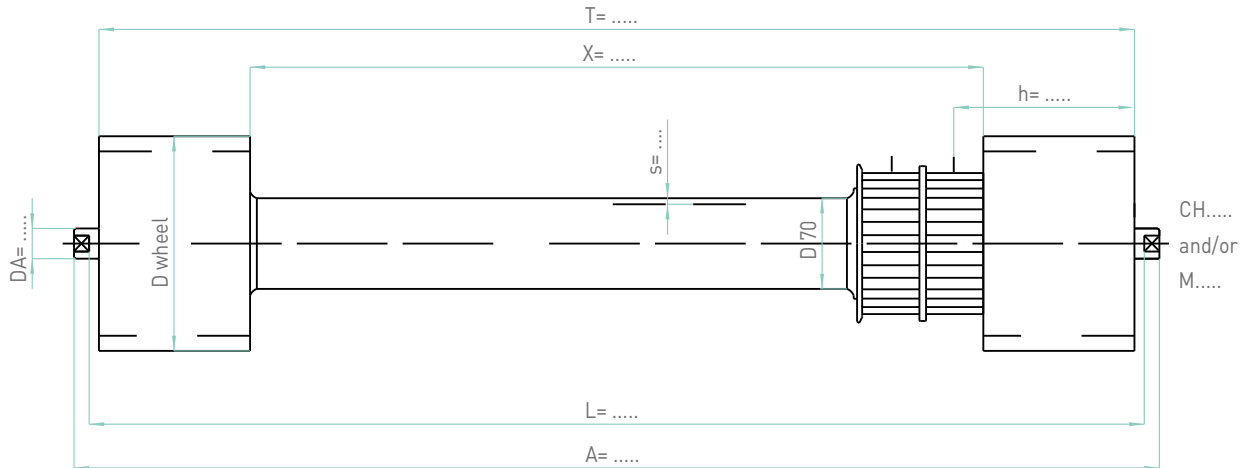



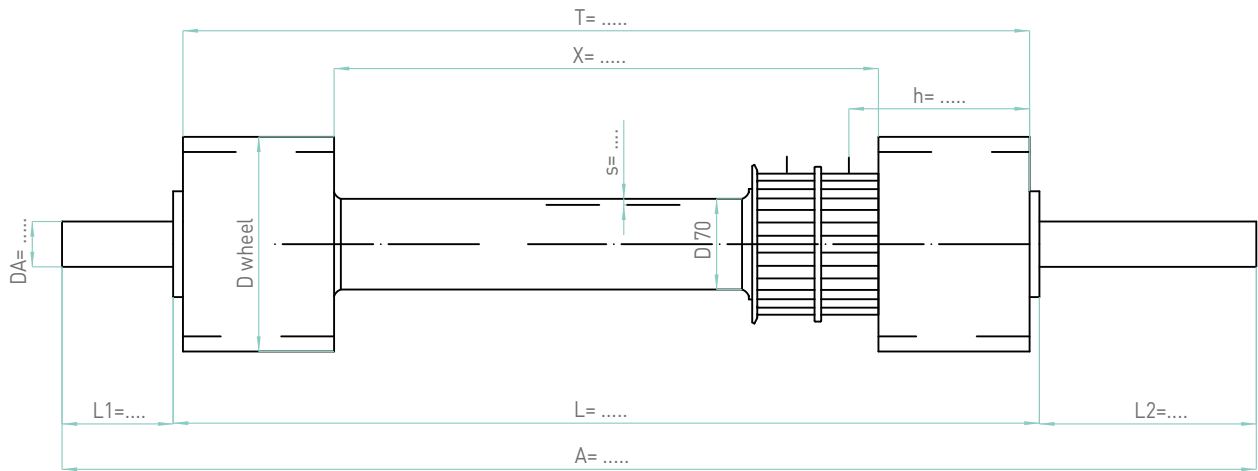

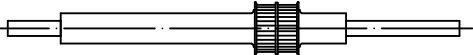
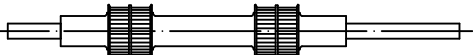
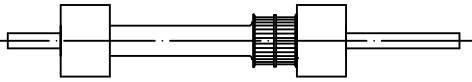
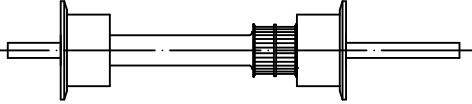
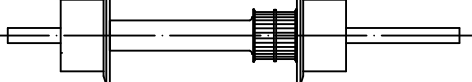
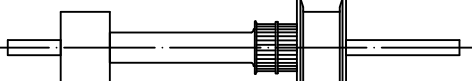
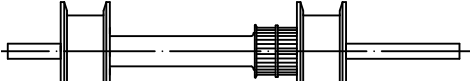
	SPROCKETS		PULLEYS		FLANGES
Type	Pitch: No. of teeth:		Z34 HTD 8M-35 Z34 HTD 8M-55 Z34 HTD-8M 90	<input type="checkbox"/> <input type="checkbox"/> <input type="checkbox"/>	
Number		<input type="checkbox"/> <input type="checkbox"/>		<input type="checkbox"/> <input type="checkbox"/>	
Positioning		<input type="checkbox"/> <input type="checkbox"/>		<input type="checkbox"/> <input type="checkbox"/>	
Flanges positioning		<input type="checkbox"/> <input type="checkbox"/>		<input type="checkbox"/> <input type="checkbox"/> <input type="checkbox"/> <input type="checkbox"/> <input type="checkbox"/>	
wheels dimension	wheel Ø 125 mm x 58 mm x 60 mm x 97 mm wheel Ø 140 mm x 70 mm x 80 mm x 105 mm wheel Ø 158 mm x 70,5 mm	<input type="checkbox"/> <input type="checkbox"/> <input type="checkbox"/> <input type="checkbox"/> <input type="checkbox"/> <input type="checkbox"/> <input type="checkbox"/>	wheel Ø 125 mm x 58 mm x 60 mm x 97 mm wheel Ø 140 mm x 70 mm x 80 mm x 105 mm wheel Ø 158 mm x 70,5 mm	<input type="checkbox"/> <input type="checkbox"/> <input type="checkbox"/> <input type="checkbox"/> <input type="checkbox"/> <input type="checkbox"/> <input type="checkbox"/>	
			Steel wheels Polyurethane coated wheels	<input type="checkbox"/> <input type="checkbox"/>	

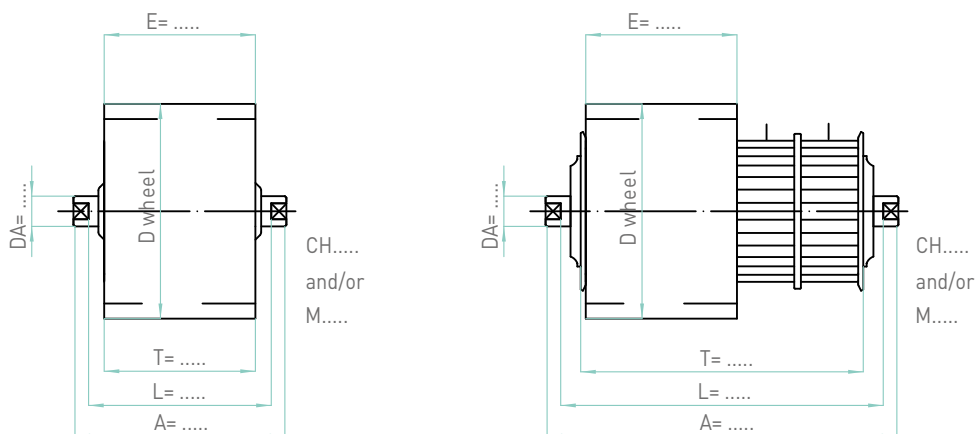

Pulley type	<input type="checkbox"/> Z34 HTD 8M-35 <input type="checkbox"/> Z34 HTD 8M-55 <input type="checkbox"/> Z34 HTD-8M 90	<input type="checkbox"/> <input type="checkbox"/> <input type="checkbox"/>	
Number of Pulleys	 	<input type="checkbox"/> <input type="checkbox"/>	
Flanges positioning	    	<input type="checkbox"/> <input type="checkbox"/> <input type="checkbox"/> <input type="checkbox"/> <input type="checkbox"/>	
wheels dimension	<input type="checkbox"/> wheel Ø 125 mm x 58 mm <input type="checkbox"/> x 60 mm <input type="checkbox"/> x 97 mm <input type="checkbox"/> wheel Ø 140 mm x 70 mm <input type="checkbox"/> x 80 mm <input type="checkbox"/> x 105 mm <input type="checkbox"/> wheel Ø 158 mm x 70,5 mm	<input type="checkbox"/> <input type="checkbox"/> <input type="checkbox"/> <input type="checkbox"/> <input type="checkbox"/> <input type="checkbox"/> <input type="checkbox"/>	<input type="checkbox"/> flange Ø 165/10° <input type="checkbox"/> flange Ø 165/35° <input type="checkbox"/> flange Ø 183/20° <input type="checkbox"/> flange Ø 190/14° <input type="checkbox"/> flange Ø 190/20° <input type="checkbox"/> hardened
	<input type="checkbox"/> Steel wheels <input type="checkbox"/> Polyurethane coated wheels	<input type="checkbox"/> <input type="checkbox"/>	

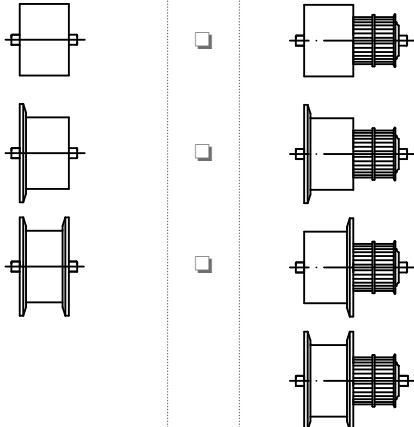

Pulley type	Z34 HTD 8M-35 <input type="checkbox"/> Z34 HTD 8M-55 <input type="checkbox"/> Z34 HTD-8M 90 <input type="checkbox"/>	
Flanges positioning		
wheels dimension	wheel Ø 125 mm x 58 mm <input type="checkbox"/> x 60 mm <input type="checkbox"/> x 97 mm <input type="checkbox"/> wheel Ø 140 mm x 70 mm <input type="checkbox"/> x 80 mm <input type="checkbox"/> x 105 mm <input type="checkbox"/>	flange Ø 165/10° <input type="checkbox"/> flange Ø 165/35° <input type="checkbox"/> flange Ø 183/20° <input type="checkbox"/> flange Ø 190/14° <input type="checkbox"/> flange Ø 190/20° <input type="checkbox"/> hardened <input type="checkbox"/>
	Steel wheels <input type="checkbox"/> Polyurethane coated wheels <input type="checkbox"/>	

ASSEMBLY TOLERANCE ON ROLLERBEDS

Correct alignment is essential for the rollers to operate properly, and their performance depends on the construction precision of the conveyors' framework and the alignment between rollerbeds.

Misalignments generate overloads on the rollers and, under these severe operating conditions, fatigue effects on rollers are accelerated.

Designers and plant manufacturers should respect the following assembly tolerance to minimize out of design conditions:

$$x_{i+1} - x_i = \pm 0.5$$

$$y_{i+1} - y_i = \text{[see note 1]}$$

$$z_{i+1} - z_i = \pm 0.5$$

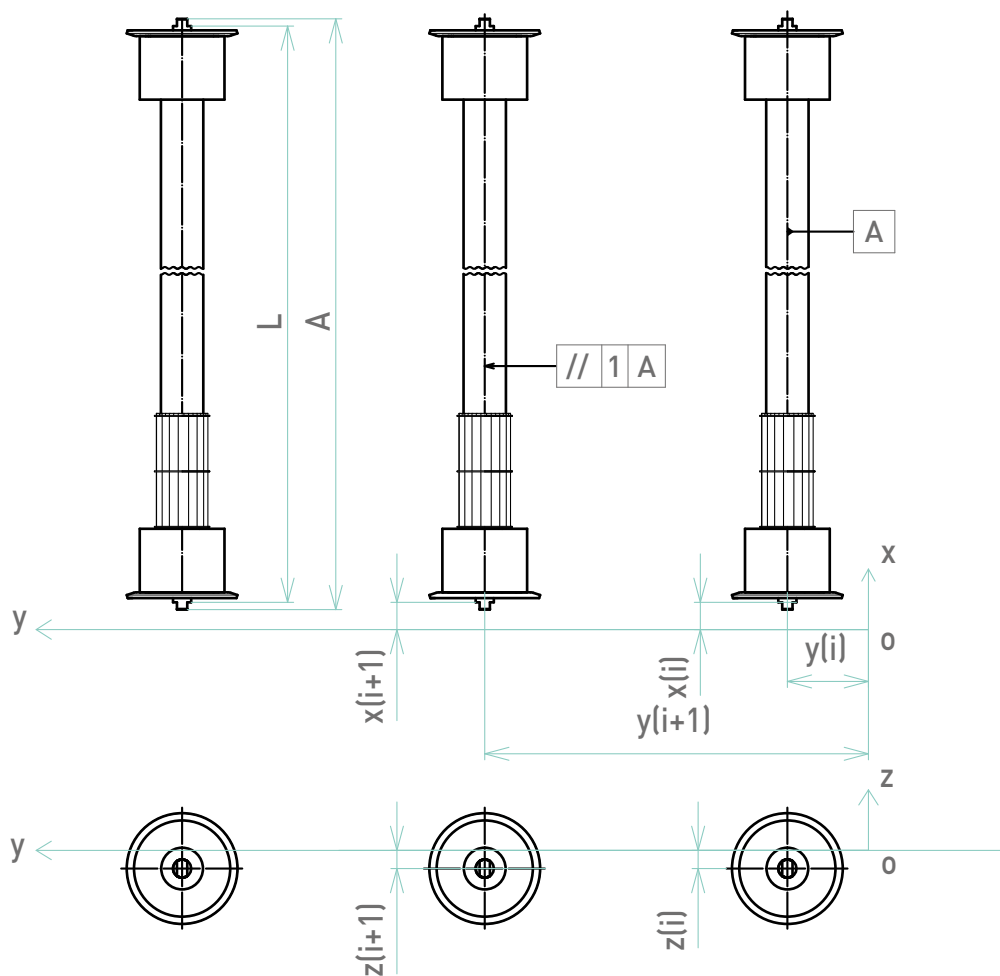

Notes:

1. The tolerance must be compatible with specification concerning belt tensioning
2. The system's designer is responsible to check the adequate clearance between the roller flange and the handled unit;
3. For safety and assembly information please consult the USE AND MAINTENANCE MANUAL available on our web site (www.dugomrulli.it).

All dimensions are subject to machining tolerances, and although drawings and illustrations are exact, they place the manufacturer under no obligation whatsoever.

Dugomrulli reserves the right to modify their products at any time without notice.

Even a part reproduction of present catalogue's illustrations, and text, is forbidden.



Codice QR



KEY REVISIONS TO CATALOGUE
CATALOGUE AU05
REV. 02/19
02 - Serial number revision
19 - Year in review

Progetto Grafico



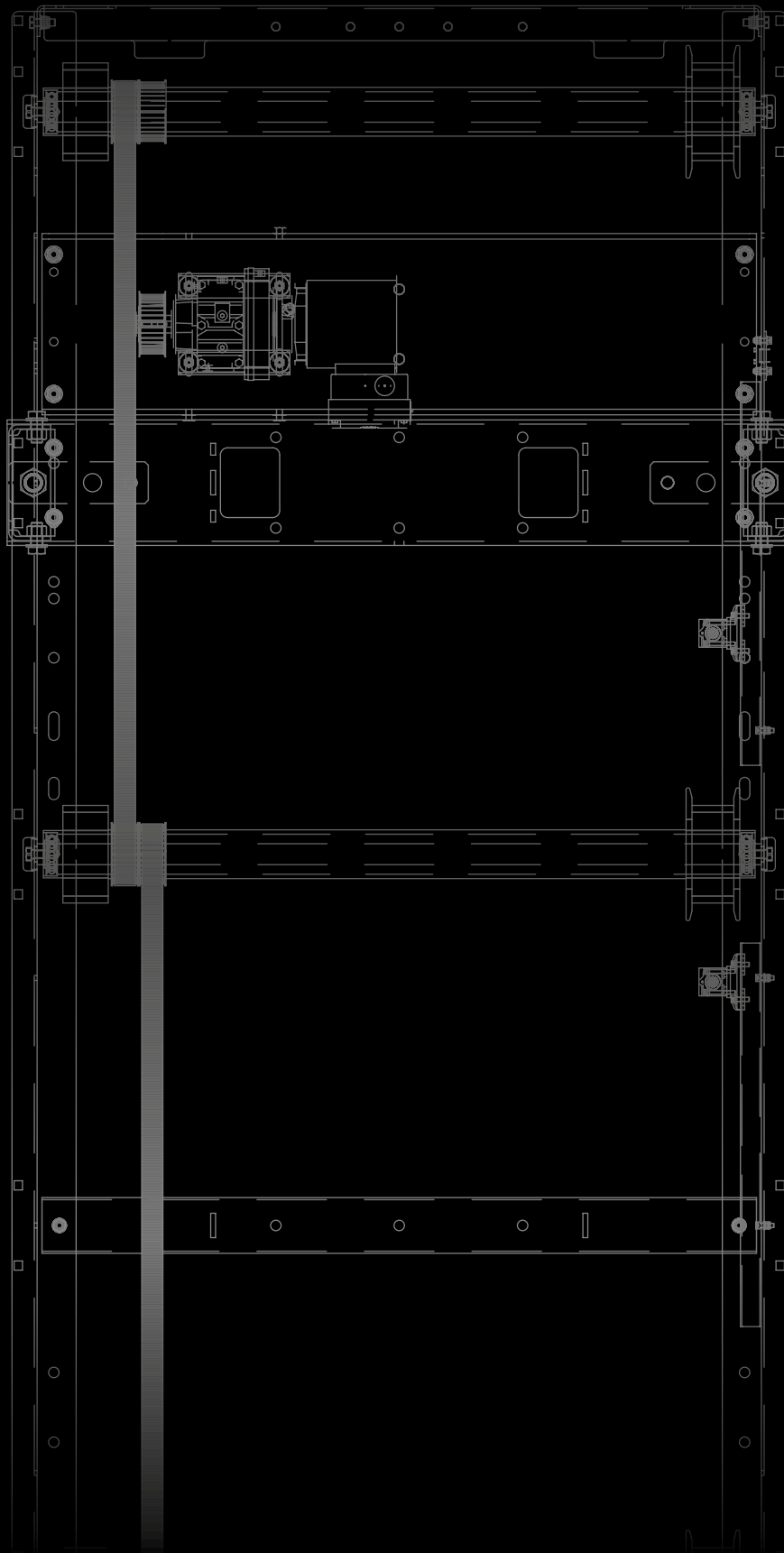

DUGOMRULLI S.p.A.

Via Ippolito Nievo, 8 | 40069 Zola Predosa (Bo) | Tel. 051.755406 | Fax 051.758989
dugom@dugomrulli.it | www.dugomrulli.it