

Catalog | March 2016

Low voltage Process performance motors

With expertise, and a comprehensive portfolio of products and life-cycle services, we help value-minded industrial customers improve their energy efficiency and productivity.

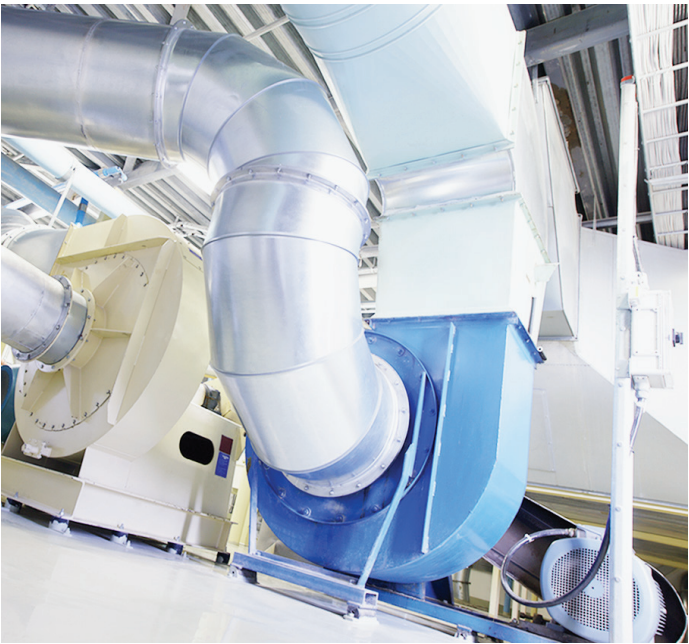

Low voltage Process performance motors

Sizes 63 to 450, 0.09 to 1000 kW

| | |
|----------------------------------------------|------------|
| General information | 4 |
| Mounting arrangements | 8 |
| Cooling | 9 |
| Degrees of protection: IP code/IK code | 10 |
| Insulation | 11 |
| Voltage and frequency | 12 |
| Surface treatment | 13 |
| Cast iron motors | 20 |
| Ordering information | 20 |
| Rating plates | 21 |
| Technical data | 22 |
| Variant codes | 38 |
| Mechanical design | 43 |
| Dimension drawings | 64 |
| Accessories | 72 |
| Cast iron motors in brief | 78 |
| Motor construction | 81 |
| Aluminum motors | 84 |
| Ordering information | 84 |
| Rating plates | 85 |
| Technical data | 86 |
| Variant codes | 95 |
| Mechanical design | 99 |
| Dimension drawings | 110 |
| Accessories | 132 |
| Aluminum motors in brief | 133 |
| Total product offering | 135 |
| Life cycle services and support | 136 |

International motor efficiency standards

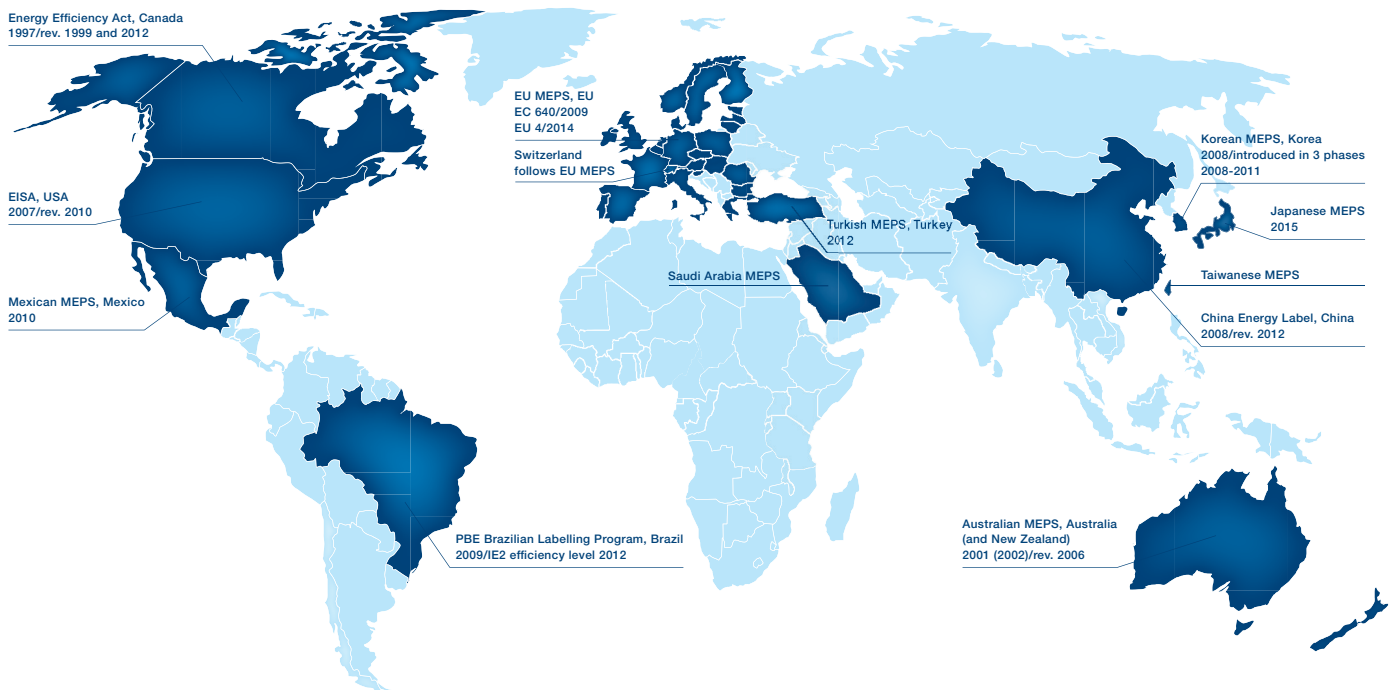

Since the validation of IEC/EN 60034-30:2008 and its refined version IEC/EN 60034-30-1: 2014, a worldwide energy efficiency classification system has existed for low voltage three-phase asynchronous motors. This system increases the level of harmonization in efficiency regulations around the world and also covers motors for explosive atmospheres. IEC/EN 60034-30-1: 2014 defines International Efficiency (IE) classes for single speed, three-phase, 50 and 60 Hz induction motors. The standard is part of an effort to unify motor testing procedures as well as efficiency and product labeling requirements to enable motor purchasers worldwide to easily recognize premium efficiency products. The efficiency levels defined in IEC/EN 60034-30-1 are based on test methods specified in IEC/EN 60034-2-1 which has been updated to edition 2.0, 2014-06.

To promote transparency in the market, IEC 60034-30 states that both the efficiency class and efficiency value must be shown on the motor rating plate and in product documentation. The documentation must clearly indicate the efficiency testing method used as the different methods can produce differing results.

Minimum energy performance standards

While the IEC sets guidelines for motor testing and efficiency classes, the organization does not regulate efficiency. The biggest drivers for mandatory Minimum Energy Performance Standard (MEPS) levels for electric motors are global climate change, government targets to cut the CO₂ emissions and rising electricity demand, especially in developing countries. The whole value chain, from manufacturer up to end user, must be aware of the legislation in order to meet local requirements and additionally save energy and reduce carbon footprint.

Harmonized standards and the increasing adoption of MEPS around the world are good news. However, it is important to remember that harmonization is an ongoing process. Even though MEPS are already in effect in several regions, they are evolving and they differ in terms of scope and requirements. At the same time, new countries are planning to adopt their own MEPS. To get the latest information please visit www.abb.com/motors&generators/energyefficiency.

IEC/EN 60034-30-1: 2014

IEC/EN 60034-30-1:2014 defines four International Efficiency (IE) classes for single speed electric motors that are rated according to IEC 60034-1 or IEC 60079-0 (explosive atmospheres) and designed for operation on sinusoidal voltage.

- IE4 = Super premium efficiency
- IE3 = Premium efficiency, identical to 'NEMA Premium' in the USA for 60 Hz
- IE2 = High efficiency, identical to EPAact in the USA for 60 Hz
- IE1 = Standard efficiency

Efficiency levels defined in IEC/EN 60034-30-1 are based on test methods specified in IEC 60034-2-1.

IEC/EN 60034-30-1 covers power range 120 W to 1000 kW. All technical constructions of electric motors are covered as long as they are rated for direct on-line operation. The coverage of the standard includes:

- Single speed electric motors (single and three-phase), 50 and 60 Hz
- 2, 4, 6 and 8 poles
- Rated output P_N from 0.12 kW to 1000 kW
- Rated voltage U_N above 50 V up to 1 kV
- Motors, capable of continuous operation at their rated power with a temperature rise within the specified insulation temperature class
- Motors, marked with any ambient temperature within the range of -20 °C to +60 °C
- Motors, marked with an altitude up to 4000 m above sea level

The following motors are excluded from IEC/EN 60034-30-1:

- Single-speed motors with 10 or more poles or multi-speed motors
- Motors completely integrated into a machine (for example, pump, fan or compressor) that cannot be tested separately from machine
- Brake motors, when the brake can not be dismantled or separately fed

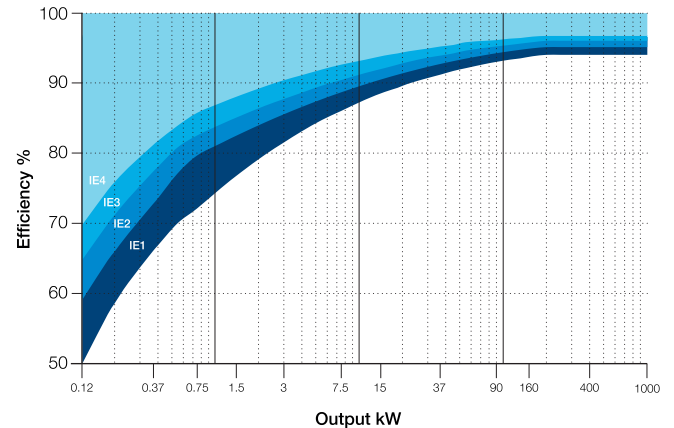

IE Classes - 4-pole motors

ABB and efficiency standards

ABB determines efficiency values according to IEC 60034-2-1 using the low uncertainty method (i.e. indirect method), with additional load losses determined by measurement.

As the world market leader, ABB offers the largest range of LV motors available. It has long advocated the need for efficiency in motors, and high efficiency products have formed the core of its portfolio for many years. The core of ABB's Process performance range is based on full range in IE2 and IE3 motors - with many available from stock. We also supply IE4 motors for additional energy savings.

Minimum efficiency values defined in IEC/EN 60034-30-1: 2014 (reference values at 50 Hz, based on test methods specified in IEC 60034-2-1 which has been updated to edition 2.0, 2014-06).

| Output kW | IE1 Standard efficiency | | | | IE2 High efficiency | | | | IE3 Premium efficiency | | | | IE4 Super Premium efficiency | | | |
|--------------|----------------------------|--------|--------|--------|------------------------|--------|--------|--------|---------------------------|--------|--------|--------|---------------------------------|--------|--------|--------|
| | 2 pole | 4 pole | 6 pole | 8 pole | 2 pole | 4 pole | 6 pole | 8 pole | 2 pole | 4 pole | 6 pole | 8 pole | 2 pole | 4 pole | 6 pole | 8 pole |
| 0.12 | 45.0 | 50.0 | 38.3 | 31.0 | 53.6 | 59.1 | 50.6 | 39.8 | 60.8 | 64.8 | 57.7 | 50.7 | 66.5 | 69.8 | 64.9 | 62.3 |
| 0.18 | 52.8 | 57.0 | 45.5 | 38.0 | 60.4 | 64.7 | 56.6 | 45.9 | 65.9 | 69.9 | 63.9 | 58.7 | 70.8 | 74.7 | 70.1 | 67.2 |
| 0.20 | 54.6 | 58.5 | 47.6 | 39.7 | 61.9 | 65.9 | 58.2 | 47.4 | 67.2 | 71.1 | 65.4 | 60.6 | 71.9 | 75.8 | 71.4 | 68.4 |
| 0.25 | 58.2 | 61.5 | 52.1 | 43.4 | 64.8 | 68.5 | 61.6 | 50.6 | 69.7 | 73.5 | 68.6 | 64.1 | 74.3 | 77.9 | 74.1 | 70.8 |
| 0.37 | 63.9 | 66.0 | 59.7 | 49.7 | 69.5 | 72.7 | 67.6 | 56.1 | 73.8 | 77.3 | 73.5 | 69.3 | 78.1 | 81.1 | 78.0 | 74.3 |
| 0.40 | 64.9 | 66.8 | 61.1 | 50.9 | 70.4 | 73.5 | 68.8 | 57.2 | 74.6 | 78.0 | 74.4 | 70.1 | 78.9 | 81.7 | 78.7 | 74.9 |
| 0.55 | 69.0 | 70.0 | 65.8 | 56.1 | 74.1 | 77.1 | 73.1 | 61.7 | 77.8 | 80.8 | 77.2 | 73.0 | 81.5 | 83.9 | 80.9 | 77.0 |
| 0.75 | 72.1 | 72.1 | 70.0 | 61.2 | 77.4 | 79.6 | 75.9 | 66.2 | 80.7 | 82.5 | 78.9 | 75.0 | 83.5 | 85.7 | 82.7 | 78.4 |
| 1.1 | 75.0 | 75.0 | 72.9 | 66.5 | 79.6 | 81.4 | 78.1 | 70.8 | 82.7 | 84.1 | 81.0 | 77.7 | 85.2 | 87.2 | 84.5 | 80.8 |
| 1.5 | 77.2 | 77.2 | 75.2 | 70.2 | 81.3 | 82.8 | 79.8 | 74.1 | 84.2 | 85.3 | 82.5 | 79.7 | 86.5 | 88.2 | 85.9 | 82.6 |
| 2.2 | 79.7 | 79.7 | 77.7 | 74.2 | 83.2 | 84.3 | 81.8 | 77.6 | 85.9 | 86.7 | 84.3 | 81.9 | 88.0 | 89.5 | 87.4 | 84.5 |
| 3 | 81.5 | 81.5 | 79.7 | 77.0 | 84.6 | 85.5 | 83.3 | 80.0 | 87.1 | 87.7 | 85.6 | 83.5 | 89.1 | 90.4 | 88.6 | 85.9 |
| 4 | 83.1 | 83.1 | 81.4 | 79.2 | 85.8 | 86.6 | 84.6 | 81.9 | 88.1 | 88.6 | 86.8 | 84.8 | 90.0 | 91.1 | 89.5 | 87.1 |
| 5.5 | 84.7 | 84.7 | 83.1 | 81.4 | 87.0 | 87.7 | 86.0 | 83.8 | 89.2 | 89.6 | 88.0 | 86.2 | 90.9 | 91.9 | 90.5 | 88.3 |
| 7.5 | 86.0 | 86.0 | 84.7 | 83.1 | 88.1 | 88.7 | 87.2 | 85.3 | 90.1 | 90.4 | 89.1 | 87.3 | 91.7 | 92.6 | 91.3 | 89.3 |
| 11 | 87.6 | 87.6 | 86.4 | 85.0 | 89.4 | 89.8 | 88.7 | 86.9 | 91.2 | 91.4 | 90.3 | 88.6 | 92.6 | 93.3 | 92.3 | 90.4 |
| 15 | 88.7 | 88.7 | 87.7 | 86.2 | 90.3 | 90.6 | 89.7 | 88.0 | 91.9 | 92.1 | 91.2 | 89.6 | 93.3 | 93.9 | 92.9 | 91.2 |
| 18.5 | 89.3 | 89.3 | 88.6 | 86.9 | 90.9 | 91.2 | 90.4 | 88.6 | 92.4 | 92.6 | 91.7 | 90.1 | 93.7 | 94.2 | 93.4 | 91.7 |
| 22 | 89.9 | 89.9 | 89.2 | 87.4 | 91.3 | 91.6 | 90.9 | 89.1 | 92.7 | 93.0 | 92.2 | 90.6 | 94.0 | 94.5 | 93.7 | 92.1 |
| 30 | 90.7 | 90.7 | 90.2 | 88.3 | 92.0 | 92.3 | 91.7 | 89.8 | 93.3 | 93.6 | 92.9 | 91.3 | 94.5 | 94.9 | 94.2 | 92.7 |
| 37 | 91.2 | 91.2 | 90.8 | 88.8 | 92.5 | 92.7 | 92.2 | 90.3 | 93.7 | 93.9 | 93.3 | 91.8 | 94.8 | 95.2 | 94.5 | 93.1 |
| 45 | 91.7 | 91.7 | 91.4 | 89.2 | 92.9 | 93.1 | 92.7 | 90.7 | 94.0 | 94.2 | 93.7 | 92.2 | 95.0 | 95.4 | 94.8 | 93.4 |
| 55 | 92.1 | 92.1 | 91.9 | 89.7 | 93.2 | 93.5 | 93.1 | 91.0 | 94.3 | 94.6 | 94.1 | 92.5 | 95.3 | 95.7 | 95.1 | 93.7 |
| 75 | 92.7 | 92.7 | 92.6 | 90.3 | 93.8 | 94.0 | 93.7 | 91.6 | 94.7 | 95.0 | 94.6 | 93.1 | 95.6 | 96.0 | 95.4 | 94.2 |
| 90 | 93.0 | 93.0 | 92.9 | 90.7 | 94.1 | 94.2 | 94.0 | 91.9 | 95.0 | 95.2 | 94.9 | 93.4 | 95.8 | 96.1 | 95.6 | 94.4 |
| 110 | 93.3 | 93.3 | 93.3 | 91.1 | 94.3 | 94.5 | 94.3 | 92.3 | 95.2 | 95.4 | 95.1 | 93.7 | 96.0 | 96.3 | 95.8 | 94.7 |
| 132 | 93.5 | 93.5 | 93.5 | 91.5 | 94.6 | 94.7 | 94.6 | 92.6 | 95.4 | 95.6 | 95.4 | 94.0 | 96.2 | 96.4 | 96.0 | 94.9 |
| 160 | 93.8 | 93.8 | 93.8 | 91.9 | 94.8 | 94.9 | 94.8 | 93.0 | 95.6 | 95.8 | 95.6 | 94.3 | 96.3 | 96.6 | 96.2 | 95.1 |
| 200 | 94.0 | 94.0 | 94.0 | 92.5 | 95.0 | 95.1 | 95.0 | 93.5 | 95.8 | 96.0 | 95.8 | 94.6 | 96.5 | 96.7 | 96.3 | 95.4 |
| 250 | 94.0 | 94.0 | 94.0 | 92.5 | 95.0 | 95.1 | 95.0 | 93.5 | 95.8 | 96.0 | 95.8 | 94.6 | 96.5 | 96.7 | 96.5 | 95.4 |
| 315 | 94.0 | 94.0 | 94.0 | 92.5 | 95.0 | 95.1 | 95.0 | 93.5 | 95.8 | 96.0 | 95.8 | 94.6 | 96.5 | 96.7 | 96.6 | 95.4 |
| 355 | 94.0 | 94.0 | 94.0 | 92.5 | 95.0 | 95.1 | 95.0 | 93.5 | 95.8 | 96.0 | 95.8 | 94.6 | 96.5 | 96.7 | 96.6 | 95.4 |
| 400 | 94.0 | 94.0 | 94.0 | 92.5 | 95.0 | 95.1 | 95.0 | 93.5 | 95.8 | 96.0 | 95.8 | 94.6 | 96.5 | 96.7 | 96.6 | 95.4 |
| 450 | 94.0 | 94.0 | 94.0 | 92.5 | 95.0 | 95.1 | 95.0 | 93.5 | 95.8 | 96.0 | 95.8 | 94.6 | 96.5 | 96.7 | 96.6 | 95.4 |
| 500-1000 | 94.0 | 94.0 | 94.0 | 92.5 | 95.0 | 95.1 | 95.0 | 93.5 | 95.8 | 96.0 | 95.8 | 94.6 | 96.5 | 96.7 | 96.6 | 95.4 |

EU MEPS – Efficiency requirements for low voltage motors in Europe

Mandatory MEPS requirements

EU MEPS (European Minimum Energy Performance Standard) sets mandatory minimum efficiency levels for electric motors introduced into the European market. It is based on European Commission Regulation EC 640/2009 and an amendment passed in 2014, Regulation EU 4/2014.

MEPS scope

The MEPS scheme covers 2-, 4- and 6-pole single speed, three-phase induction motors in a power range 0.75 to 375 kW, rated up to 1000 V on the basis of continuous duty operation. The scheme is being implemented in three stages:

- Stage 1: 16 June 2011: Motors must meet the IE2 efficiency level
- Stage 2: 1 January 2015: Motors with a rated output of 7.5 - 375 kW must meet EITHER the IE3 efficiency level if driven direct-on-line OR the IE2 level if fitted with a variable speed drive
- Stage 3: 1 January 2017: Motors with a rated output of 0.75 - 375 kW must meet EITHER the IE3 efficiency level if driven direct-on-line OR the IE2 level if fitted with a variable speed drive

The amendment (Regulation EU 4/2014) did not change the scope of EU MEPS but it did change the details concerning which motors are excluded.

Efficiency testing methods

Motor losses and efficiency values in the EU MEPS scheme must be determined using the methods specified in standard IEC 60034-2-1:06-2014. International efficiency classes (IE4, IE3, IE2 and IE1) are defined in standard IEC 60034-30-1.

Compulsory efficiency levels

The table of minimum efficiency values on the previous page shows values according to IEC 60034-30-1:2014. Please note that this standard covers a wider range of motors than EU MEPS, which is still based on the previous standard (IEC 60034-30). Specifically, EU MEPS does not apply to 8-pole motors, or to motors rated below 0.75 or above 375 kW. IE1 motors have been excluded from the European market since EU MEPS came into force on 16 June 2011. Regulation EC 640/2009 required the following information on the motor rating plate and in motor documentation:

- Lowest nominal efficiency at 100%, 75% and 50% rated load
- Efficiency level (IE2, IE3 or IE4)
- Year of manufacture

These requirements were relaxed by amendment EU 4/2014 for small motors where the rating plate is too small to accommodate the full set of figures. In such cases manufacturers are now allowed to show only the efficiency for 100% rated load.

ABB and EU MEPS

At ABB we have long spoken out in favor of efforts to boost energy efficiency and reduce emissions. We play an active role in organizations that set efficiency standards, and we are happy to see MEPS being adopted in more and more countries around the world. We hope the authorities will maintain the momentum and take MEPS forward. IEC standards move fast, and active work is needed to bring the scope of EU MEPS into line with IEC/EN 60034-30-1. EU MEPS has an important role to play in helping European industry to maintain and grow its competitiveness.

Markings and documentation



From January 1st 2015 the stage 2 requirements for EU MEPS allow IE2 motors to be used only when they are fed by a VSD. These motors (7,5-375kW) must be marked so that the compulsory need to be used with a drive becomes evident. ABB uses the following stickers for the marking.

General information

Mounting arrangements

Foot-mounted motor

Code I / code II

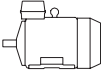
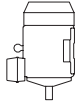
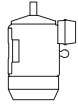
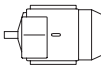
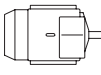
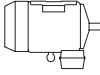
| | | | | | | |
|-----------------------------------------------------------------------------------|-----------------------------------------------------------------------------------|-----------------------------------------------------------------------------------|-----------------------------------------------------------------------------------|-----------------------------------------------------------------------------------|------------------------------------------------------------------------------------|--------------------------------------------------------------------------------------------------------------------------------|
|  |  |  |  |  |  | Product code pos. 12 A: foot-mounted, term.box top R: foot-mounted, term.box RHS L: foot-mounted, term.box LHS |
| IM B3 IM 1001 | IM V5 IM 1011 | IM V6 IM 1031 | IM B6 IM 1051 | IM B7 IM 1061 | IM B8 IM 1071 | |

Flange-mounted motor, large flange

Code I / code II

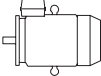
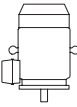
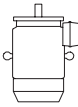
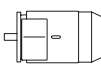
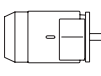
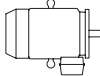
| | | | | | | |
|-----------------------------------------------------------------------------------|-----------------------------------------------------------------------------------|-----------------------------------------------------------------------------------|-----------------------------------------------------------------------------------|-----------------------------------------------------------------------------------|------------------------------------------------------------------------------------|----------------------------------------------------------------|
|  |  |  |  |  |  | Product code pos. 12 B: flange mounted, large flange |
| IM B5 IM 3001 | IM V1 IM 3011 | IM V3 IM 3031 | *) IM 3051 | *) IM 3061 | *) IM 3071 | |

Flange-mounted motor, small flange

Code I / code II

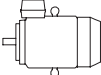
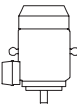
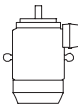
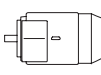
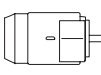
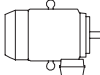
| | | | | | | |
|-----------------------------------------------------------------------------------|-----------------------------------------------------------------------------------|-----------------------------------------------------------------------------------|-----------------------------------------------------------------------------------|-----------------------------------------------------------------------------------|------------------------------------------------------------------------------------|----------------------------------------------------------------|
|  |  |  |  |  |  | Product code pos. 12 C: flange mounted, small flange |
| IM B14 IM 3601 | IM V18 IM 3611 | IM V19 IM 3631 | *) IM 3651 | *) IM 3661 | *) IM 3671 | |

Foot- and flange-mounted motor with feet, large flange

Code I / code II

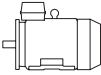
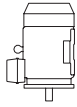
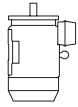
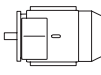
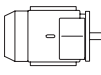
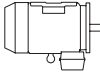
| | | | | | | |
|-------------------------------------------------------------------------------------|-------------------------------------------------------------------------------------|-------------------------------------------------------------------------------------|-------------------------------------------------------------------------------------|-------------------------------------------------------------------------------------|--------------------------------------------------------------------------------------|--------------------------------------------------------------------------------------------------------------------------------------------------------|
|  |  |  |  |  |  | Product code pos. 12 H: foot/flange-mounted, term. box top S: foot/flange-mounted, term. box RHS T: foot/flange-mounted, term. box LHS |
| IM B35 IM 2001 | IM V15 IM 2011 | IM V35 IM 2031 | *) IM 2051 | *) IM 2061 | *) IM 2071 | |

Foot- and flange-mounted motor with feet, small flange

Code I / code II

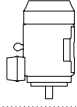
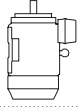
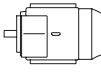
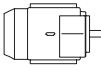
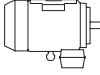
| | | | | | | |
|-------------------------------------------------------------------------------------|-------------------------------------------------------------------------------------|-------------------------------------------------------------------------------------|-------------------------------------------------------------------------------------|-------------------------------------------------------------------------------------|--------------------------------------------------------------------------------------|---------------------------------------------------------------------|
|  |  |  |  |  |  | Product code pos. 12 J: foot/flange-mounted, small flange |
| IM B34 IM 2101 | IM V17 IM 2111 | IM V18 IM 2131 | IM 2151 | IM 2161 | IM 2171 | |

Foot-mounted motor, shaft with free extensions

Code I / code II

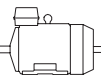
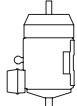
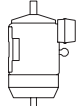
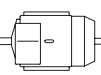
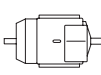
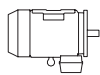
| | | | | | | |
|-------------------------------------------------------------------------------------|-------------------------------------------------------------------------------------|-------------------------------------------------------------------------------------|-------------------------------------------------------------------------------------|-------------------------------------------------------------------------------------|--------------------------------------------------------------------------------------|-----------------------------|
|  |  |  |  |  |  | Product code pos. 12 |
| IM 1002 | IM 1012 | IM 1032 | IM 1052 | IM 1062 | IM 1072 | |

*) Not stated in IEC 60034-7.

Note: If the motor is mounted shaft upwards, take measures to prevent water or any other liquid from running down the shaft into the motor.

General information

Cooling

Designation system concerning methods of cooling refers to standard IEC 60034-6.

Explanation of the product code

| International Cooling | Circuit arrangement | Primary coolant | Method of movement of primary coolant | Secondary coolant | Method of movement of secondary coolant |
|-----------------------|---------------------|-----------------|---------------------------------------|-------------------|-----------------------------------------|
| IC | 4 | (A) | 1 | (A) | 6 |
| | 1 | 2 | 3 | 4 | 5 |

Position 1

| | |
|----|---------------------------------|
| 0: | Free circulation (open circuit) |
| 4: | Free circulation (open circuit) |

Position 2

| | |
|----|----------------------------------------------|
| A: | For air (omitted for simplified designation) |
|----|----------------------------------------------|

Position 3

| | |
|----|---------------------------------------|
| 0: | Free convection |
| 1: | Self-circulation |
| 6: | Machine-mounted independent component |

Position 4

| | |
|----|----------------------------------------------|
| A: | For air (omitted for simplified designation) |
| W: | For water |

Position 5

| | |
|----|---------------------------------------|
| 0: | Free convection |
| 1: | Self-circulation |
| 6: | Machine-mounted independent component |
| 8: | Relative displacement |

General information

Degrees of protection: IP code/IK code

Classification of degrees of protection provided by enclosures of rotating machines refers to:

- Standard IEC 60034-5 or EN 60529 for IP code
- Standard EN 50102 for IK code

IP protection

Protection of persons against getting in contact with (or approaching) live parts and against contact with moving parts inside the enclosure. Also protection of the machine against ingress of solid foreign objects. Protection of machines against the harmful effects due to the ingress of water.

Explanation of the IP code

| Ingress protection | Degree of protection to persons and to parts of the motors inside the enclosure | Degree of protection provided by the enclosure with respect to harmful effects due to ingress of water |
|--------------------|---------------------------------------------------------------------------------|--------------------------------------------------------------------------------------------------------|
| IP | 5 | 5 |
| | 1 | 2 |

Position 1

| | |
|----|-----------------------------------------------------------|
| 2: | Motors protected against solid objects greater than 12 mm |
| 4: | Motors protected against solid objects greater than 1 mm |
| 5: | Dust-protected motors |
| 6: | Dust-tight motors |

Position 2

| | |
|----|------------------------------------------|
| 3: | Motors protected against spraying water |
| 4: | Motors protected against splashing water |
| 5: | Motors protected against water jets |
| 6: | Motors protected against heavy seas |

IK code

Classification of degrees of protection provided by enclosure for motors against external mechanical impacts.

Explanation of the IK code

| International mechanical protection | Characteristic group |
|-------------------------------------|----------------------|
| IK | 08 |
| | 1 |

Position 1

Relation between IK code and impact energy:

| IK code | Impact energy/Joule |
|---------|-------------------------------------|
| 0: | Not protected according to EN 50102 |
| 01: | 0.15 |
| 02: | 0.2 |
| 03: | 0.35 |
| 04: | 0.5 |
| 05: | 0.7 |
| 06: | 1 |
| 07: | 2 |
| 08: | 5 (ABB Standard) |
| 09: | 10 |
| 10: | 20 |

General information

Insulation

ABB uses class F insulation, which, with temperature rise B, is the most common requirement among industry today.

The use of class F insulation with class B temperature rise gives ABB products a 25 °C safety margin. This can be used to increase the loading for limited periods, to operate at higher ambient temperatures or altitudes, or with greater voltage and frequency tolerances. It can also be used to extend insulation life. For instance, a 10 K temperature reduction will extend the insulation life.

Thermal class 130 (B)

- Nominal ambient temperature 40 °C
- Max permissible temperature rise 80 K
- Hot spot temperature margin 10 K

Thermal class 155 (F)

- Nominal ambient temperature 40 °C
- Max permissible temperature rise 105 K
- Hot spot temperature margin 10 K

Thermal class 180 (H)

- Nominal ambient temperature 40 °C
- Max permissible temperature rise 125 K
- Hot spot temperature margin 10 K

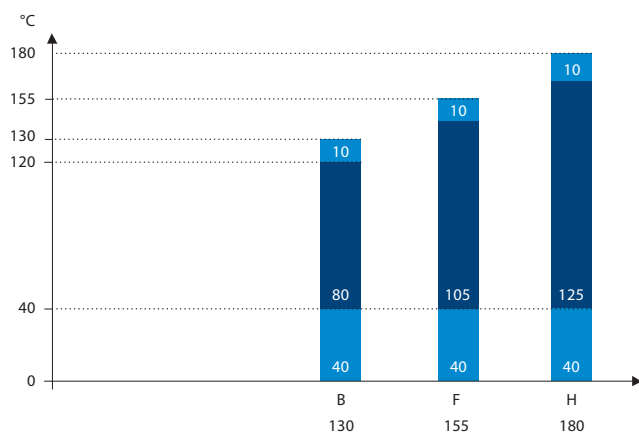

Safety margins per thermal class

General information

Voltage and frequency

The impact on temperature rise caused by voltage and frequency fluctuation is defined in IEC 60034-1. The standard divides the combinations into two zones, A and B. Zone A is the combination of voltage deviation of +/-5 % and frequency deviation of +/-2 %. Zone B is the combination of voltage deviation of +/-10 % and frequency deviation of +/-3%. This is illustrated in figure below.

Motors are capable of supplying the rated torque in both zones A and B, but the temperature rise will be higher than at rated voltage and frequency. Motors can be run in zone B only for a short period of time.

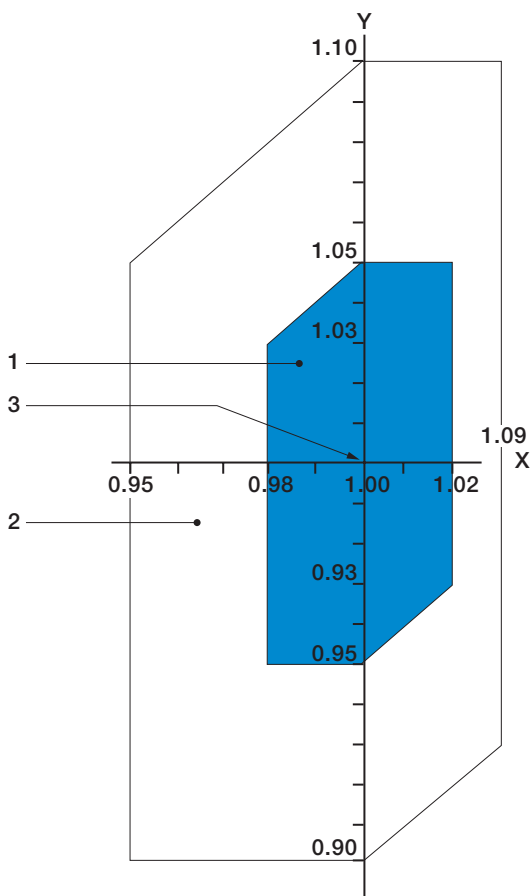

Figure Voltage and frequency deviation in zones A and B.

| Key | |
|--------|-------------------------|
| X axis | frequency p.u. |
| Y axis | voltage p.u. |
| 1 | zone A |
| 2 | zone B (outside zone A) |
| 3 | rating point |

General information

Surface treatment

The surface treatment categorization of ABB motors is based on the ISO 12944 standard. ISO 12944-5 divides paint system durability into three categories: low (L), medium (M), and high (H). Low durability corresponds to a lifetime of 2 - 5 years, medium to 5 – 15 years, and high durability to over 15 years.

The durability range is not a guaranteed lifetime. Its purpose is to help the owner of the motor plan for appropriate maintenance intervals. More frequent maintenance may be required because of fading, chalking, contamination, wear and tear, or for other reasons.

ABB's standard surface treatment is corrosivity category C3, durability range M (which equal to medium corrosivity and medium durability). Special surface treatment is available in corrosivity categories C4 and C5-M, durability class M for both. In addition, surface treatment according to the NORSOK standard for offshore environments is available as an option.

The standard ABB paint color for motors is Munsell blue 8B 4.5/3.25.

| Corrosivity category | Outdoor atmospheres | Indoor atmospheres | Use in ABB motors |
|------------------------------|-------------------------------------------------------------------------------------------------------|--------------------------------------------------------------------------------------------------------------------|----------------------------------------------------------------|
| C1, very low | Not used | Heated buildings with clean atmospheres | Not available |
| C2, low | Atmospheres with low level pollution, mostly rural areas. | Unheated buildings where condensation may occur, such as depots and sports halls. | Not available |
| C3, medium | Urban and industrial atmospheres, moderate sulfur dioxide pollution. Coastal areas with low salinity. | Production rooms with high humidity and some air pollution; food processing plants, laundries, breweries, dairies. | Standard treatment |
| C4, high | Industrial areas and coastal areas with moderate salinity. | Chemical plants, swimming pools, coastal ship- and boatyards. | Optional treatment for cast iron motors, variant code 115 |
| C5-I, very high (industrial) | Industrial areas and coastal areas with high humidity and aggressive atmosphere. | Buildings or areas with nearly permanent condensation and high pollution. | Not available |
| C5-M, very high (marine) | Coastal and offshore areas with high salinity. | Buildings or areas with nearly permanent condensation and high pollution. | Optional treatment for cast iron motors, variant code 754, 711 |

Atmospheric corrosivity categories and recommended environments.

Variable speed drives with Process performance motors

Squirrel cage induction motors offer excellent availability, reliability and efficiency. With a variable speed drive (VSD) – a frequency converter – the motor performance can be further improved. Instead of running the motor continuously at full speed, the VSD enables speed adjustment according to actual need. The VSD makes it possible to control the process accurately and in some cases even to improve the capacity of the process by operating at higher than nominal speeds.

In contrast with conventional applications operating with a direct-on-line (DOL) supply, a VSD makes smooth starting possible. This significantly reduces the stress on the motor and driven application. Smooth starting also means that the supply network will not be affected by high starting current transients, a fact that can be taken into account in the design of the network.

The use of ABB industrial drives eg. ABB 800, 880 together with Process performance motors provide substantial energy savings as the speed and therefore the power required by the process can be optimised. By choosing an ABB motor-drive package end-users can be confident that the motor and drive combination is optimised for their application; It is a working package with known performance as combination have been tested and verified.

Process performance motors are designed for both DOL and variable speed operation. A wide range of options is available, so motors can be adapted to the most demanding applications.

When selecting Process performance motors for VSDs, the following points must be taken into consideration.

1. Dimensioning

The voltage (or current) fed by the VSD is not purely sinusoidal. This may increase motor losses, vibration, and noise level. Further, a change in the distribution of losses may affect the motor's temperature rise. In each case, the motor must be correctly sized according to the instructions supplied for the frequency converter.

ABB's DriveSize program utilizes dimensioning rules that are based on comprehensive motor and drive type tests. Please use DriveSize for selecting the correct motor and drive combination for a desired load profile.

In case of manual dimensioning, note that the loadability (or load capacity) curves provided in this catalog and in the respective manuals are indicative only. Values for a specific motor and drive are available on request.

In addition to thermal dimensioning, an adequate torque margin must be maintained for stability. The maximum torque of the motor must be at least 30 % higher than the load torque over the whole duty range. Voltage drop in the supply cable must also be

taken into consideration, especially in cases where long supply cables are needed.

2. Operating speed, vibrations and shaft seals

Process performance motors are designed to work over a wide speed range and also at significantly higher than nominal speeds. The maximum speeds can be found on motor rating plates or in DriveSize. In addition to motor speed, make sure that the maximum or critical speed of the entire application is not exceeded.

If a particularly low level of vibration is required, motors with improved balancing (variant code 417) should be used.

In high speed applications, the use of labyrinth seals (variant code 783) instead of V rings should be considered.

Guideline maximum speed values for Process performance motors are shown in Table 1.

| Motor size | Maximum speed, r/min | |
|-----------------|----------------------|---------------|
| | 2-pole motors | 4-pole motors |
| 71-80 | 6000 | 4000 |
| 90-100 | 6000 | 6000 |
| 112-200 | 4500 | 4500 |
| 225-250 | 3600 | 3600 |
| 280 | 3600 | 2000 |
| 315 | 3600 | 2200 |
| 355 SM, ML, LKA | 3600 | 2200 |
| 355 LKB | 3000 | 2200 |
| 400 | 3600 | 2200 |
| 450 | 3000 | 2200 |

Table 1. Guideline maximum speed values for Process performance cast iron motors.

3. Ventilation

When the motor is operated at low speeds, the cooling capacity of the fan decreases, which again reduces the motor's load capacity. A separate constant speed fan (variant codes 183, 422, 514) can be used to increase cooling capacity.

At high speeds, the use of metal fans (variant code 068) instead of plastic ones should be considered. If a low noise level is required, unidirectional low-noise fans (variant codes 044 and 045) are recommended

4. Lubrication

In variable speed applications, bearing temperature varies as a function of speed and motor load. In such cases, the most accurate relubrication intervals can be obtained by measuring the bearing temperature under normal operating conditions. If the measured temperature is higher than +80 °C, the relubrication intervals specified on the lubrication plate or in the maintenance manual must be shortened, or lubricants suitable for high operating temperatures must be used. See ABB low voltage motor manual.

In case of continuous operation at very low speeds and at very low temperatures (below -20 °C), the lubrication properties of standard greases may not be sufficient, and special greases with additives are needed.

Operating temperatures also affect bearing life. When motors are equipped with sealed bearings, that is, bearings greased for life, it must be noted that if the operating temperature differs from the design temperature, the bearing life will also be different. More information on bearing lifetimes can be found in section Mechanical design of this catalog and in the relevant manuals.

The use of so-called conductive greases for elimination of bearing currents is not recommended because of their poor lubrication characteristics and low conductivity.

5. Winding insulation

To ensure that motors operate reliably, the effects of non-sinusoidal output voltages from the converter must be taken into consideration when selecting the correct insulation system for the motor and output filters for the converter.

Insulation and filters must be selected according to Table 2.

Winding insulation and filters required

| | |
|-------------------------------------------------|------------------------------------------------------------------------------|
| $U_N \leq 500$ V | Standard insulation |
| $U_N \leq 600$ V | Standard insulation + dU/dt filters OR Special insulation (variant code 405) |
| $U_N \leq 690$ V | Special insulation (variant code 405) AND dU/dt-filters at converter output |
| 600 V < $U_N \leq 690$ V cable length > 150 m | Special insulation (variant code 405) |

Table 2. Selection of motor winding insulation and converter output filters

For more information on dU/dt filters, see the relevant ABB drives catalogs.

For other converters and cases where the guidelines shown in Table 2 cannot be applied, selection must be based on the voltages present at motor terminals.

The allowed phase-to-ground voltage peaks at motor terminals:

- 1300 V peak: standard insulation
- 1800 V peak: special insulation, variant code 405

The maximum allowed phase-to-phase voltage peaks at the motor terminals as a function of pulse rise time are shown in Figure 1. The higher curve, Special insulation, applies to motors with special winding insulation for frequency converter supply, variant code 405. Standard insulation applies to motors with standard design

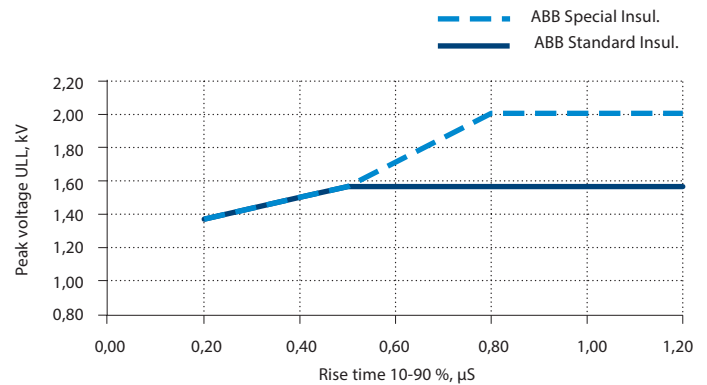

Figure 1. Maximum allowed phase-to-phase voltage peaks at motor terminals, as a function pulse rise time

6. Bearing currents

Bearing voltages and currents must be avoided in all motors to ensure reliable operation of the entire application. With drives and uncontrolled DC voltage, insulated bearings (variant code 701) and/or properly dimensioned filters at the converter must be used, as indicated in Table 3. For information on other converter types, contact ABB Sales. When ordering, clearly state which alternative will be used.

| Nominal power (P_N and / or Frame size (IEC)) | Precautionary measures |
|---------------------------------------------------------------|-------------------------------------------------------------------------|
| $P_N < 100$ kW | No action needed |
| $P_N \geq 100$ kW OR IEC 315 \leq Frame size \leq IEC 355 | Insulated non-drive end bearing |
| $P_N \geq 350$ kW OR IEC 400 \leq Frame size \leq IEC 450 | Insulated non-drive end bearing AND Common mode filter at the converter |

Table 3. Precautionary measures to avoid bearing currents in variable speed drives

For more information on bearing currents, see “Technical guide No. 5, Bearing currents in modern AC drive systems”.

Common mode filters

Common mode filters reduce common mode currents and so decrease the risk of bearing currents. Common mode filters do not significantly affect the phase of main voltages on motor terminals. For more information, see ABB drives catalogs.

Insulated bearings

ABB uses bearings with insulated inner or outer races. Hybrid bearings, that is, bearings with non-conductive ceramic rolling elements, can also be used in special applications.

7. Cabling, grounding, and EMC

The use of a variable speed drive sets higher demands on the cabling and grounding of the drive system. The motor must be cabled using shielded symmetrical cables and cable glands providing 360° bonding (EMC glands, variant code 704). For motors up to 30 kW, asymmetrical cables can be used, but shielded cables are always recommended, especially if there are sensitive components in the driven application.

For motor sizes IEC 280 and above, additional potential equalization is needed between the motor frame and the machinery, unless the motor and the driven machine are installed on a common steel base. When a steel base is used for potential equalization, high frequency conductivity of the connection must be checked.

To meet EMC requirements, special EMC cables must be used in addition to appropriate cable gland mounting with special earthing pieces. Refer to ABB drives manuals for more information.

8. Motor loadability with frequency converter drives

The loadability curves shown in Figures 2 and 3 are generic and give indicative guide lines to make preliminary dimensioning of standard low voltage motors used with a frequency converter. It must be noted that the harmonic content and control algorithms vary between frequency converters, as well as the thermal margin and electrical properties of different motors. All this resulting in a slightly different loadability for each motor and converter combination.

The curves show the maximum continuous load torque as a function of frequency (speed), which results in the same temperature rise as operation with the rated sinusoidal supply at nominal frequency and full rated load.

Normally, Process performance motors operate according to class B temperature rise. For these motors, dimensioning should be done according to temperature rise B curve, or the motor can be slightly overloaded. In other words, it can be dimensioned according to temperature rise F curve.

However, if only class F temperature rise with a sinusoidal supply is indicated for the motor in the technical data section, dimensioning must be done according to the temperature rise curve B.

If the motor is loaded according the temperature rise F curve, it will be necessary to check the temperature rise in other parts of the motor and ensure that the lubrication intervals and grease type are still appropriate.

Temperature rise B

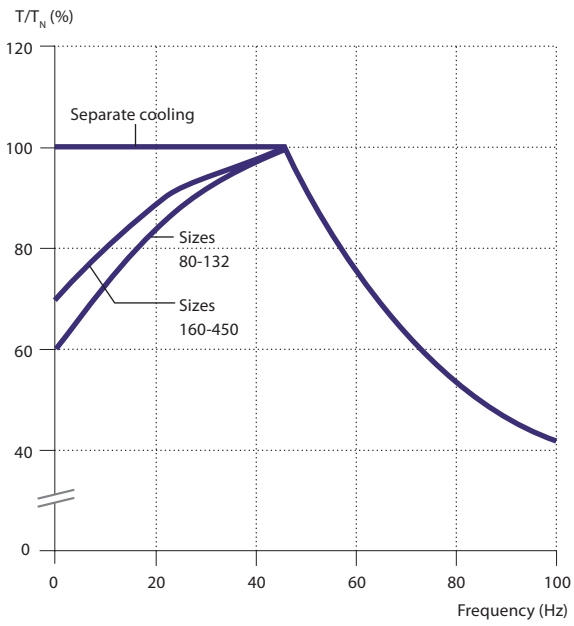

Figure 2a. Loadability curves for frequency converters with DTC control

Temperature rise F

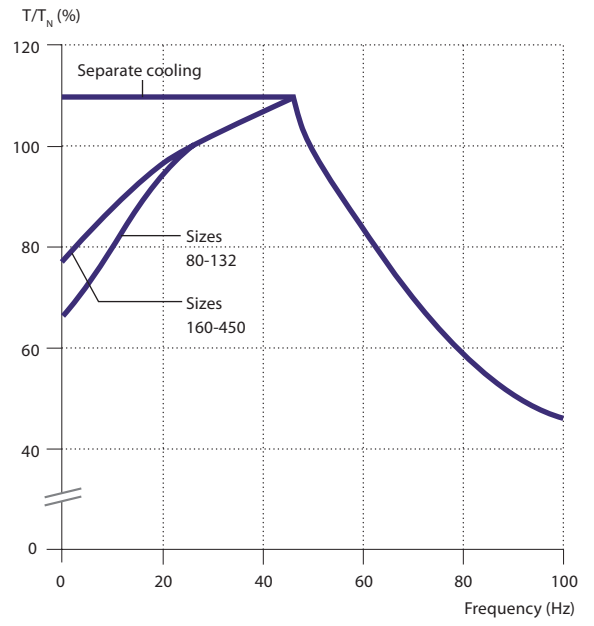

Figure 3a. Loadability curves for frequency converters with DTC control

Temperature rise B

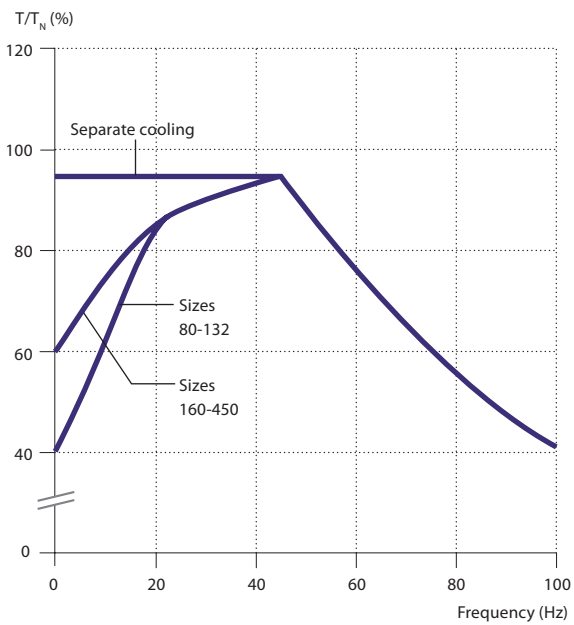

Figure 2b. Loadability curves for other frequency converters

Temperature rise F

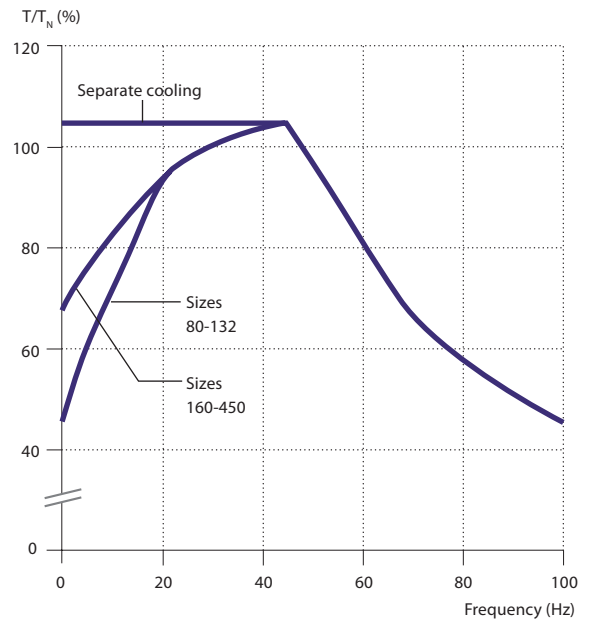

Figure 3b. Loadability curves for other frequency converters

Low voltage Process performance cast iron motors

Sizes 71 to 450, 0.09 to 1000 kW

| | |
|-----------------------------------------|-----------|
| Ordering information | 20 |
| Rating plates | 21 |
| Technical data IE2 | 22 |
| 3000 r/min motors | 22 |
| 1500 r/min motors | 24 |
| 1000 r/min motors | 26 |
| 750 r/min motors | 28 |
| 600 and 500 r/min motors | 30 |
| Technical data IE3 | 31 |
| 3000 r/min motors | 31 |
| 1500 r/min motors | 33 |
| 1000 r/min motors | 35 |
| Technical data IE4 | 37 |
| 3000, 1500, 1000 r/min motors | 37 |
| Variant codes | 38 |
| Mechanical design | 43 |
| Motor frame and drain holes | 43 |
| Bearings | 45 |
| Terminal box | 55 |
| Dimension drawings | 64 |
| Motor sizes 71 - 132 | 64 |
| Motor sizes 160 - 250 | 66 |
| Motor sizes 280 - 315 | 68 |
| Motor sizes 355 - 450 | 70 |
| Accessories | 72 |
| Built-in brake | 72 |
| Separate cooling | 74 |
| Silencer | 75 |
| Slide rails | 76 |
| Cast iron motors in brief | 78 |
| Motor sizes 71 - 132 | 78 |
| Motor sizes 160 - 250 | 79 |
| Motors sizes 280 - 450 | 80 |
| Motor construction | 81 |

Ordering information

Explanation of the product code

| Motor type | Motor size | Product code | Mounting arrangement code, Voltage and frequency code, Generation code | Variant codes |
|------------|------------|----------------------------------|------------------------------------------------------------------------------|---------------|
| M3BP | 160MLC | 3GBP 161 033 | - ADG | 003, etc. |
| | | 1 2 3 4 5 6 7 8 9 10 11 12 13 14 | | |

When placing an order, specify motor type, size and product code according to the following example.

| Example | |
|--------------------------------|-----------------|
| Motor type | M3BP 160 MLC |
| Pole number | 2 |
| Mounting arrangement (IM-code) | IM B3 (IM 1001) |
| Rated output | 18.5 kW |
| Product code | 3GBP161033-ADG |
| Variant codes if needed | |

Positions 1 to 4

3GBP: Totally enclosed fan cooled squirrel cage motor with cast iron frame

Positions 5 and 6

IEC size

| | |
|-----|-----|
| 07: | 71 |
| 08: | 80 |
| 09: | 90 |
| 10: | 100 |
| 12: | 112 |
| 13: | 132 |
| 16: | 160 |
| 18: | 180 |
| 20: | 200 |
| 22: | 225 |
| 25: | 250 |
| 28: | 280 |
| 31: | 315 |
| 35: | 355 |
| 40: | 400 |
| 45: | 450 |

Position 7

Speed (Pole pairs)

| | |
|----|-----------------------------------------------------------|
| 1: | 2 poles |
| 2: | 4 poles |
| 3: | 6 poles |
| 4: | 8 poles |
| 5: | 10 poles |
| 6: | 12 poles |
| 7: | > 12 poles |
| 8: | Two-speed motors for fan drive motors for constant torque |
| 9: | Multi-speed motors, two-speed |

Positions 8 to 10

Serial number

Position 11

-(dash)

Position 12 (marked with black dot in data tables)

Mounting arrangement

| | |
|----|------------------------------------------------------------|
| A: | Foot-mounted, top-mounted terminal box |
| R: | Foot-mounted, terminal box RHS seen from D-end |
| L: | Foot-mounted, terminal box LHS seen from D-end |
| B: | Flange-mounted, large flange |
| C: | Flange-mounted, small flange (sizes 71 to 112) |
| H: | Foot- and flange-mounted, terminal box top-mounted |
| J: | Foot- and flange-mounted, small flange with tapped holes |
| S: | Foot- and flange-mounted, terminal box RHS seen from D-end |
| T: | Foot- and flange-mounted, terminal box LHS seen from D-end |
| V: | Flange-mounted, special flange |
| F: | Foot- and flange-mounted. Special flange |

Position 13 (marked with black dot in data tables)

Voltage and frequency

Single-speed motors

| | |
|----|-------------------------------------------------------------|
| B: | 380 VΔ 50 Hz |
| D: | 400 VΔ, 415 VΔ, 690 VY 50 Hz |
| E: | 500 VΔ 50 Hz |
| F: | 500 VY 50 Hz |
| S: | 230 VΔ, 400 VY, 415 VY 50 Hz |
| T: | 660 VΔ 50 Hz |
| U: | 690 VΔ 50 Hz |
| X: | Other rated voltage, connection or frequency, 690 V maximum |

Two-speed motors

| | |
|----|-------------------------------------------------------------|
| A: | 220 V 50 Hz |
| B: | 380 V 50 Hz |
| D: | 400 V 50 Hz |
| E: | 500 V 50 Hz |
| S: | 230 V 50 Hz |
| X: | Other rated voltage, connection or frequency, 690 V maximum |

Remark: For voltage code X the variant code "209 Non-standard voltage or frequency (special winding)" must be ordered.

Position 14

Generation code

A, B, C...G...K: The product code must be, if needed, followed by variant codes.

Efficiency values are given according to IEC 60034-2-1; 2014

For detailed dimension drawings please see our web-pages 'www.abb.com/motors&generators' or contact ABB.

Rating plates

The motor's main rating plate shows the motor's performance values with various connections at nominal speed. The rating plate also shows the efficiency level (IE2, IE3, or IE4), year of manufacture, and the lowest nominal efficiency at 100, 75, and 50 % nominal load.

The plate samples shown on this page present typical data rows. The actual content of the plate may vary according to your order and according to the motor's IE class.

| | | | | | | | |
|-------------------------------------------------------------------|----|--------------------------|-------|------------|-------|------|------------------|
| ABB | | | | | | | |
| CE | | IE2 | | IEC60034-1 | | | |
| 3- Motor | | M3BP 100LC 4 IMB3/IM1001 | | | | 2015 | |
| 1044241-1 | | | | | | | |
| No. 3G1F1520266366 | | | | | | | |
| V | Hz | kW | r/min | A | cos φ | Duty | Ins. cl. F IP 55 |
| 690 | Y | 50 | 2.2 | 1450 | 2.75 | 0.78 | S1 |
| 400 | D | 50 | 2.2 | 1450 | 4.7 | 0.78 | S1 |
| 460 | D | 60 | 2.2 | 1755 | 4 | 0.77 | S1 |
| IE2-50Hz-85.9%(100%)-85.1%(75%)-83.4%(50%) / IE2-60Hz-87.6%(100%) | | | | | | | |
| Product code 3GBP102323-ADB | | | | | | | |
| 6206-2Z/C3 6205-2Z/C3 36 kg | | | | | | | |

Rating plate example, motor size 100, IE2

| | | | | | | | |
|-------------------------------------------------------------------|----|---------------------------|-------|------------|-------|------|------------------|
| ABB | | | | | | | |
| CE | | IE3 | | IEC60034-1 | | | |
| 3- Motor | | M3BP 160MLA 6 IMB3/IM1001 | | | | 2015 | |
| 1097747-1 | | | | | | | |
| No. 3G1F1538288845 | | | | | | | |
| V | Hz | kW | r/min | A | cos φ | Duty | Ins. cl. F IP 55 |
| 690 | Y | 50 | 7.5 | 980 | 8.81 | 0.78 | S1 |
| 400 | D | 50 | 7.5 | 980 | 15.2 | 0.78 | S1 |
| 660 | Y | 50 | 7.5 | 977 | 9.1 | 0.80 | S1 |
| 380 | D | 50 | 7.5 | 977 | 15.7 | 0.80 | S1 |
| 415 | D | 50 | 7.5 | 981 | 14.8 | 0.77 | S1 |
| 460 | D | 60 | 7.5 | 1182 | 13.5 | 0.76 | S1 |
| IE3-50Hz-90.4%(100%)-91.4%(75%)-91.2%(50%) / IE3-60Hz-91.4%(100%) | | | | | | | |
| Product code 3GBP163410-ADK | | | | | | | |
| 6309/C3 6209/C3 172 kg | | | | | | | |

Rating plate example, motor size 160, K generation, IE3

| | | | | | | | |
|-------------------------------------------------------------------|----|---------------------------|-------|------------|-------|------|------------------|
| ABB | | | | | | | |
| CE | | IE3 | | IEC60034-1 | | | |
| 3- Motor | | M3BP 315MLB 4 IMB3/IM1001 | | | | 2015 | |
| 1063997-1 | | | | | | | |
| No. 3G1F1528274631 | | | | | | | |
| V | Hz | kW | r/min | A | cos φ | Duty | Ins. cl. F IP 55 |
| 690 | Y | 50 | 200 | 1487 | 203 | 0.86 | S1 |
| 400 | D | 50 | 200 | 1487 | 351 | 0.86 | S1 |
| 415 | D | 50 | 200 | 1488 | 340 | 0.85 | S1 |
| 440 | D | 60 | 200 | 1788 | 314 | 0.87 | S1 |
| 460 | D | 60 | 200 | 1788 | 305 | 0.86 | S1 |
| IE3-50Hz-96.0%(100%)-96.4%(75%)-96.4%(50%) / IE3-60Hz-96.2%(100%) | | | | | | | |
| Product code 3GBP312420-ADL148473701704 | | | | | | | |
| Nmax 2300 r/min | | | | | | | |
| 6319/C3 6316/C3VL0241 1220 kg | | | | | | | |

Rating plate example, motor size 315, L generation, IE3

| | | | | | | | |
|---------------------------------------|----|---------------------------|-------|------------|-------|------|------------------|
| ABB | | | | | | | |
| CE | | IE4 | | IEC60034-1 | | | |
| 3- Motor | | M3BP 315MLB 4 IMB3/IM1001 | | | | 2015 | |
| 1042741-3 | | | | | | | |
| No. 3G1F1517265208 | | | | | | | |
| V | Hz | kW | r/min | A | cos φ | Duty | Ins. cl. F IP 55 |
| 690 | Y | 50 | 160 | 1489 | 161 | 0.86 | S1 |
| 400 | D | 50 | 160 | 1489 | 277 | 0.86 | S1 |
| 415 | D | 50 | 160 | 1490 | 270 | 0.85 | S1 |
| IE4-96.9%(100%)-97.0%(75%)-96.8%(50%) | | | | | | | |
| Product code 3GBP312420-ADM | | | | | | | |
| Nmax 2300 r/min | | | | | | | |
| 6319/C3 6316/C3 1220 kg | | | | | | | |

Rating plate example, motor size 315, IE4

Technical data

IE2 cast iron motors, 3000 r/min

IP 55 - IC 411 - Insulation class F, temperature rise class B
IE2 efficiency class according to IEC 60034-30-1; 2014

| Output kW | Motor type | Product code | Speed r/min | Efficiency IEC 60034-30-1; 2014 | | | Power factor Cosφ | Current Torque | | | | | Moment of inertia J = 1/4 GD ² kgm ² | Weight kg | Sound pressure Level L _{PA} dB |
|----------------------|------------------------------|----------------|-------------|---------------------------------|--------------|--------------|-------------------|------------------|--------------------------------|-------------------|--------------------------------|--------------------------------|------------------------------------------------------------|-----------|-----------------------------------------|
| | | | | Full load 100% | 3/4 load 75% | 1/2 load 50% | | I _N A | I _s /I _N | T _N Nm | T _i /T _N | T _b /T _N | | | |
| 3000 r/min = 2 poles | | | | 400 V 50 Hz | | | | CENELEC-design | | | | | | | |
| 0.37 | M3BP 71MA 2 | 3GBP071321-••B | 2768 | 74,8 | 75,4 | 72,4 | 0,78 | 0,9 | 4,5 | 1,3 | 2,2 | 2,3 | 0,000390 | 11 | 58 |
| 0.55 | M3BP 71MB 2 | 3GBP071322-••B | 2813 | 77,8 | 78,3 | 76,0 | 0,79 | 1,3 | 4,3 | 1,9 | 2,4 | 2,5 | 0,000510 | 11 | 56 |
| 0.75 | M3BP 80MB 2 | 3GBP081322-••B | 2895 | 80,6 | 79,6 | 75,6 | 0,74 | 1,8 | 7,7 | 2,4 | 4,2 | 4,2 | 0,00100 | 16 | 57 |
| 1.1 | M3BP 80MC 2 | 3GBP081323-••B | 2870 | 81,8 | 81,7 | 78,9 | 0,80 | 2,4 | 7,5 | 3,6 | 3,7 | 4,6 | 0,00120 | 18 | 60 |
| 1.5 | M3BP 90SLB 2 | 3GBP091322-••B | 2900 | 82,2 | 82,9 | 81,3 | 0,87 | 3,3 | 7,5 | 4,9 | 2,5 | 2,6 | 0,00254 | 24 | 69 |
| 2.2 | M3BP 90SLC 2 | 3GBP091323-••B | 2885 | 84,7 | 86,8 | 85,7 | 0,88 | 4,2 | 6,8 | 7,2 | 1,9 | 2,5 | 0,00280 | 25 | 64 |
| 3 | M3BP 100LB 2 | 3GBP101322-••B | 2925 | 85,2 | 84,9 | 82,7 | 0,87 | 5,8 | 9,1 | 9,7 | 3,1 | 3,5 | 0,00528 | 36 | 68 |
| 4 | M3BP 112MB 2 | 3GBP111322-••B | 2895 | 86,1 | 87,0 | 86,6 | 0,89 | 7,5 | 8,1 | 13,1 | 2,9 | 3,2 | 0,00575 | 37 | 70 |
| 5.5 | M3BP 132SMB 2 | 3GBP131322-••B | 2865 | 87,7 | 88,4 | 87,7 | 0,86 | 10,0 | 7,0 | 18,3 | 2,0 | 2,7 | 0,0128 | 68 | 70 |
| 7.5 | M3BP 132SMC 2 | 3GBP131324-••B | 2890 | 88,2 | 88,5 | 87,5 | 0,88 | 13,7 | 7,3 | 24,9 | 2,0 | 3,6 | 0,0136 | 70 | 70 |
| 11 | M3BP 160MLA 2 | 3GBP161410-••G | 2938 | 90,6 | 91,5 | 91,1 | 0,9 | 19,2 | 7,5 | 35,7 | 2,4 | 3,1 | 0,044 | 127 | 69 |
| 15 | M3BP 160MLB 2 | 3GBP161420-••G | 2934 | 91,5 | 92,4 | 92,2 | 0,90 | 26,0 | 7,5 | 48,8 | 2,5 | 3,3 | 0,053 | 141 | 69 |
| 22 | M3BP 180MLA 2 | 3GBP181410-••G | 2952 | 92,2 | 92,7 | 92,2 | 0,87 | 23,8 | 7,1 | 71,1 | 2,8 | 3,3 | 0,076 | 190 | 69 |
| 37 | M3BP 200MLB 2 | 3GBP201420-••G | 2959 | 93,4 | 93,7 | 92,9 | 0,90 | 63,5 | 8,2 | 119 | 3,0 | 3,3 | 0,20 | 298 | 72 |
| 45 | M3BP 225SMA2 | 3GBP221210-••G | 2961 | 93,6 | 93,9 | 93,1 | 0,88 | 78,8 | 6,7 | 145 | 2,5 | 2,5 | 0,24 | 347 | 74 |
| 55 | M3BP 250SMA 2 | 3GBP251210-••G | 2967 | 94,1 | 94,4 | 93,8 | 0,88 | 95,8 | 6,8 | 177 | 2,2 | 2,7 | 0,51 | 405 | 75 |
| 75 | M3BP 280SMA 2 | 3GBP281210-••G | 2978 | 94,3 | 94,1 | 92,8 | 0,88 | 130 | 7,6 | 240 | 2,1 | 3,0 | 0,80 | 625 | 77 |
| 90 | ³⁾ M3BP 280SMB 2 | 3GBP281220-••G | 2976 | 94,6 | 94,7 | 93,8 | 0,89 | 154 | 7,4 | 288 | 2,1 | 2,9 | 0,90 | 665 | 77 |
| 110 | ³⁾ M3BP 315SMA 2 | 3GBP311210-••G | 2982 | 94,9 | 94,4 | 92,9 | 0,86 | 197 | 7,4 | 352 | 2,2 | 3,2 | 1,20 | 940 | 78 |
| 132 | M3BP 315SMB 2 | 3GBP311220-••G | 2982 | 95,1 | 94,8 | 93,6 | 0,88 | 227 | 7,4 | 422 | 2,2 | 3,0 | 1,40 | 940 | 78 |
| 160 | ³⁾ M3BP 315SMC 2 | 3GBP311230-••G | 2981 | 95,4 | 95,2 | 94,2 | 0,89 | 271 | 7,5 | 512 | 2,3 | 3,0 | 1,70 | 1025 | 78 |
| 200 | ³⁾ M2BP 315MLA 2 | 3GBP311410-••G | 2980 | 95,7 | 95,7 | 94,9 | 0,90 | 335 | 7,7 | 640 | 2,6 | 3,0 | 2,10 | 1190 | 78 |
| 250 | ³⁾ M3BP 355SMA 2 | 3GBP351210-••G | 2984 | 95,7 | 95,5 | 94,5 | 0,89 | 423 | 7,7 | 800 | 2,1 | 3,3 | 3,00 | 1600 | 83 |
| 315 | ³⁾ M3BP 355SMB 2 | 3GBP351220-••G | 2980 | 95,7 | 95,6 | 95,0 | 0,89 | 531 | 7,0 | 1009 | 2,1 | 3,0 | 3,40 | 1680 | 83 |
| 355 | ³⁾ M3BP 355SMC 2 | 3GBP351230-••G | 2984 | 95,7 | 95,7 | 94,9 | 0,88 | 603 | 7,2 | 1136 | 2,2 | 3,0 | 3,60 | 1750 | 83 |
| 400 | ³⁾ M3BP 355MLA 2 | 3GBP351410-••G | 2982 | 96,9 | 96,6 | 95,9 | 0,88 | 677 | 7,1 | 1280 | 2,3 | 2,9 | 4,10 | 2000 | 83 |
| 450 | ³⁾ M3BP 355MLB 2 | 3GBP351420-••G | 2983 | 97,1 | 97,0 | 96,4 | 0,90 | 743 | 7,9 | 1440 | 2,2 | 2,9 | 4,30 | 2080 | 83 |
| 500 | ³⁾ M3BP 355LKA 2 | 3GBP351810-••G | 2982 | 96,9 | 96,9 | 96,5 | 0,90 | 827 | 7,5 | 1601 | 2,0 | 3,9 | 4,80 | 2320 | 83 |
| 560 | ³⁾ M3BP 400LA 2 | 3GBP401510-••G | 2988 | 97,2 | 97,2 | 96,6 | 0,89 | 934 | 7,8 | 1789 | 2,5 | 3,7 | 7,90 | 2950 | 82 |
| 560 | ³⁾ M3BP 355LKB 2 | 3GBP351820-••G | 2983 | 97,0 | 97,0 | 96,5 | 0,90 | 925 | 8,0 | 1792 | 2,2 | 4,1 | 5,20 | 2460 | 83 |
| 630 | ²⁾ M3BP 400LB 2 | 3GBP401520-••G | 2987 | 97,4 | 97,2 | 96,7 | 0,89 | 1049 | 7,6 | 2014 | 2,6 | 3,7 | 8,20 | 3050 | 82 |
| 710 | ²⁾ M3BP 400LC 2 | 3GBP401530-••G | 2987 | 97,5 | 97,4 | 96,9 | 0,89 | 1178 | 7,2 | 2270 | 2,6 | 3,4 | 9,30 | 3300 | 82 |
| 800 | ¹⁾²⁾ M3BP 450LA 2 | 3GBP451510-••G | 2990 | 97,4 | 97,2 | 96,6 | 0,87 | 1362 | 7,8 | 2555 | 1,3 | 3,4 | 12,20 | 4000 | 85 |
| 900 | ¹⁾²⁾ M3BP 450LB 2 | 3GBP451520-••G | 2990 | 97,0 | 96,8 | 96,2 | 0,87 | 1534 | 7,6 | 2874 | 1,5 | 3,1 | 13,50 | 4200 | 85 |

¹⁾ Temperature rise class F

²⁾ Unidirectional fan, variant code 044 or 045 is mandatory

³⁾ 3dB(A) sound pressure level reduction with unidirectional fan construction. Direction of rotation must be stated when ordering, see variant codes 044 and 045

Technical data

IE2 cast iron motors, 3000 r/min

IP 55 - IC 411 - Insulation class F, temperature rise class B
IE2 efficiency class according to IEC 60034-30-1; 2014

| Output kW | Motor type | Product code | Speed r/min | Efficiency IEC 60034-30-1; 2014 | | | Power factor Cos ϕ | Current Torque | | | | | Moment of inertia J = 1/4 GD ² kgm ² | Weight kg | Sound pressure Level L _{PA} dB |
|-----------------------------|-----------------------------|----------------|----------------|------------------------------------|--------------------|--------------------|-------------------------------|---------------------------|--------------------------------|----------------------|--------------------------------|--------------------------------|---------------------------------------------------------------------|--------------|--------------------------------------------------|
| | | | | Full load 100% | 3/4 load 75% | 1/2 load 50% | | I _N A | I _s /I _N | T _N Nm | T _f /T _N | T _b /T _N | | | |
| 3000 r/min = 2 poles | | | | 400 V 50 Hz | | | | High-output design | | | | | | | |
| 22 | M3BP 160MLD 2 | 3GBP161440-••G | 2933 | 91,7 | 92,8 | 92,8 | 0,90 | 38,0 | 8,1 | 71,6 | 3,2 | 3,6 | 0,0630 | 170 | 69 |
| 27 | M3BP 160MLE 2 | 3GBP161450-••G | 2939 | 92,2 | 93,1 | 93,0 | 0,90 | 46,4 | 8,8 | 87,7 | 3,4 | 3,8 | 0,0720 | 184 | 69 |
| 30 | M3BP 180MLB 2 | 3GBP181420-••G | 2950 | 92,7 | 93,5 | 93,3 | 0,88 | 53,0 | 7,9 | 97,1 | 2,8 | 3,3 | 0,0920 | 208 | 69 |
| 45 | ¹⁾ M3BP 200MLC 2 | 3GBP201430-••G | 2957 | 93,3 | 93,8 | 93,2 | 0,88 | 79,1 | 8,1 | 145 | 3,1 | 3,3 | 0,196 | 298 | 72 |
| 55 | ¹⁾ M3BP 200MLD 2 | 3GBP201440-••G | 2953 | 93,8 | 94,4 | 94,3 | 0,89 | 95,0 | 7,8 | 177 | 2,9 | 3,3 | 0,217 | 314 | 72 |
| 55 | M3BP 225SMB 2 | 3GBP221220-••G | 2961 | 93,9 | 94,3 | 93,6 | 0,88 | 96,0 | 6,5 | 177 | 2,4 | 2,5 | 0,274 | 369 | 74 |
| 75 | ¹⁾ M3BP 225SMC 2 | 3GBP221230-••G | 2969 | 94,4 | 94,6 | 94,0 | 0,84 | 136 | 7,4 | 241 | 3,2 | 3,1 | 0,309 | 396 | 74 |
| 75 | M3BP 250SMB 2 | 3GBP251220-••G | 2970 | 94,5 | 94,8 | 94,4 | 0,89 | 128 | 7,6 | 241 | 2,8 | 3,1 | 0,583 | 451 | 75 |
| 80 | ¹⁾ M3BP 225SMD 2 | 3GBP221240-••G | 2964 | 94,4 | 94,8 | 94,3 | 0,87 | 140 | 7,3 | 257 | 3,0 | 2,8 | 0,329 | 410 | 74 |
| 90 | ¹⁾ M3BP 250SMC 2 | 3GBP251230-••G | 2971 | 94,9 | 95,2 | 94,8 | 0,89 | 153 | 7,6 | 289 | 2,5 | 3,1 | 0,644 | 487 | 75 |
| 110 | ³⁾ M3BP 280SMC 2 | 3GBP281230-••G | 2978 | 95,1 | 95,1 | 94,5 | 0,90 | 186 | 7,9 | 352 | 2,4 | 3,0 | 1,15 | 725 | 77 |
| 132 | ³⁾ M3BP 280MLA 2 | 3GBP281410-••G | 2977 | 95,3 | 95,3 | 94,8 | 0,90 | 221 | 7,5 | 423 | 2,5 | 3,0 | 1,40 | 840 | 81 |
| 160 | ³⁾ M3BP 280MLB 2 | 3GBP281420-••G | 2976 | 95,5 | 95,7 | 95,3 | 0,91 | 265 | 7,6 | 513 | 2,8 | 3,0 | 1,55 | 890 | 81 |
| 250 | ³⁾ M3BP 315LKA 2 | 3GBP311810-••G | 2980 | 95,7 | 95,7 | 95,2 | 0,89 | 423 | 8,1 | 801 | 2,8 | 2,9 | 2,65 | 1440 | 78 |
| 315 | ³⁾ M3BP 315LKC 2 | 3GBP311830-••G | 2981 | 95,7 | 95,7 | 95,4 | 0,89 | 533 | 8,8 | 1009 | 3,2 | 3,2 | 3,30 | 1630 | 78 |

¹⁾ Temperature rise class F

²⁾ -3 dB(A) sound pressure level reduction with unidirectional fan construction. The direction of rotation of the fan must be stated when ordering, see variant codes 045 and 045.

Technical data

IE2 cast iron motors, 1500 r/min

IP 55 - IC 411 - Insulation class F, temperature rise class B
IE2 efficiency class according to IEC 60034-30-1; 2014

| Output kW | Motor type | Product code | Speed r/min | Efficiency IEC 60034-30-1; 2014 | | | Power factor Cosφ | Current Torque | | | | | Moment of inertia J = 1/4 GD ² kgm ² | Weight kg | Sound pressure Level L _{PA} dB |
|----------------------|-----------------------------|----------------|-------------|---------------------------------|--------------|--------------|-------------------|------------------|--------------------------------|-------------------|--------------------------------|--------------------------------|------------------------------------------------------------|-----------|-----------------------------------------|
| | | | | Full load 100% | 3/4 load 75% | 1/2 load 50% | | I _N A | I _s /I _N | T _N Nm | T _i /T _N | T _b /T _N | | | |
| 1500 r/min = 4 poles | | | | 400 V 50 Hz | | | CENELEC-design | | | | | | | | |
| 0.25 | M3BP 71MA 4 | 3GBP072321-••B | 1365 | 68,3 | 70,7 | 69,6 | 0,81 | 0,6 | 3,5 | 1,7 | 1,9 | 2,0 | 0,000740 | 10 | 45 |
| 0.37 | M3BP 71MB 4 | 3GBP072322-••B | 1380 | 72,4 | 74,5 | 74,7 | 0,83 | 0,9 | 4,6 | 2,5 | 1,6 | 2,1 | 0,000880 | 11 | 45 |
| 0.55 | M3BP 80MA 4 | 3GBP082321-••B | 1415 | 74,5 | 73,8 | 70,0 | 0,73 | 1,4 | 5,0 | 3,7 | 2,0 | 2,8 | 0,00144 | 15 | 45 |
| 0.75 | M3BP 80MD 4 | 3GBP082324-••B | 1430 | 81,0 | 81,0 | 78,2 | 0,73 | 1,8 | 5,3 | 5,0 | 2,7 | 3,2 | 0,00205 | 17 | 50 |
| 1.1 | M3BP 90SLB 4 | 3GBP092322-••B | 1435 | 83,6 | 84,1 | 82,4 | 0,80 | 2,4 | 6,5 | 7,3 | 2,4 | 3,4 | 0,00440 | 25 | 50 |
| 1.5 | M3BP 90SLD 4 | 3GBP092325-••B | 1430 | 84,3 | 85,1 | 83,9 | 0,83 | 3,0 | 6,3 | 10,0 | 2,7 | 3,4 | 0,00530 | 27 | 56 |
| 2.2 | M3BP 100LC 4 | 3GBP102323-••B | 1450 | 85,9 | 85,1 | 83,4 | 0,78 | 4,6 | 7,7 | 14,5 | 2,7 | 4,1 | 0,00948 | 36 | 56 |
| 3 | M3BP 100LD 4 | 3GBP102324-••B | 1450 | 86,8 | 86,9 | 85,3 | 0,79 | 6,1 | 7,7 | 19,8 | 2,9 | 3,4 | 0,0110 | 38 | 58 |
| 4 | M3BP 112MB 4 | 3GBP112322-••B | 1440 | 86,8 | 87,7 | 87,3 | 0,82 | 7,9 | 7,0 | 26,5 | 2,5 | 2,9 | 0,0125 | 44 | 59 |
| 5.5 | M3BP 132SMB 4 | 3GBP132322-••B | 1460 | 89,0 | 89,8 | 88,9 | 0,80 | 10,8 | 6,7 | 36,0 | 2,2 | 3,2 | 0,0328 | 70 | 67 |
| 7.5 | M3BP 132SMC 4 | 3GBP132323-••B | 1450 | 89,3 | 90,1 | 90,0 | 0,81 | 14,5 | 7,2 | 49,4 | 2,5 | 3,5 | 0,0366 | 73 | 64 |
| 11 | M3BP 160MLA 4 | 3GBP162410-••G | 1466 | 90,4 | 91,6 | 91,3 | 0,84 | 20,9 | 6,8 | 71,6 | 2,2 | 2,8 | 0,0810 | 135 | 62 |
| 15 | M3BP 160MLB 4 | 3GBP162420-••G | 1470 | 91,4 | 92,3 | 92,2 | 0,83 | 28,5 | 7,1 | 97,4 | 2,6 | 3,0 | 0,0990 | 165 | 62 |
| 18.5 | M3BP 180MLA 4 | 3GBP182410-••G | 1477 | 91,9 | 92,8 | 92,6 | 0,84 | 34,5 | 7,2 | 119 | 2,6 | 2,9 | 0,166 | 205 | 62 |
| 22 | M3BP 180MLB 4 | 3GBP182420-••G | 1475 | 92,3 | 93,3 | 93,2 | 0,84 | 40,9 | 7,3 | 142 | 2,6 | 3,0 | 0,195 | 222 | 62 |
| 30 | M3BP 200MLA 4 | 3GBP202410-••G | 1480 | 93,2 | 94,0 | 93,7 | 0,84 | 55,3 | 7,4 | 193 | 2,8 | 3,0 | 0,309 | 291 | 63 |
| 37 | M3BP 225SMA 4 | 3GBP222210-••G | 1479 | 93,4 | 93,9 | 93,4 | 0,84 | 68,0 | 7,1 | 238 | 2,6 | 2,9 | 0,356 | 324 | 66 |
| 45 | M3BP 225SMB 4 | 3GBP222220-••G | 1480 | 93,9 | 94,3 | 93,9 | 0,85 | 81,3 | 7,5 | 290 | 2,8 | 3,2 | 0,440 | 356 | 66 |
| 55 | M3BP 250SMA 4 | 3GBP252210-••G | 1480 | 94,4 | 94,9 | 94,6 | 0,85 | 98,9 | 7,0 | 354 | 2,6 | 2,9 | 0,765 | 414 | 67 |
| 75 | M3BP 280SMA 4 | 3GBP282210-••G | 1484 | 94,5 | 94,7 | 94,4 | 0,85 | 134 | 6,9 | 482 | 2,5 | 2,8 | 1,25 | 625 | 68 |
| 90 | M3BP 280SMB 4 | 3GBP282220-••G | 1483 | 94,7 | 95,0 | 94,5 | 0,85 | 160 | 7,2 | 579 | 2,5 | 2,7 | 1,50 | 665 | 68 |
| 110 | M3BP 315SMA 4 | 3GBP312210-••G | 1487 | 95,1 | 95,1 | 94,3 | 0,86 | 194 | 7,2 | 706 | 2,3 | 2,8 | 2,30 | 900 | 70 |
| 132 | M3BP 315SMB 4 | 3GBP312220-••G | 1487 | 95,4 | 95,4 | 94,7 | 0,86 | 232 | 7,1 | 847 | 2,3 | 2,7 | 2,60 | 960 | 70 |
| 160 | M3BP 315SMC 4 | 3GBP312230-••G | 1487 | 95,3 | 95,3 | 94,8 | 0,85 | 284 | 7,2 | 1027 | 2,4 | 2,9 | 2,90 | 1000 | 70 |
| 200 | M3BP 315MLA 4 | 3GBP312410-••G | 1486 | 95,6 | 95,6 | 95,3 | 0,86 | 351 | 7,2 | 1285 | 2,5 | 2,9 | 3,50 | 1160 | 70 |
| 250 | M3BP 355SMA 4 | 3GBP352210-••G | 1488 | 95,9 | 96,0 | 95,5 | 0,85 | 442 | 7,1 | 1604 | 2,3 | 2,7 | 5,90 | 1610 | 74 |
| 315 | M3BP 355SMB 4 | 3GBP352220-••G | 1488 | 95,9 | 96,2 | 95,8 | 0,86 | 550 | 7,3 | 2021 | 2,3 | 2,8 | 6,90 | 1780 | 74 |
| 355 | M3BP 355SMC 4 | 3GBP352230-••G | 1487 | 95,9 | 96,2 | 95,9 | 0,87 | 614 | 6,8 | 2279 | 2,4 | 2,7 | 7,20 | 1820 | 78 |
| 400 | M3BP 355MLA 4 | 3GBP352410-••G | 1489 | 96,3 | 96,3 | 95,9 | 0,85 | 705 | 6,8 | 2565 | 2,3 | 2,6 | 8,40 | 2140 | 78 |
| 450 | M3BP 355MLB 4 | 3GBP352420-••G | 1490 | 96,7 | 96,7 | 96,1 | 0,86 | 780 | 6,9 | 2884 | 2,3 | 2,9 | 8,40 | 2140 | 78 |
| 500 | M3BP 355LKA 4 | 3GBP352810-••G | 1490 | 97,0 | 97,0 | 96,5 | 0,86 | 865 | 6,8 | 3204 | 2,0 | 3,0 | 10,0 | 2500 | 78 |
| 560 | ¹⁾ M3BP 355LKB 4 | 3GBP352820-••G | 1490 | 96,9 | 96,9 | 96,5 | 0,85 | 981 | 7,2 | 3588 | 2,6 | 2,7 | 10,6 | 2600 | 78 |
| 560 | ¹⁾ M3BP 400LA 4 | 3GBP402510-••G | 1491 | 96,8 | 96,8 | 96,3 | 0,85 | 982 | 7,4 | 3586 | 2,4 | 2,8 | 15,0 | 3200 | 78 |
| 630 | M3BP 400LB 4 | 3GBP402520-••G | 1491 | 97,0 | 97,0 | 96,5 | 0,87 | 1077 | 7,6 | 4034 | 2,2 | 2,9 | 16,0 | 3300 | 78 |
| 710 | ¹⁾ M3BP 400LC 4 | 3GBP402530-••G | 1491 | 97,1 | 97,1 | 96,7 | 0,86 | 1227 | 7,6 | 4547 | 2,4 | 3,0 | 17,0 | 3400 | 78 |
| 800 | M3BP 450LA 4 | 3GBP452510-••G | 1491 | 96,9 | 96,9 | 96,4 | 0,86 | 1396 | 7,0 | 5121 | 1,3 | 2,8 | 23,0 | 4050 | 85 |
| 900 | M3BP 450LB 4 | 3GBP452520-••G | 1492 | 97,1 | 97,0 | 96,5 | 0,86 | 1573 | 7,0 | 5761 | 1,3 | 2,8 | 25,0 | 4350 | 85 |
| 1000 | ¹⁾ M3BP 450LC 4 | 3GBP452530-••G | 1491 | 97,2 | 97,2 | 96,7 | 0,86 | 1724 | 6,8 | 6404 | 1,3 | 2,7 | 30,0 | 4700 | 85 |

¹⁾ Temperature rise class F

Technical data

IE2 cast iron motors, 1500 r/min

IP 55 - IC 411 - Insulation class F, temperature rise class B
IE2 efficiency class according to IEC 60034-30-1; 2014

| Output kW | Motor type | Product code | Speed r/min | Efficiency IEC 60034-30-1; 2014 | | | Power factor $\cos\phi$ | Current Torque | | | | | Moment of inertia $J = 1/4$ GD^2kgm^2 | Weight kg | Sound pressure Level L_{PA} dB |
|-----------------------------|-----------------------------|----------------|-------------|---------------------------------|--------------|--------------|-------------------------|---------------------------|-----------|----------|-----------|-----------|-------------------------------------------------------|-----------|----------------------------------|
| | | | | Full load 100% | 3/4 load 75% | 1/2 load 50% | | I_N A | I_s/I_N | T_N Nm | T_f/T_N | T_b/T_N | | | |
| 1500 r/min = 4 poles | | | | 400 V 50 Hz | | | | High-output design | | | | | | | |
| 18.5 | M3BP 160MLC 4 | 3GBP162430-••G | 1469 | 91,4 | 92,4 | 92,2 | 0,84 | 34,7 | 7,6 | 120 | 3,0 | 3,2 | 0,110 | 173 | 62 |
| 22 | ¹⁾ M3BP 160MLD 4 | 3GBP162440-••G | 1463 | 91,6 | 93,0 | 93,2 | 0,85 | 40,7 | 6,9 | 143 | 2,5 | 2,9 | 0,125 | 187 | 62 |
| 30 | ¹⁾ M3BP 180MLC 4 | 3GBP182430-••G | 1474 | 92,3 | 93,5 | 93,5 | 0,83 | 56,5 | 7,3 | 194 | 2,7 | 2,9 | 0,217 | 235 | 62 |
| 37 | M3BP 200MLB 4 | 3GBP202420-••G | 1479 | 93,4 | 94,4 | 94,4 | 0,85 | 67,2 | 7,1 | 238 | 2,6 | 2,9 | 0,343 | 307 | 63 |
| 45 | ¹⁾ M3BP 200MLC 4 | 3GBP202430-••G | 1479 | 93,6 | 94,4 | 94,2 | 0,83 | 83,6 | 7,5 | 290 | 2,9 | 3,2 | 0,366 | 319 | 63 |
| 55 | M3BP 225SMC 4 | 3GBP222230-••G | 1478 | 94,0 | 94,6 | 94,4 | 0,85 | 99,3 | 7,4 | 355 | 2,9 | 3,1 | 0,474 | 370 | 66 |
| 64 | M3BP 225SMD 4 | 3GBP222240-••G | 1480 | 94,2 | 94,6 | 94,1 | 0,85 | 115 | 8,2 | 412 | 3,3 | 3,3 | 0,542 | 399 | 66 |
| 75 | ¹⁾ M3BP 250SMB 4 | 3GBP252220-••G | 1478 | 94,4 | 95,1 | 94,8 | 0,85 | 134 | 7,3 | 484 | 2,8 | 3,1 | 0,866 | 450 | 67 |
| 90 | ¹⁾ M3BP 250SMC 4 | 3GBP252230-••G | 1478 | 94,6 | 95,3 | 95,0 | 0,84 | 163 | 7,4 | 581 | 3,1 | 3,3 | 0,941 | 478 | 67 |
| 110 | M3BP 280SMC 4 | 3GBP282230-••G | 1485 | 95,1 | 95,4 | 95,1 | 0,86 | 193 | 7,6 | 707 | 3,0 | 3,0 | 1,85 | 725 | 68 |
| 132 | M3BP 280MLA 4 | 3GBP282410-••G | 1483 | 95,3 | 95,5 | 95,1 | 0,86 | 232 | 7,0 | 849 | 2,7 | 2,8 | 2,30 | 840 | 75 |
| 160 | M3BP 280MLB 4 | 3GBP282420-••G | 1484 | 95,6 | 95,9 | 95,7 | 0,85 | 284 | 7,4 | 1029 | 2,9 | 2,9 | 2,50 | 890 | 75 |
| 250 | M3BP 315LKA 4 | 3GBP312810-••G | 1487 | 95,7 | 95,8 | 95,2 | 0,85 | 443 | 7,4 | 1605 | 2,5 | 2,9 | 4,40 | 1410 | 78 |
| 280 | M3BP 315LKB 4 | 3GBP312820-••G | 1487 | 95,8 | 95,9 | 95,4 | 0,87 | 491 | 7,6 | 1798 | 2,6 | 3,0 | 5,00 | 1520 | 78 |
| 315 | M3BP 315LKC 4 | 3GBP312830-••G | 1488 | 95,8 | 95,9 | 95,3 | 0,86 | 559 | 7,8 | 2021 | 2,6 | 3,2 | 5,50 | 1600 | 78 |

¹⁾ Temperature rise class F

Technical data

IE2 cast iron motors, 1000 r/min

IP 55 - IC 411 - Insulation class F, temperature rise class B
IE2 efficiency class according to IEC 60034-30-1; 2014

| Output kW | Motor type | Product code | Speed r/min | Efficiency IEC 60034-30-1; 2014 | | | Power factor Cosφ | Current Torque | | | | | Moment of inertia J = 1/4 GD ² kgm ² | Weight kg | Sound pressure Level L _{PA} dB |
|----------------------|----------------------------|----------------|-------------|---------------------------------|--------------|--------------|-------------------|------------------|--------------------------------|-------------------|--------------------------------|--------------------------------|------------------------------------------------------------|-----------|-----------------------------------------|
| | | | | Full load 100% | 3/4 load 75% | 1/2 load 50% | | I _N A | I _s /I _N | T _N Nm | T _i /T _N | T _b /T _N | | | |
| 1000 r/min = 6 poles | | | | 400 V 50 Hz | | | | CENELEC-design | | | | | | | |
| 0.18 | M3BP 71MA 6 | 3GBP073321-••B | 900 | 63,7 | 63,8 | 59,0 | 0,71 | 0,6 | 3,1 | 1,9 | 2,0 | 2,1 | 0,000890 | 10 | 42 |
| 0.25 | M3BP 71MB 6 | 3GBP073322-••B | 915 | 67,2 | 65,5 | 59,5 | 0,69 | 0,8 | 3,7 | 2,6 | 2,6 | 2,7 | 0,00110 | 12 | 42 |
| 0.37 | M3BP 80MA 6 | 3GBP083321-••B | 925 | 71,0 | 70,0 | 65,0 | 0,69 | 1,1 | 4,1 | 3,8 | 2,4 | 2,5 | 0,00187 | 15 | 47 |
| 0.55 | M3BP 80MB 6 | 3GBP083322-••B | 920 | 73,9 | 75,0 | 72,8 | 0,71 | 1,5 | 3,8 | 5,7 | 1,8 | 2,2 | 0,00239 | 17 | 47 |
| 0.75 | M3BP 90SLC 6 | 3GBP093323-••B | 960 | 78,7 | 77,2 | 72,5 | 0,58 | 2,3 | 4,5 | 7,4 | 2,4 | 3,1 | 0,00491 | 25 | 44 |
| 1.1 | M3BP 90SLE 6 | 3GBP093324-••B | 930 | 78,2 | 78,7 | 76,5 | 0,66 | 3,0 | 4,0 | 11,2 | 1,9 | 2,3 | 0,00540 | 28 | 44 |
| 1.5 | M3BP 100L 6 | 3GBP103322-••B | 950 | 82,2 | 83,0 | 81,6 | 0,69 | 3,7 | 4,3 | 15,0 | 1,5 | 2,7 | 0,00873 | 37 | 49 |
| 2.2 | M3BP 112MB 6 | 3GBP113322-••B | 950 | 82,5 | 83,7 | 81,6 | 0,69 | 5,5 | 4,4 | 22,1 | 1,7 | 2,3 | 0,0125 | 44 | 66 |
| 3 | M3BP 132SMB 6 | 3GBP133321-••B | 975 | 85,3 | 84,2 | 81,2 | 0,63 | 8,0 | 5,5 | 29,4 | 1,8 | 2,9 | 0,0334 | 69 | 57 |
| 4 | M3BP 132SMC 6 | 3GBP133322-••B | 960 | 84,9 | 85,3 | 83,9 | 0,68 | 10,0 | 4,6 | 39,7 | 1,5 | 2,2 | 0,0334 | 69 | 57 |
| 5.5 | M3BP 132SMF 6 | 3GBP133324-••B | 965 | 86,1 | 86,5 | 85,4 | 0,71 | 12,9 | 5,1 | 54,4 | 2,0 | 2,3 | 0,0487 | 86 | 57 |
| 7.5 | M3BP 160MLA 6 | 3GBP163410-••G | 975 | 88,5 | 89,9 | 89,7 | 0,79 | 15,4 | 7,4 | 73,4 | 1,7 | 3,2 | 0,087 | 134 | 59 |
| 11 | M3BP 160MLB 6 | 3GBP163420-••G | 972 | 89,3 | 90,6 | 90,5 | 0,79 | 22,5 | 7,5 | 108 | 1,9 | 2,9 | 0,114 | 172 | 59 |
| 15 | M3BP 180MLA 6 | 3GBP183410-••G | 977 | 90,2 | 91,2 | 90,7 | 0,76 | 31,5 | 5,8 | 146 | 1,8 | 2,7 | 0,168 | 207 | 59 |
| 18.5 | M3BP 200MLA 6 | 3GBP203410-••G | 988 | 91,6 | 92,2 | 91,7 | 0,80 | 36,4 | 6,7 | 178 | 2,3 | 2,9 | 0,382 | 269 | 63 |
| 22 | M3BP 200MLB 6 | 3GBP203420-••G | 987 | 92,0 | 92,9 | 92,7 | 0,82 | 42,0 | 6,6 | 212 | 2,2 | 2,8 | 0,448 | 291 | 63 |
| 30 | M3BP 225SMA 6 | 3GBP223210-••G | 986 | 92,6 | 93,3 | 92,8 | 0,83 | 56,2 | 7,0 | 290 | 2,6 | 2,9 | 0,663 | 349 | 63 |
| 37 | M3BP 250SMA 6 | 3GBP253210-••G | 989 | 93,1 | 93,8 | 93,4 | 0,82 | 69,9 | 6,8 | 357 | 2,4 | 2,7 | 1,13 | 395 | 63 |
| 45 | M3BP 280SMA 6 | 3GBP283210-••G | 990 | 93,4 | 93,8 | 93,5 | 0,83 | 83,8 | 7,0 | 434 | 2,5 | 2,5 | 1,85 | 605 | 66 |
| 55 | M3BP 280SMB 6 | 3GBP283220-••G | 990 | 93,8 | 94,2 | 93,9 | 0,84 | 100 | 7,0 | 530 | 2,7 | 2,6 | 2,20 | 645 | 66 |
| 75 | M3BP 315SMA 6 | 3GBP313210-••G | 992 | 94,4 | 94,4 | 93,5 | 0,82 | 139 | 7,4 | 721 | 2,4 | 2,8 | 3,20 | 830 | 70 |
| 90 | M3BP 315SMB 6 | 3GBP313220-••G | 992 | 94,8 | 94,7 | 94,1 | 0,84 | 166 | 7,5 | 866 | 2,4 | 2,8 | 4,10 | 930 | 70 |
| 110 | M3BP 315SMC 6 | 3GBP313230-••G | 991 | 95,0 | 95,0 | 94,6 | 0,83 | 201 | 7,4 | 1059 | 2,5 | 2,9 | 4,90 | 1000 | 70 |
| 132 | M3BP 315MLA 6 | 3GBP313410-••G | 991 | 95,3 | 95,4 | 94,9 | 0,83 | 240 | 7,5 | 1271 | 2,7 | 3,0 | 5,80 | 1150 | 68 |
| 160 | M3BP 355SMA 6 | 3GBP353810-••G | 992 | 94,9 | 95,2 | 95,0 | 0,83 | 293 | 6,3 | 1540 | 2,3 | 2,2 | 7,90 | 1520 | 75 |
| 200 | M3BP 355SMB 6 | 3GBP353220-••G | 993 | 95,7 | 95,9 | 95,7 | 0,83 | 364 | 7,2 | 1923 | 2,2 | 2,7 | 9,70 | 1680 | 75 |
| 250 | M3BP 355SMC 6 | 3GBP353230-••G | 993 | 95,7 | 95,8 | 95,4 | 0,82 | 460 | 7,4 | 2404 | 2,6 | 2,9 | 11,3 | 1820 | 75 |
| 315 | M3BP 355MLB 6 | 3GBP353420-••G | 992 | 95,7 | 96,0 | 95,5 | 0,83 | 570 | 7,0 | 3032 | 2,5 | 2,7 | 13,5 | 2180 | 75 |
| 355 | M3BP 355LKA 6 | 3GBP353810-••G | 992 | 95,7 | 95,9 | 95,4 | 0,81 | 658 | 7,6 | 3417 | 2,7 | 2,9 | 15,5 | 2500 | 75 |
| 400 | M3BP 355LKB 6 | 3GBP353820-••G | 992 | 96,0 | 96,0 | 95,5 | 0,83 | 724 | 7,2 | 3850 | 2,6 | 2,6 | 16,5 | 2600 | 75 |
| 400 | M3BP 400LA 6 | 3GBP403510-••G | 993 | 96,2 | 96,2 | 95,6 | 0,82 | 731 | 7,1 | 3846 | 2,3 | 2,7 | 17,0 | 2900 | 76 |
| 450 | M3BP 400LB 6 | 3GBP403520-••G | 994 | 96,6 | 96,6 | 96,1 | 0,82 | 819 | 7,4 | 4323 | 2,4 | 2,8 | 20,5 | 3150 | 76 |
| 500 | M3BP 400LC 6 | 3GBP403530-••G | 993 | 96,6 | 96,5 | 96,1 | 0,83 | 891 | 7,2 | 4809 | 2,5 | 2,7 | 22,0 | 3300 | 76 |
| 560 | M3BP 400LD 6 | 3GBP403540-••G | 993 | 96,9 | 96,9 | 96,4 | 0,85 | 984 | 7,4 | 5386 | 2,4 | 2,8 | 24,0 | 3400 | 77 |
| 630 | M3BP 450LA 6 | 3GBP453510-••G | 994 | 96,7 | 96,7 | 96,3 | 0,84 | 1127 | 6,5 | 6053 | 1,1 | 2,5 | 31,0 | 4150 | 81 |
| 710 | M3BP 450LB 6 | 3GBP453520-••G | 995 | 96,9 | 97,0 | 96,5 | 0,85 | 1244 | 7,0 | 6814 | 1,3 | 2,5 | 37,0 | 4500 | 81 |
| 800 | ¹⁾ M3BP 450LC 6 | 3GBP453530-••G | 995 | 96,9 | 96,9 | 96,4 | 0,84 | 1415 | 7,2 | 7677 | 1,3 | 2,7 | 41,0 | 4800 | 81 |

¹⁾ Temperature rise class F

Technical data

IE2 cast iron motors, 1000 r/min

IP 55 - IC 411 - Insulation class F, temperature rise class B
IE2 efficiency class according to IEC 60034-30-1; 2014

| Output kW | Motor type | Product code | Speed r/min | Efficiency IEC 60034-30-1; 2014 | | | Power factor $\cos\phi$ | Current Torque | | | | | Moment of inertia $J = 1/4 \text{ GD}^2 \text{ kgm}^2$ | Weight kg | Sound pressure Level L_{PA} dB |
|-----------------------------|---------------|----------------|-------------|---------------------------------|--------------|--------------|-------------------------|---------------------------|-----------|----------|-----------|-----------|--------------------------------------------------------|-----------|----------------------------------|
| | | | | Full load 100% | 3/4 load 75% | 1/2 load 50% | | I_N A | I_s/I_N | T_N Nm | T_f/T_N | T_b/T_N | | | |
| 1000 r/min = 6 poles | | | | 400 V 50 Hz | | | | High-output design | | | | | | | |
| 15 | M3BP 160MLC 6 | 3GBP163430-••G | 971 | 89,7 | 91,2 | 91,2 | 0,77 | 31,3 | 7,3 | 147 | 1,8 | 3,6 | 0,131 | 185 | 59 |
| 18.5 | M3BP 180MLB 6 | 3GBP183420-••G | 975 | 90,7 | 92,0 | 92,0 | 0,79 | 37,2 | 5,8 | 181 | 1,7 | 2,7 | 0,198 | 221 | 59 |
| 30 ¹⁾ | M3BP 200MLC 6 | 3GBP203430-••G | 985 | 92,0 | 93,1 | 92,8 | 0,83 | 56,7 | 6,9 | 290 | 2,3 | 2,8 | 0,531 | 318 | 63 |
| 37 | M3BP 225SMB 6 | 3GBP223220-••G | 985 | 93,1 | 94,0 | 94,0 | 0,83 | 69,1 | 6,6 | 358 | 2,3 | 2,6 | 0,821 | 393 | 63 |
| 45 ¹⁾ | M3BP 225SMC 6 | 3GBP223230-••G | 984 | 92,7 | 93,9 | 94,0 | 0,83 | 84,4 | 6,4 | 436 | 2,3 | 2,6 | 0,821 | 393 | 63 |
| 45 | M3BP 250SMB 6 | 3GBP253220-••G | 989 | 93,4 | 94,1 | 93,9 | 0,83 | 83,7 | 7,0 | 434 | 2,5 | 2,7 | 1,37 | 441 | 63 |
| 55 ¹⁾ | M3BP 250SMC 6 | 3GBP253230-••G | 988 | 93,2 | 94,1 | 94,0 | 0,84 | 101 | 7,1 | 531 | 2,6 | 2,8 | 1,50 | 468 | 63 |
| 75 | M3BP 280SMC 6 | 3GBP283230-••G | 990 | 94,2 | 94,7 | 94,5 | 0,84 | 137 | 7,3 | 723 | 2,8 | 2,7 | 2,85 | 725 | 66 |
| 90 | M3BP 280MLA 6 | 3GBP283410-••G | 990 | 94,1 | 94,3 | 93,7 | 0,81 | 170 | 7,1 | 868 | 2,4 | 2,5 | 3,10 | 840 | 70 |
| 110 | M3BP 280MLB 6 | 3GBP283420-••G | 990 | 94,5 | 94,8 | 94,4 | 0,82 | 205 | 7,5 | 1061 | 2,7 | 2,6 | 4,10 | 890 | 70 |
| 160 | M3BP 315LKA 6 | 3GBP313810-••G | 992 | 95,3 | 95,3 | 94,7 | 0,83 | 291 | 7,5 | 1540 | 2,6 | 2,8 | 7,30 | 1410 | 74 |
| 180 | M3BP 315LKB 6 | 3GBP313820-••G | 992 | 95,3 | 95,4 | 94,8 | 0,83 | 328 | 7,4 | 1732 | 2,6 | 2,8 | 8,30 | 1520 | 74 |
| 200 | M3BP 315LKC 6 | 3GBP313830-••G | 989 | 95,4 | 95,6 | 95,3 | 0,85 | 360 | 6,8 | 1931 | 2,5 | 2,6 | 9,20 | 1600 | 74 |

¹⁾Temperature rise class F

Technical data

Cast iron motors, 750 r/min

IP 55 - IC 411 - Insulation class F, temperature rise class B
Efficiency class according to IEC 60034-30-1; 2014

| Output kW | Motor type | Product code | Speed r/min | Efficiency IEC 60034-30-1; 2014 | | | Power factor Cosφ | Current Torque | | | | | Moment of inertia J = 1/4 GD ² kgm ² | Weight kg | Sound pressure Level L _{PA} dB |
|----------------------------|-----------------------------|----------------|-------------|---------------------------------|--------------|--------------|-------------------|-----------------------|--------------------------------|-------------------|--------------------------------|--------------------------------|------------------------------------------------------------|-----------|-----------------------------------------|
| | | | | Full load 100% | 3/4 load 75% | 1/2 load 50% | | I _N A | I _s /I _N | T _N Nm | T _f /T _N | T _b /T _N | | | |
| 750 r/min = 8 poles | | | | 400 V 50 Hz | | | | CENELEC-design | | | | | | | |
| 0.09 | M3BP 71MA 8 | 3GBP074101-••B | 660 | 49,4 | 46,4 | 39,7 | 0,60 | 0,4 | 2,7 | 1,3 | 2,0 | 2,5 | 0,000890 | 11 | 40 |
| 0.12 | M3BP 71MB 8 | 3GBP074102-••B | 670 | 51,5 | 47,6 | 40,0 | 0,56 | 0,6 | 2,7 | 1,7 | 2,0 | 2,5 | 0,00110 | 12 | 43 |
| 0.18 | M3BP 80MA 8 | 3GBP084101-••B | 700 | 57,4 | 53,7 | 46,1 | 0,62 | 0,8 | 3,2 | 2,5 | 2,1 | 2,8 | 0,00187 | 15 | 45 |
| 0.25 | M3BP 80MB 8 | 3GBP084102-••B | 680 | 61,5 | 61,3 | 53,5 | 0,65 | 0,9 | 3,1 | 3,5 | 1,9 | 2,6 | 0,00239 | 17 | 50 |
| 0.37 | M3BP 90SLB 8 | 3GBP094102-••B | 705 | 66,3 | 64,0 | 57,0 | 0,54 | 1,4 | 2,8 | 5,0 | 1,9 | 2,5 | 0,00444 | 24 | 50 |
| 0.55 | M3BP 90SLC 8 | 3GBP094103-••B | 655 | 61,8 | 65,6 | 65,2 | 0,67 | 1,9 | 2,6 | 8,0 | 1,4 | 1,9 | 0,00491 | 25 | 53 |
| 0.75 | M3BP 100LA 8 | 3GBP104101-••B | 710 | 74,0 | 72,3 | 67,1 | 0,61 | 2,5 | 3,7 | 10,1 | 1,8 | 2,6 | 0,00720 | 30 | 46 |
| 1.1 | M3BP 100LB 8 | 3GBP104102-••B | 695 | 76,0 | 76,4 | 74,5 | 0,66 | 3,1 | 3,6 | 15,1 | 1,6 | 2,3 | 0,00871 | 30 | 53 |
| 1.5 | M3BP 112M 8 | 3GBP114101-••B | 690 | 74,4 | 75,9 | 74,1 | 0,74 | 4,1 | 3,5 | 20,9 | 1,9 | 2,6 | 0,0106 | 39 | 55 |
| 2.2 | M3BP 132SMA 8 | 3GBP134101-••B | 715 | 79,7 | 79,5 | 77,1 | 0,66 | 6,5 | 4,7 | 29,2 | 1,6 | 2,8 | 0,0334 | 70 | 56 |
| 3 | M3BP 132SMB 8 | 3GBP134102-••B | 715 | 79,9 | 79,7 | 76,6 | 0,64 | 8,5 | 4,7 | 39,7 | 1,7 | 2,8 | 0,040 | 75 | 58 |
| 4 | M3BP 160MLA 8 | 3GBP164410-••G | 728 | 84,0 | 85,1 | 83,6 | 0,67 | 10,2 | 5,4 | 52,4 | 1,5 | 2,6 | 0,068 | 120 | 59 |
| 5.5 | M3BP 160MLB 8 | 3GBP164420-••G | 726 | 84,6 | 85,9 | 84,8 | 0,67 | 13,9 | 5,6 | 72,3 | 1,4 | 2,6 | 0,085 | 134 | 59 |
| 7.5 | M3BP 160MLC 8 | 3GBP164430-••G | 727 | 86,0 | 87,3 | 86,5 | 0,65 | 19,3 | 4,7 | 98,5 | 1,5 | 2,8 | 0,132 | 184 | 59 |
| 11 | M3BP 180MLA 8 | 3GBP184410-••G | 731 | 86,7 | 88,3 | 87,8 | 0,67 | 27,3 | 4,4 | 143 | 1,8 | 2,6 | 0,214 | 233 | 59 |
| 15 | ¹⁾ M3BP 200MLA 8 | 3GBP204410-••G | 737 | 89,5 | 90,8 | 90,3 | 0,74 | 32,4 | 5,3 | 194 | 2,0 | 2,4 | 0,450 | 290 | 60 |
| 18.5 | M3BP 225SMA 8 | 3GBP224210-••G | 739 | 90,0 | 91,1 | 90,6 | 0,73 | 40,1 | 5,2 | 239 | 2,0 | 2,3 | 0,669 | 350 | 63 |
| 22 | M3BP 225SMB 8 | 3GBP224220-••G | 738 | 90,5 | 91,4 | 91,0 | 0,74 | 46,8 | 5,5 | 284 | 2,0 | 2,3 | 0,722 | 363 | 63 |
| 30 | M3BP 250SMA 8 | 3GBP254210-••G | 742 | 91,2 | 91,8 | 91,1 | 0,71 | 66,0 | 5,8 | 386 | 2,6 | 2,4 | 1,40 | 440 | 63 |
| 37 | M3BP 280SMA 8 | 3GBP284210-••G | 742 | 92,7 | 92,9 | 92,2 | 0,79 | 72,6 | 7,3 | 476 | 1,7 | 3,0 | 1,85 | 605 | 65 |
| 45 | M3BP 280SMB 8 | 3GBP284220-••G | 741 | 93,2 | 93,4 | 92,8 | 0,78 | 89,2 | 7,6 | 579 | 1,8 | 3,1 | 2,20 | 645 | 65 |
| 55 | M3BP 315SMA 8 | 3GBP314210-••G | 742 | 93,4 | 93,9 | 93,4 | 0,79 | 106 | 7,1 | 707 | 1,6 | 2,7 | 3,20 | 830 | 62 |
| 75 | M3BP 315SMB 8 | 3GBP314220-••G | 741 | 93,7 | 93,8 | 93,7 | 0,82 | 146 | 7,1 | 966 | 1,7 | 2,7 | 4,10 | 930 | 62 |
| 90 | M3BP 315SMC 8 | 3GBP314230-••G | 741 | 94,0 | 94,3 | 94,0 | 0,82 | 170 | 7,4 | 1159 | 1,8 | 2,7 | 4,90 | 1000 | 64 |
| 110 | M3BP 315MLA 8 | 3GBP314410-••G | 740 | 94,0 | 94,2 | 94,3 | 0,83 | 211 | 7,3 | 1419 | 1,8 | 2,7 | 5,80 | 1150 | 72 |
| 132 | M3BP 355SMA 8 | 3GBP354210-••G | 744 | 94,7 | 94,6 | 94,2 | 0,80 | 256 | 7,5 | 1694 | 1,5 | 2,6 | 7,90 | 1520 | 69 |
| 160 | M3BP 355SMB 8 | 3GBP354220-••G | 744 | 95,2 | 95,2 | 94,8 | 0,77 | 293 | 7,6 | 1926 | 1,6 | 2,6 | 9,70 | 1680 | 69 |
| 200 | M3BP 355SMC 8 | 3GBP354230-••G | 742 | 95,3 | 95,7 | 95,5 | 0,79 | 385 | 7,4 | 2576 | 1,6 | 2,6 | 11,3 | 1820 | 69 |
| 250 | M3BP 355MLB 8 | 3GBP354420-••G | 743 | 95,4 | 95,5 | 95,0 | 0,80 | 472 | 7,5 | 3213 | 1,6 | 2,7 | 13,5 | 2180 | 72 |
| 315 | M3BP 400LA 8 | 3GBP404510-••G | 743 | 96,1 | 96,0 | 95,6 | 0,81 | 592 | 7,0 | 4043 | 1,2 | 2,6 | 17,0 | 2900 | 71 |
| 315 | ¹⁾ M3BP 355LKB 8 | 3GBP354820-••G | 742 | 95,5 | 95,7 | 95,2 | 0,80 | 595 | 7,9 | 4053 | 1,7 | 2,7 | 16,5 | 2600 | 75 |
| 355 | M3BP 400LB 8 | 3GBP404520-••G | 743 | 96,2 | 96,3 | 96,1 | 0,83 | 641 | 6,8 | 4562 | 1,2 | 2,5 | 21,0 | 3200 | 71 |
| 400 | M3BP 400LC 8 | 3GBP404530-••G | 744 | 96,3 | 96,4 | 96,1 | 0,82 | 735 | 7,4 | 5134 | 1,3 | 2,7 | 24,0 | 3400 | 71 |
| 450 | M3BP 450LA 8 | 3GBP454510-••G | 744 | 96,2 | 96,5 | 96,2 | 0,83 | 813 | 6,0 | 5775 | 1,0 | 2,5 | 26,0 | 3750 | 80 |
| 500 | M3BP 450LB 8 | 3GBP454520-••G | 744 | 96,3 | 96,4 | 96,2 | 0,83 | 902 | 6,4 | 6417 | 1,0 | 2,6 | 29,0 | 4000 | 80 |
| 560 | M3BP 450LC 8 | 3GBP454530-••G | 744 | 96,4 | 96,5 | 96,1 | 0,82 | 1038 | 7,0 | 7188 | 1,2 | 2,9 | 35,0 | 4350 | 80 |
| 630 | ¹⁾ M3BP 450LD 8 | 3GBP454540-••G | 745 | 96,6 | 96,7 | 96,2 | 0,81 | 1162 | 7,6 | 8075 | 1,3 | 3,2 | 41,0 | 4800 | 80 |

¹⁾ Temperature rise class F

Technical data

Cast iron motors, 750 r/min

IP 55 - IC 411 - Insulation class F, temperature rise class B
Efficiency class according to IEC 60034-30-1; 2014

| Output kW | Motor type | Product code | Speed r/min | Efficiency IEC 60034-30-1; 2014 | | | Power factor $\cos\phi$ | Current Torque | | | | | Moment of inertia $J = 1/4$ GD^2/kgm^2 | Weight kg | Sound pressure Level L_{PA} dB |
|----------------------------|---------------|----------------|-------------|---------------------------------|--------------|--------------|-------------------------|---------------------------|-----------|----------|-----------|-----------|------------------------------------------|-----------|----------------------------------|
| | | | | Full load 100% | 3/4 load 75% | 1/2 load 50% | | I_N A | I_s/I_N | T_N Nm | T_f/T_N | T_b/T_N | | | |
| 750 r/min = 8 poles | | | | 400 V 50 Hz | | | | High-output design | | | | | | | |
| 18.5 | M3BP 200MLB 8 | 3GBP204420-••G | 739 | 90,0 | 90,8 | 90,2 | 0,74 | 40,0 | 5,4 | 239 | 2,1 | 2,3 | 0,530 | 318 | 60 |
| 30 | M3BP 225SMC 8 | 3GBP224230-••G | 737 | 91,2 | 92,3 | 92,1 | 0,73 | 64,7 | 5,6 | 388 | 2,3 | 2,4 | 0,828 | 393 | 63 |
| 37 | M3BP 250SMB 8 | 3GBP254220-••G | 740 | 91,7 | 92,8 | 92,5 | 0,73 | 78,9 | 5,4 | 477 | 2,6 | 2,3 | 1,51 | 468 | 63 |
| 45 ¹⁾ | M3BP 250SMC 8 | 3GBP254230-••G | 738 | 92,1 | 93,4 | 93,4 | 0,74 | 95,1 | 5,6 | 582 | 2,3 | 2,4 | 1,51 | 468 | 63 |
| 55 | M3BP 280SMC 8 | 3GBP284230-••G | 741 | 93,4 | 93,7 | 93,6 | 0,80 | 107 | 7,9 | 708 | 1,9 | 3,1 | 2,85 | 725 | 65 |
| 75 | M3BP 280MLB 8 | 3GBP284420-••G | 739 | 93,7 | 93,9 | 93,3 | 0,80 | 144 | 6,7 | 969 | 1,7 | 2,6 | 4,10 | 890 | 72 |
| 132 | M3BP 315LKA 8 | 3GBP314810-••G | 740 | 94,1 | 94,4 | 94,2 | 0,83 | 243 | 7,3 | 1703 | 1,8 | 2,6 | 7,30 | 1410 | 74 |
| 150 ¹⁾ | M3BP 315LKB 8 | 3GBP314820-••G | 741 | 94,1 | 94,7 | 94,6 | 0,83 | 278 | 7,7 | 1938 | 1,9 | 2,7 | 8,30 | 1520 | 74 |
| 160 ¹⁾ | M3BP 315LKC 8 | 3GBP314830-••G | 739 | 94,2 | 94,7 | 94,7 | 0,83 | 297 | 7,7 | 2068 | 1,9 | 2,8 | 9,20 | 1600 | 74 |

¹⁾ Temperature rise class F

Technical data

Cast iron motors, 600 and 500 r/min

IP 55 - IC 411 - Insulation class F, temperature rise class B
efficiency class according to IEC 60034-30-1; 2014

| Output kW | Motor type | Product code | Speed r/min | Efficiency IEC 60034-30-1; 2014 | | | Power factor Cosφ | Current Torque | | | | | Moment of inertia J = 1/4 GD ² kgm ² | Weight kg | Sound pressure Level L _{PA} dB |
|-----------------------------|----------------|----------------|--------------------|---------------------------------|--------------|-----------------------|-------------------|------------------|--------------------------------|-------------------|--------------------------------|--------------------------------|------------------------------------------------------------|-----------|-----------------------------------------|
| | | | | Full load 100% | 3/4 load 75% | 1/2 load 50% | | I _N A | I _s /I _N | T _N Nm | T _f /T _N | T _b /T _N | | | |
| 600 r/min = 10 poles | | | 400 V 50 Hz | | | CENELEC-design | | | | | | | | | |
| 37 | M3BP 280SMB 10 | 3GBP285220-••G | 593 | 92,5 | 92,3 | 90,9 | 0,73 | 79,0 | 6,6 | 595 | 1,6 | 3,0 | 2,20 | 645 | 60 |
| 45 | M3BP 280SMC 10 | 3GBP285230-••G | 592 | 93,0 | 92,9 | 91,7 | 0,75 | 93,1 | 6,7 | 725 | 1,6 | 2,8 | 2,85 | 725 | 60 |
| 55 | M3BP 315SMB 10 | 3GBP315220-••G | 594 | 93,8 | 93,8 | 92,9 | 0,78 | 108 | 6,7 | 884 | 1,6 | 2,7 | 4,10 | 930 | 70 |
| 75 | M3BP 315SMC 10 | 3GBP315230-••G | 593 | 93,6 | 93,7 | 92,8 | 0,78 | 148 | 6,6 | 1207 | 1,5 | 2,8 | 4,90 | 1000 | 70 |
| 90 | M3BP 315MLA 10 | 3GBP315410-••G | 593 | 93,7 | 93,8 | 93,0 | 0,78 | 177 | 6,6 | 1449 | 1,7 | 2,7 | 5,80 | 1150 | 70 |
| 110 | M3BP 355SMA 10 | 3GBP355210-••G | 595 | 94,5 | 94,5 | 93,6 | 0,76 | 221 | 6,6 | 1765 | 1,3 | 2,5 | 7,90 | 1520 | 73 |
| 132 | M3BP 355SMB 10 | 3GBP355220-••G | 594 | 94,8 | 94,9 | 94,2 | 0,79 | 254 | 6,6 | 2122 | 1,3 | 2,4 | 9,70 | 1680 | 73 |
| 160 | M3BP 355SMC 10 | 3GBP355230-••G | 594 | 94,8 | 94,9 | 94,2 | 0,77 | 316 | 6,9 | 2572 | 1,4 | 2,5 | 11,3 | 1820 | 76 |
| 200 | M3BP 355MLB 10 | 3GBP355420-••G | 594 | 95,0 | 95,1 | 94,5 | 0,78 | 389 | 6,5 | 3215 | 1,4 | 2,4 | 13,5 | 2180 | 77 |
| 250 ¹⁾ | M3BP 355LKB 10 | 3GBP355820-••G | 593 | 95,1 | 95,3 | 94,8 | 0,78 | 486 | 6,3 | 4025 | 1,4 | 2,3 | 16,5 | 2600 | 79 |
| 250 | M3BP 400LB 10 | 3GBP405520-••G | 595 | 95,3 | 95,3 | 94,5 | 0,74 | 511 | 6,2 | 4012 | 1,3 | 2,3 | 20,0 | 3100 | 79 |
| 315 | M3BP 400LC 10 | 3GBP405530-••G | 595 | 95,4 | 95,4 | 94,7 | 0,74 | 644 | 6,2 | 5055 | 1,3 | 2,3 | 24,0 | 3400 | 79 |
| 355 | M3BP 450LA 10 | 3GBP455510-••G | 596 | 95,9 | 95,9 | 95,2 | 0,72 | 742 | 5,8 | 5687 | 1,1 | 2,2 | 31,0 | 4050 | 82 |
| 355 | M3BP 450LB 10 | 3GBP455520-••G | 596 | 95,3 | 95,2 | 94,3 | 0,71 | 757 | 6,3 | 5687 | 1,1 | 2,3 | 34,0 | 4250 | 82 |
| 400 | M3BP 450LB 10 | 3GBP455520-••G | 596 | 95,9 | 95,9 | 95,1 | 0,72 | 836 | 5,7 | 6408 | 1,0 | 2,1 | 34,0 | 4250 | 82 |
| 400 | M3BP 450LC 10 | 3GBP455530-••G | 596 | 95,4 | 95,3 | 94,5 | 0,72 | 840 | 6,4 | 6408 | 1,1 | 2,4 | 38,0 | 4550 | 82 |
| 450 | M3BP 450LC 10 | 3GBP455530-••G | 596 | 96,1 | 96,1 | 95,4 | 0,73 | 925 | 5,8 | 7210 | 1,0 | 2,1 | 38,0 | 4550 | 82 |
| 450 | M3BP 450LD 10 | 3GBP455540-••G | 596 | 95,4 | 95,3 | 94,4 | 0,70 | 972 | 6,4 | 7210 | 1,2 | 2,4 | 42,0 | 4800 | 82 |
| 500 ¹⁾ | M3BP 450LD 10 | 3GBP455540-••G | 596 | 96,1 | 96,1 | 95,4 | 0,71 | 1057 | 5,9 | 8011 | 1,1 | 2,2 | 42,0 | 4800 | 82 |

| Output kW | Motor type | Product code | Speed r/min | Efficiency IEC 60034-30-1; 2014 | | | Power factor Cosφ | Current Torque | | | | | Moment of inertia J = 1/4 GD ² kgm ² | Weight kg | Sound pressure Level L _{PA} dB |
|-----------------------------|----------------|----------------|--------------------|---------------------------------|--------------|-----------------------|-------------------|------------------|--------------------------------|-------------------|--------------------------------|--------------------------------|------------------------------------------------------------|-----------|-----------------------------------------|
| | | | | Full load 100% | 3/4 load 75% | 1/2 load 50% | | I _N A | I _s /I _N | T _N Nm | T _f /T _N | T _b /T _N | | | |
| 500 r/min = 12 poles | | | 400 V 50 Hz | | | CENELEC-design | | | | | | | | | |
| 30 | M3BP 280SMB 12 | 3GBP286220-••G | 493 | 90,2 | 89,5 | 86,9 | 0,59 | 81,3 | 5,8 | 581 | 1,9 | 3,0 | 2,20 | 645 | 71 |
| 37 | M3BP 280SMC 12 | 3GBP286230-••G | 493 | 90,6 | 89,8 | 87,2 | 0,58 | 101 | 6,3 | 716 | 2,0 | 3,2 | 2,85 | 725 | 71 |
| 45 | M3BP 315SMB 12 | 3GBP316220-••G | 494 | 92,8 | 92,9 | 92,0 | 0,76 | 92,0 | 6,5 | 869 | 1,6 | 2,6 | 4,10 | 930 | 71 |
| 55 | M3BP 315SMC 12 | 3GBP316230-••G | 493 | 93,0 | 93,2 | 92,4 | 0,77 | 110 | 6,5 | 1065 | 1,6 | 2,6 | 4,90 | 1000 | 71 |
| 75 | M3BP 315MLA 12 | 3GBP316410-••G | 493 | 93,2 | 93,4 | 92,8 | 0,76 | 152 | 6,3 | 1462 | 1,5 | 2,5 | 5,80 | 1150 | 71 |
| 90 | M3BP 355SMA 12 | 3GBP356210-••G | 495 | 93,5 | 93,5 | 92,5 | 0,72 | 192 | 5,7 | 1736 | 1,3 | 2,4 | 7,90 | 1520 | 75 |
| 110 | M3BP 355SMB 12 | 3GBP356220-••G | 495 | 93,8 | 93,8 | 92,7 | 0,71 | 238 | 6,0 | 2122 | 1,4 | 2,5 | 9,70 | 1680 | 75 |
| 132 | M3BP 355SMC 12 | 3GBP356230-••G | 495 | 93,9 | 93,9 | 92,9 | 0,71 | 285 | 6,0 | 2546 | 1,4 | 2,5 | 11,3 | 1820 | 77 |
| 160 | M3BP 355MLB 12 | 3GBP356420-••G | 494 | 93,8 | 94,0 | 93,3 | 0,74 | 332 | 5,7 | 3092 | 1,3 | 2,4 | 13,5 | 2180 | 77 |
| 200 ¹⁾ | M3BP 355LKB 12 | 3GBP356820-••G | 494 | 93,9 | 94,1 | 93,4 | 0,73 | 421 | 5,8 | 3866 | 1,4 | 2,4 | 16,5 | 2600 | 79 |
| 200 | M3BP 400LB 12 | 3GBP406520-••G | 495 | 95,0 | 95,0 | 94,3 | 0,79 | 384 | 5,4 | 3858 | 1,1 | 2,2 | 20,0 | 3100 | 82 |
| 250 | M3BP 400LC 12 | 3GBP406530-••G | 495 | 95,2 | 95,2 | 94,5 | 0,79 | 479 | 5,7 | 4822 | 1,1 | 2,2 | 24,0 | 3400 | 82 |
| 315 | M3BP 450LB 12 | 3GBP456520-••G | 496 | 95,6 | 95,6 | 94,8 | 0,76 | 625 | 5,5 | 6064 | 1,0 | 2,1 | 34,0 | 4300 | 82 |
| 355 | M3BP 450LC 12 | 3GBP456530-••G | 495 | 95,6 | 95,6 | 95,0 | 0,76 | 705 | 5,3 | 6848 | 1,0 | 2,0 | 38,0 | 4550 | 82 |
| 400 ¹⁾ | M3BP 450LD 12 | 3GBP456540-••G | 495 | 95,7 | 95,8 | 95,2 | 0,77 | 783 | 5,3 | 7716 | 1,0 | 2,0 | 42,0 | 4800 | 82 |

¹⁾ Temperature rise class F

Technical data

IE3 cast iron motors, 3000 r/min

IP 55 - IC 411 - Insulation class F, temperature rise class B
IE3 efficiency class according to IEC 60034-30-1; 2014

| Output kW | Motor type | Product code | Speed r/min | Efficiency IEC 60034-30-1; 2014 | | | Power factor Cos ϕ | Current Torque | | | | | Moment of inertia J = 1/4 GD ² kgm ² | Weight kg | Sound pressure Level L _{PA} dB |
|-----------------------------|-----------------------------|----------------|-------------|---------------------------------|--------------|--------------|-------------------------|-----------------------|--------------------------------|-------------------|--------------------------------|--------------------------------|------------------------------------------------------------|-----------|-----------------------------------------|
| | | | | Full load 100% | 3/4 load 75% | 1/2 load 50% | | I _N A | I _S /I _N | T _N Nm | T _f /T _N | T _b /T _N | | | |
| 3000 r/min = 2 poles | | | | 400 V 50 Hz | | | | CENELEC-design | | | | | | | |
| 0.37 | M3BP 71MC 2 | 3GBP071330-●●L | 2743 | 73,8 | 74,4 | 71,7 | 0,76 | 0,94 | 4,9 | 1,26 | 2,3 | 2,8 | 0,00088 | 10 | 58 |
| 0.55 | M3BP 71ME 2 | 3GBP071350-●●L | 2755 | 77,8 | 79,3 | 78,4 | 0,83 | 1,25 | 6,8 | 1,9 | 2,8 | 3,1 | 0,00045 | 11 | 56 |
| 0.75 | M3BP 80MC 2 | 3GBP081330-●●L | 2879 | 80,7 | 81,0 | 78,8 | 0,82 | 1,6 | 7,2 | 2,5 | 3,4 | 4,2 | 0,0010 | 17 | 57 |
| 1.1 | M3BP 80ME 2 | 3GBP081350-●●L | 2865 | 82,7 | 83,8 | 83,1 | 0,84 | 2,3 | 7,2 | 3,7 | 3,5 | 4,1 | 0,00120 | 18 | 60 |
| 1.5 | M3BP 90SLA 2 | 3GBP091010-●●L | 2901 | 84,2 | 84,8 | 83,8 | 0,89 | 2,9 | 7,7 | 4,9 | 2,1 | 3,5 | 0,00280 | 27 | 69 |
| 2.2 | M3BP 90LA 2 | 3GBP091510-●●L | 2904 | 85,9 | 86,3 | 84,8 | 0,89 | 4,2 | 8,8 | 7,2 | 3,1 | 3,8 | 0,00360 | 30 | 64 |
| 3 | M3BP 100MLA 2 | 3GBP101410-●●L | 2895 | 87,1 | 87,9 | 87,3 | 0,92 | 5,4 | 8,2 | 9,9 | 3,3 | 3,9 | 0,00130 | 42 | 68 |
| 4 | M3BP 112ME 2 | 3GBP111350-●●L | 2882 | 88,1 | 89,9 | 90,9 | 0,93 | 6,9 | 8,3 | 13,0 | 2,9 | 3,7 | 0,0139 | 56 | 70 |
| 5.5 | M3BP 132SMC 2 | 3GBP131230-●●L | 2908 | 89,2 | 89,5 | 88,5 | 0,90 | 9,8 | 7,6 | 18,0 | 2,3 | 3,8 | 0,0182 | 69 | 70 |
| 7.5 | M3BP 132SME 2 | 3GBP131250-●●L | 2916 | 90,1 | 90,5 | 90,1 | 0,90 | 13,3 | 8,4 | 24,6 | 2,5 | 4,3 | 0,0203 | 75 | 70 |
| 11 | M3BP 160MLA 2 | 3GBP161410-●●L | 2943 | 91,2 | 92,0 | 91,6 | 0,91 | 19,1 | 7,2 | 35,6 | 2,6 | 3,6 | 0,0570 | 144 | 69 |
| 15 | M3BP 160MLB 2 | 3GBP161420-●●L | 2947 | 91,9 | 92,2 | 91,8 | 0,88 | 26,5 | 8,2 | 48,5 | 3,2 | 4,2 | 0,0630 | 152 | 69 |
| 18.5 | M3BP 160MLC 2 | 3GBP161430-●●L | 2949 | 92,4 | 93,0 | 92,6 | 0,90 | 32,0 | 9,0 | 59,8 | 3,3 | 3,9 | 0,0760 | 164 | 73 |
| 22 | M3BP 180MLA 2 | 3GBP181410-●●L | 2956 | 92,7 | 93,1 | 92,7 | 0,90 | 37,7 | 7,8 | 71,0 | 3,4 | 3,8 | 0,110 | 205 | 73 |
| 30 | M3BP 200MLA 2 | 3GBP201410-●●L | 2957 | 93,3 | 93,8 | 93,6 | 0,88 | 52,4 | 7,5 | 96,9 | 2,5 | 3,1 | 0,182 | 263 | 73 |
| 37 | M3BP 200MLB 2 | 3GBP201420-●●L | 2960 | 93,7 | 94,2 | 94,1 | 0,89 | 64,2 | 8,2 | 120 | 3,1 | 3,4 | 0,222 | 289 | 73 |
| 45 | M3BP 225SMA 2 | 3GBP221210-●●L | 2968 | 94,0 | 94,0 | 93,0 | 0,87 | 79,6 | 7,3 | 145 | 3,2 | 3,1 | 0,296 | 335 | 76 |
| 55 | M3BP 250SMA 2 | 3GBP251210-●●L | 2968 | 94,3 | 93,7 | 93,6 | 0,89 | 94,8 | 6,8 | 177 | 2,4 | 3,0 | 0,426 | 400 | 76 |
| 75 | M3BP 280SMB 2 | 3GBP281220-●●L | 2978 | 94,7 | 94,4 | 93,5 | 0,88 | 130 | 7,0 | 240 | 2,3 | 3,0 | 0,90 | 665 | 74 |
| 90 | M3BP 280SMC 2 | 3GBP281230-●●L | 2975 | 95,0 | 95,0 | 94,2 | 0,88 | 158 | 6,4 | 289 | 2,1 | 2,8 | 0,990 | 690 | 74 |
| 110 | M3BP 315SMB 2 | 3GBP311220-●●L | 2982 | 95,2 | 94,9 | 93,9 | 0,87 | 192 | 7,0 | 352 | 1,8 | 2,7 | 1,30 | 910 | 78 |
| 132 | M3BP 315SMC 2 | 3GBP311230-●●L | 2982 | 95,4 | 95,4 | 94,6 | 0,87 | 229 | 6,8 | 422 | 2,0 | 2,8 | 1,50 | 965 | 78 |
| 160 | M3BP 315SMD 2 | 3GBP311240-●●L | 2983 | 95,6 | 95,6 | 94,9 | 0,87 | 275 | 7,4 | 512 | 2,2 | 2,8 | 1,70 | 1025 | 78 |
| 200 | M3BP 315MLA 2 | 3GBP311410-●●L | 2983 | 95,8 | 95,8 | 95,3 | 0,88 | 342 | 7,7 | 640 | 2,5 | 3,1 | 2,10 | 1190 | 81 |
| 250 | ²⁾ M3BP 355SMA 2 | 3GBP351210-●●L | 2985 | 95,8 | 95,6 | 94,6 | 0,89 | 423 | 7,7 | 800 | 2,1 | 3,3 | 3,00 | 1600 | 83 |
| 315 | ²⁾ M3BP 355SMB 2 | 3GBP351220-●●L | 2980 | 95,8 | 95,7 | 95,0 | 0,89 | 529 | 7,0 | 1009 | 2,1 | 3,0 | 3,40 | 1680 | 83 |
| 355 | ²⁾ M3BP 355SMC 2 | 3GBP351230-●●L | 2984 | 95,8 | 95,8 | 95,0 | 0,88 | 605 | 7,2 | 1136 | 2,2 | 3,0 | 3,60 | 1750 | 83 |

| Output kW | Motor type | Product code | Speed r/min | Efficiency IEC 60034-30-1; 2014 | | | Power factor Cos ϕ | Current Torque | | | | | Moment of inertia J = 1/4 GD ² kgm ² | Weight kg | Sound pressure Level L _{PA} dB |
|-----------------------------|-----------------------------|----------------|-------------|---------------------------------|--------------|--------------|-------------------------|---------------------------|--------------------------------|-------------------|--------------------------------|--------------------------------|------------------------------------------------------------|-----------|-----------------------------------------|
| | | | | Full load 100% | 3/4 load 75% | 1/2 load 50% | | I _N A | I _S /I _N | T _N Nm | T _f /T _N | T _b /T _N | | | |
| 3000 r/min = 2 poles | | | | 400 V 50 Hz | | | | High-output design | | | | | | | |
| 22 | M3BP 160MLD 2 | 3GBP161440-●●L | 2944 | 92,7 | 93,5 | 93,5 | 0,90 | 38,0 | 8,4 | 71,4 | 3,2 | 3,7 | 0,0710 | 174 | 74 |
| 30 | M3BP 180MLB 2 | 3GBP181420-●●L | 2957 | 93,3 | 94,0 | 93,9 | 0,88 | 52,7 | 8,7 | 96,9 | 3,0 | 3,8 | 0,104 | 215 | 74 |
| 37 | M3BP 180MLC 2 | 3GBP181430-●●L | 2952 | 93,7 | 94,5 | 94,5 | 0,88 | 64,7 | 8,7 | 120 | 3,1 | 3,7 | 0,115 | 229 | 74 |
| 45 | M3BP 200MLC 2 | 3GBP201430-●●L | 2955 | 94,0 | 94,5 | 94,4 | 0,89 | 77,6 | 8,0 | 145 | 2,9 | 3,3 | 0,214 | 305 | 77 |
| 55 | M3BP 225SMB 2 | 3GBP221220-●●L | 2966 | 94,3 | 94,6 | 94,1 | 0,88 | 95,6 | 7,4 | 177 | 2,9 | 2,9 | 0,274 | 355 | 79 |
| 75 | M3BP 225SMC 2 | 3GBP221230-●●L | 2966 | 94,7 | 94,8 | 94,1 | 0,88 | 129 | 8,1 | 241 | 3,3 | 3,0 | 0,329 | 408 | 79 |
| 75 | M3BP 250SMB 2 | 3GBP251220-●●L | 2971 | 94,7 | 95,1 | 94,8 | 0,90 | 127 | 7,9 | 241 | 2,8 | 3,3 | 0,644 | 479 | 81 |
| 90 | ¹⁾ M3BP 250SMC 2 | 3GBP251230-●●L | 2968 | 95,0 | 95,4 | 95,0 | 0,90 | 151 | 8,4 | 290 | 2,7 | 3,4 | 0,644 | 495 | 81 |
| 110 | M3BP 280SMD 2 | 3GBP281240-●●L | 2977 | 95,2 | 95,2 | 94,4 | 0,88 | 190 | 7,5 | 353 | 2,4 | 3,1 | 1,150 | 725 | 75 |
| 250 | M3BP 315LKB 2 | 3GBP311820-●●L | 2983 | 95,8 | 96,0 | 95,5 | 0,90 | 419 | 7,7 | 800 | 2,5 | 3,3 | 2,90 | 1540 | 81 |

¹⁾ Temperature rise class F

²⁾ 3dB(A) sound pressure level reduction with unidirectional fan construction. Direction of rotation must be stated when ordering, see variant codes 044 and 045

Technical data

IE3 Cast iron motors, 3000 r/min

IP 55 - IC 411 - Insulation class F, temperature rise class B
IE3 efficiency class according to IEC 60034-30-1; 2014

| Output kW | Motor type | Product code | Speed r/min | Efficiency IEC 60034-30-1; 2014 | | | Power factor Cosφ | Current Torque | | | | | Moment of inertia J = 1/4 GD ² kgm ² | Weight kg | Sound pressure Level L _{PA} dB |
|-----------------------------|---------------|----------------|-------------|---------------------------------|--------------|--------------|-----------------------|------------------|--------------------------------|-------------------|--------------------------------|--------------------------------|------------------------------------------------------------|-----------|-----------------------------------------|
| | | | | Full load 100% | 3/4 load 75% | 1/2 load 50% | | I _N A | I _s /I _N | T _N Nm | T _f /T _N | T _b /T _N | | | |
| 3000 r/min = 2 poles | | | | 400 V 50 Hz | | | CENELEC-design | | | | | | | | |
| 0.75 | M3BP 80MD 2 | 3GBP081340-••K | 2872 | 82,1 | 82,5 | 80,9 | 0,87 | 1,51 | 6,2 | 2,43 | 2,9 | 3,4 | 0,0012 | 18 | 57 |
| 1.1 | M3BP 80MG 2 | 3GBP081370-••K | 2862 | 84,2 | 85,1 | 84,3 | 0,87 | 2,1 | 6,3 | 3,65 | 3 | 3,5 | 0,0014 | 19 | 60 |
| 1.5 | M3BP 90LB 2 | 3GBP091520-••K | 2892 | 86,4 | 87,4 | 86,7 | 0,89 | 2,7 | 7,3 | 4,8 | 2,0 | 3,2 | 0,00310 | 31 | 69 |
| 2.2 | M3BP 90LC 2 | 3GBP091530-••K | 2900 | 87,6 | 88,3 | 87,4 | 0,89 | 4,0 | 9,1 | 7,3 | 3,4 | 4,1 | 0,00440 | 35 | 64 |
| 3 | M3BP 100LKA 2 | 3GBP101810-••K | 2907 | 89,0 | 89,4 | 88,5 | 0,89 | 5,4 | 8,8 | 9,9 | 3,3 | 4,3 | 0,00860 | 50 | 68 |
| 4 | M3BP 112MG 2 | 3GBP111370-••K | 2882 | 88,4 | 89,9 | 90,5 | 0,93 | 7,0 | 8,1 | 13,3 | 2,8 | 4,1 | 0,0132 | 56 | 70 |
| 5.5 | M3BP 132SMF 2 | 3GBP131260-••K | 2902 | 90,7 | 91,3 | 91,0 | 0,90 | 9,7 | 7,3 | 18,2 | 2,7 | 4,2 | 0,0218 | 77 | 67 |
| 7.5 | M3BP 132SMG 2 | 3GBP131270-••K | 2907 | 91,3 | 92,1 | 92,1 | 0,90 | 13,2 | 8,1 | 24,7 | 3,2 | 4,7 | 0,0218 | 77 | 70 |
| 11 | M3BP 160MLA 2 | 3GBP161410-••K | 2943 | 92,1 | 92,7 | 92,4 | 0,92 | 18,7 | 8,1 | 35,6 | 2,7 | 3,4 | 0,0520 | 151 | 69 |
| 15 | M3BP 160MLB 2 | 3GBP161420-••K | 2943 | 92,5 | 93,4 | 93,2 | 0,92 | 25,4 | 8,4 | 48,6 | 3,1 | 3,4 | 0,0620 | 163 | 69 |
| 18.5 | M3BP 160MLC 2 | 3GBP161430-••K | 2942 | 93,1 | 93,9 | 93,9 | 0,93 | 30,8 | 8,3 | 60,0 | 3,1 | 3,6 | 0,0720 | 176 | 69 |
| 22 | M3BP 180MLA 2 | 3GBP181410-••K | 2957 | 93,2 | 93,9 | 93,8 | 0,91 | 37,4 | 8,1 | 71,0 | 2,6 | 3,2 | 0,116 | 230 | 69 |
| 30 | M3BP 200MLA 2 | 3GBP201410-••K | 2958 | 94,2 | 94,9 | 94,7 | 0,90 | 51,0 | 7,8 | 96,8 | 2,8 | 3,1 | 0,196 | 289 | 72 |
| 37 | M3BP 200MLB 2 | 3GBP201420-••K | 2960 | 94,7 | 95,2 | 95,0 | 0,91 | 61,9 | 8,8 | 119 | 3,1 | 3,4 | 0,217 | 301 | 72 |
| 45 | M3BP 225SMA 2 | 3GBP221210-••K | 2972 | 94,9 | 95,1 | 94,7 | 0,89 | 76,8 | 7,8 | 144 | 3,1 | 3,0 | 0,323 | 387 | 74 |
| 55 | M3BP 250SMA 2 | 3GBP251210-••K | 2975 | 95,2 | 95,4 | 95,0 | 0,89 | 93,6 | 8,0 | 176 | 2,8 | 3,3 | 0,579 | 439 | 75 |
| 75 | M3BP 280SMB 2 | 3GBP281220-••K | 2980 | 95,5 | 95,5 | 94,9 | 0,87 | 129 | 7,3 | 240 | 2,1 | 2,9 | 0,90 | 665 | 77 |
| 90 | M3BP 280SMC 2 | 3GBP281230-••K | 2981 | 95,7 | 95,6 | 95,0 | 0,88 | 153 | 8,0 | 288 | 2,5 | 3,1 | 1,150 | 725 | 77 |
| 110 | M3BP 315SMB 2 | 3GBP311220-••K | 2982 | 95,9 | 95,9 | 95,2 | 0,88 | 189 | 6,7 | 352 | 1,9 | 2,6 | 1,40 | 940 | 77 |
| 132 | M3BP 315SMC 2 | 3GBP311230-••K | 2986 | 96,1 | 96,2 | 95,9 | 0,88 | 226 | 7,9 | 422 | 2,4 | 3,0 | 1,70 | 1025 | 77 |
| 160 | M3BP 315MLA 2 | 3GBP311410-••K | 2983 | 96,2 | 96,5 | 96,2 | 0,90 | 268 | 7,3 | 512 | 2,2 | 2,7 | 2,10 | 1190 | 77 |
| 200 ¹⁾ | M3BP 355SMA 2 | 3GBP351210-••K | 2985 | 96,4 | 96,1 | 95,3 | 0,89 | 336 | 7,6 | 640 | 2,0 | 3,1 | 3,00 | 1600 | 83 |
| 250 ¹⁾ | M3BP 355SMB 2 | 3GBP351220-••K | 2983 | 96,4 | 96,5 | 96,1 | 0,90 | 415 | 7,6 | 800 | 2,2 | 3,0 | 3,40 | 1680 | 83 |
| 315 ¹⁾ | M3BP 355SMC 2 | 3GBP351230-••K | 2984 | 96,4 | 96,4 | 95,9 | 0,89 | 533 | 7,8 | 1008 | 2,3 | 2,8 | 3,60 | 1750 | 83 |
| 355 | M3BP 355MLA 2 | 3GBP351410-••K | 2981 | 96,4 | 96,7 | 96,3 | 0,90 | 595 | 7,5 | 1137 | 2,3 | 2,6 | 4,10 | 2000 | 83 |

| Output kW | Motor type | Product code | Speed r/min | Efficiency IEC 60034-30-1; 2014 | | | Power factor Cosφ | Current Torque | | | | | Moment of inertia J = 1/4 GD ² kgm ² | Weight kg | Sound pressure Level L _{PA} dB |
|-----------------------------|---------------|----------------|-------------|---------------------------------|--------------|--------------|---------------------------|------------------|--------------------------------|-------------------|--------------------------------|--------------------------------|------------------------------------------------------------|-----------|-----------------------------------------|
| | | | | Full load 100% | 3/4 load 75% | 1/2 load 50% | | I _N A | I _s /I _N | T _N Nm | T _f /T _N | T _b /T _N | | | |
| 3000 r/min = 2 poles | | | | 400 V 50 Hz | | | High-output design | | | | | | | | |
| 200 | M3BP 315MLB 2 | 3GBP311420-••K | 2983 | 96,4 | 96,7 | 96,6 | 0,90 | 333 | 6,8 | 640 | 1,9 | 2,6 | 2,20 | 1220 | 77 |
| 250 | M3BP 315LKB 2 | 3GBP311820-••K | 2982 | 96,4 | 96,7 | 96,7 | 0,91 | 413 | 7,9 | 800 | 2,5 | 2,7 | 2,90 | 1540 | 77 |

¹⁾3dB(A) sound pressure level reduction with unidirectional fan construction. Direction of rotation must be stated when ordering, see variant codes 044 and 045

Technical data

IE3 cast iron motors, 1500 r/min

IP 55 - IC 411 - Insulation class F, temperature rise class B
IE3 efficiency class according to IEC 60034-30-1; 2014

| Output kW | Motor type | Product code | Speed r/min | Efficiency IEC 60034-30-1; 2014 | | | Power factor Cos ϕ | Current Torque | | | | | Moment of inertia J = 1/4 GD ² kgm ² | Weight kg | Sound pressure Level L _{PA} dB |
|-----------------------------|---------------|----------------|----------------|------------------------------------|--------------------|--------------------|-------------------------------|-----------------------|--------------------------------|----------------------|--------------------------------|--------------------------------|---------------------------------------------------------------------|--------------|--------------------------------------------------|
| | | | | Full load 100% | 3/4 load 75% | 1/2 load 50% | | I _N A | I _s /I _N | T _N Nm | T _f /T _N | T _v /T _N | | | |
| 1500 r/min = 4 poles | | | | 400 V 50 Hz | | | | CENELEC-design | | | | | | | |
| 0.25 | M3BP 71MD 4 | 3GBP072340-••L | 1416 | 73,5 | 75,1 | 73,8 | 0,8 | 0,6 | 4,8 | 1,68 | 2 | 2,6 | 0,0009 | 11 | 45 |
| 0.37 | M3BP 71MLE 4 | 3GBP072450-••L | 1432 | 77,3 | 77,4 | 74,5 | 0,76 | 0,9 | 5,8 | 2,46 | 2,7 | 3,3 | 0,00122 | 15 | 45 |
| 0.55 | M3BP 80MLC 4 | 3GBP082430-••L | 1444 | 80,8 | 81,6 | 80,1 | 0,8 | 1,2 | 6,7 | 4 | 3 | 3,5 | 0,0028 | 20 | 45 |
| 0.75 | M3BP 80MLC 4 | 3GBP082450-••L | 1448 | 82,5 | 82,5 | 80,1 | 0,78 | 1,7 | 7,4 | 4,9 | 3,5 | 4,0 | 0,00330 | 22 | 50 |
| 1.1 | M3BP 90LA 4 | 3GBP092510-••L | 1443 | 84,1 | 84,6 | 83,5 | 0,76 | 2,4 | 5,2 | 7,3 | 3,4 | 4,2 | 0,00490 | 28 | 56 |
| 1.5 | M3BP 90LB 4 | 3GBP092520-••L | 1445 | 85,3 | 85,0 | 82,6 | 0,77 | 3,3 | 5,7 | 9,9 | 3,8 | 4,6 | 0,00670 | 32 | 56 |
| 2.2 | M3BP 100LA 4 | 3GBP102510-••L | 1448 | 86,7 | 89,0 | 86,1 | 0,81 | 4,5 | 7,5 | 14,0 | 2,3 | 3,6 | 0,0109 | 38 | 56 |
| 3 | M3BP 100MLB 4 | 3GBP102420-••L | 1444 | 87,7 | 88,4 | 87,6 | 0,81 | 6,1 | 7,0 | 19,8 | 3,3 | 4,1 | 0,0121 | 42 | 58 |
| 4 | M3BP 112ME 4 | 3GBP112350-••L | 1453 | 88,6 | 88,9 | 88,0 | 0,74 | 8,9 | 7,8 | 26,0 | 3,5 | 4,3 | 0,0188 | 52 | 59 |
| 5.5 | M3BP 132SMB 4 | 3GBP132220-••L | 1463 | 89,6 | 89,8 | 88,7 | 0,74 | 11,9 | 7,6 | 36,0 | 2,8 | 3,9 | 0,0295 | 68 | 70 |
| 7.5 | M3BP 132SME 4 | 3GBP132250-••L | 1462 | 90,4 | 90,8 | 90,2 | 0,76 | 15,7 | 7,9 | 49,0 | 3,0 | 4,0 | 0,0376 | 78 | 64 |
| 11 | M3BP 160MLA 4 | 3GBP162410-••L | 1477 | 91,4 | 91,8 | 91,1 | 0,82 | 21,1 | 7,6 | 71,3 | 2,6 | 3,3 | 0,110 | 160 | 61 |
| 15 | M3BP 160MLB 4 | 3GBP162420-••L | 1477 | 92,1 | 92,4 | 91,6 | 0,82 | 28,5 | 8,2 | 97,0 | 3,0 | 3,7 | 0,135 | 179 | 61 |
| 18.5 | M3BP 180MLA 4 | 3GBP182410-••L | 1481 | 92,6 | 93,2 | 92,9 | 0,83 | 34,9 | 7,2 | 119 | 2,8 | 3,0 | 0,219 | 215 | 60 |
| 22 | M3BP 180MLB 4 | 3GBP182420-••L | 1481 | 93,0 | 93,5 | 93,3 | 0,82 | 41,4 | 6,5 | 142 | 3,0 | 3,2 | 0,243 | 229 | 60 |
| 30 | M3BP 200MLA 4 | 3GBP202410-••L | 1483 | 93,6 | 93,8 | 93,4 | 0,84 | 54,8 | 7,5 | 193 | 2,7 | 3,2 | 0,385 | 292 | 63 |
| 37 | M3BP 225SMA 4 | 3GBP222210-••L | 1482 | 93,9 | 94,1 | 93,8 | 0,83 | 68,9 | 7,2 | 239 | 3,1 | 3,1 | 0,427 | 322 | 67 |
| 45 | M3BP 225SMB 4 | 3GBP222220-••L | 1482 | 94,2 | 94,4 | 94,0 | 0,84 | 82,3 | 8,0 | 290 | 3,2 | 3,5 | 0,525 | 357 | 66 |
| 55 | M3BP 250SMA 4 | 3GBP252210-••L | 1482 | 94,6 | 94,7 | 94,0 | 0,84 | 100 | 7,1 | 354 | 2,9 | 3,4 | 0,694 | 406 | 68 |
| 75 | M3BP 280SMB 4 | 3GBP282220-••L | 1485 | 95,0 | 95,2 | 94,8 | 0,86 | 133 | 6,4 | 483 | 2,3 | 2,8 | 1,380 | 645 | 75 |
| 90 | M3BP 280SMC 4 | 3GBP282230-••L | 1485 | 95,2 | 95,5 | 95,2 | 0,86 | 158 | 7,1 | 578 | 2,5 | 2,9 | 1,730 | 700 | 75 |
| 110 | M3BP 315SMB 4 | 3GBP312220-••L | 1489 | 95,4 | 95,5 | 94,9 | 0,84 | 195 | 7,0 | 705 | 2,1 | 3,0 | 2,430 | 930 | 71 |
| 132 | M3BP 315SMC 4 | 3GBP312230-••L | 1488 | 95,6 | 95,9 | 95,5 | 0,86 | 231 | 6,7 | 847 | 2,2 | 2,9 | 2,90 | 1000 | 71 |
| 160 | M3BP 315SMD 4 | 3GBP312240-••L | 1488 | 95,8 | 96,0 | 95,8 | 0,85 | 282 | 6,9 | 1026 | 2,2 | 3,0 | 3,20 | 1065 | 71 |
| 200 | M3BP 315MLB 4 | 3GBP312420-••L | 1487 | 96,0 | 96,4 | 96,4 | 0,86 | 351 | 6,8 | 1284 | 2,4 | 3,0 | 3,90 | 1220 | 74 |
| 250 | M3BP 355SMA 4 | 3GBP352210-••L | 1491 | 96,0 | 96,0 | 95,6 | 0,86 | 435 | 6,4 | 1601 | 2,1 | 2,9 | 5,90 | 1610 | 78 |
| 315 | M3BP 355SMB 4 | 3GBP352220-••L | 1491 | 96,0 | 96,1 | 95,7 | 0,85 | 550 | 7,3 | 2018 | 2,4 | 3,3 | 6,90 | 1780 | 78 |
| 355 | M3BP 355SMC 4 | 3GBP352230-••L | 1490 | 96,0 | 96,2 | 95,8 | 0,86 | 616 | 6,3 | 2273 | 2,3 | 2,8 | 7,20 | 1820 | 78 |

| Output kW | Motor type | Product code | Speed r/min | Efficiency IEC 60034-30-1; 2014 | | | Power factor Cos ϕ | Current Torque | | | | | Moment of inertia J = 1/4 GD ² kgm ² | Weight kg | Sound pressure Level L _{PA} dB |
|-----------------------------|---------------|----------------|----------------|------------------------------------|--------------------|--------------------|-------------------------------|---------------------------|--------------------------------|----------------------|--------------------------------|--------------------------------|---------------------------------------------------------------------|--------------|--------------------------------------------------|
| | | | | Full load 100% | 3/4 load 75% | 1/2 load 50% | | I _N A | I _s /I _N | T _N Nm | T _f /T _N | T _v /T _N | | | |
| 1500 r/min = 4 poles | | | | 400 V 50 Hz | | | | High-output design | | | | | | | |
| 18,5 | M3BP 160MLC 4 | 3GBP162430-••L | 1473 | 92,6 | 93,3 | 93,1 | 0,82 | 35,1 | 8,3 | 120 | 3,1 | 3,5 | 0,124 | 180 | 67 |
| 37 | M3BP 200MLB 4 | 3GBP202420-••L | 1480 | 93,9 | 94,8 | 94,8 | 0,82 | 69,3 | 7,5 | 239 | 2,8 | 2,9 | 0,362 | 305 | 68 |
| 55 | M3BP 225SMC 4 | 3GBP222230-••L | 1478 | 94,6 | 94,9 | 94,8 | 0,84 | 99,9 | 7,7 | 355 | 3,3 | 3,3 | 0,536 | 391 | 71 |
| 75 | M3BP 250SMB 4 | 3GBP252220-••L | 1482 | 95,0 | 95,4 | 95,0 | 0,84 | 135 | 7,9 | 483 | 3,3 | 3,5 | 0,941 | 464 | 73 |
| 110 | M3BP 280SMD 4 | 3GBP282240-••L | 1486 | 95,4 | 95,7 | 95,3 | 0,85 | 196 | 7,3 | 707 | 2,7 | 3,0 | 1,950 | 750 | 76 |
| 132 | M3BP 280MLA 4 | 3GBP282410-••L | 1483 | 95,6 | 95,9 | 95,7 | 0,86 | 232 | 7,0 | 849 | 2,7 | 2,8 | 2,30 | 840 | 75 |
| 160 | M3BP 280MLB 4 | 3GBP282420-••L | 1484 | 95,8 | 96,0 | 95,8 | 0,86 | 280 | 7,4 | 1029 | 2,9 | 2,9 | 2,50 | 890 | 75 |
| 250 | M3BP 315LKA 4 | 3GBP312810-••L | 1488 | 96,0 | 96,3 | 96,1 | 0,85 | 442 | 6,9 | 1604 | 2,5 | 3,2 | 4,40 | 1410 | 78 |
| 280 | M3BP 315LKB 4 | 3GBP312820-••L | 1488 | 96,0 | 96,2 | 96,0 | 0,86 | 490 | 7,8 | 1797 | 2,7 | 3,1 | 5,00 | 1520 | 78 |
| 315 | M3BP 315LKC 4 | 3GBP312830-••L | 1489 | 96,0 | 96,1 | 95,8 | 0,85 | 557 | 8,3 | 2020 | 3,0 | 3,3 | 5,50 | 1600 | 78 |

Technical data

IE3 Cast iron motors, 1500 r/min

IP 55 - IC 411 - Insulation class F, temperature rise class B
IE3 efficiency class according to IEC 60034-30-1; 2014

| Output kW | Motor type | Product code | Speed r/min | Efficiency IEC 60034-30-1; 2014 | | | Power factor Cosφ | Current Torque | | | | | Moment of inertia J = 1/4 GD ² kgm ² | Weight kg | Sound pressure Level L _{PA} dB |
|-----------------------------|---------------|----------------|-------------|---------------------------------|--------------|--------------|-------------------|-----------------------|--------------------------------|-------------------|--------------------------------|--------------------------------|------------------------------------------------------------|-----------|-----------------------------------------|
| | | | | Full load 100% | 3/4 load 75% | 1/2 load 50% | | I _N A | I _s /I _N | T _N Nm | T _f /T _N | T _b /T _N | | | |
| 1500 r/min = 4 poles | | | | 400 V 50 Hz | | | | CENELEC-design | | | | | | | |
| 0.55 | M3BP 80MLD 4 | 3GBP082440-••K | 1439 | 82,9 | 84,2 | 83,5 | 0,81 | 1,18 | 6,3 | 3,6 | 2,7 | 3,3 | 0,0028 | 20 | 45 |
| 0.75 | M3BP 80MLG 4 | 3GBP082470-••K | 1445 | 84,1 | 85 | 83,8 | 0,79 | 1,62 | 7 | 4,97 | 3,1 | 3,8 | 0,0033 | 22 | 57 |
| 1.1 | M3BP 90LC 4 | 3GBP092530-••K | 1444 | 87,1 | 87,5 | 86,4 | 0,79 | 2,3 | 7,2 | 7,3 | 2,7 | 3,7 | 0,00670 | 33 | 56 |
| 1.5 | M3BP 90LD 4 | 3GBP092540-••K | 1442 | 87,1 | 88,1 | 87,6 | 0,78 | 3,1 | 7,8 | 10,0 | 3,4 | 4,5 | 0,00720 | 34 | 56 |
| 2.2 | M3BP 100LKA 4 | 3GBP102810-••K | 1452 | 89,4 | 90,3 | 90,2 | 0,83 | 4,2 | 7,4 | 14,5 | 2,2 | 3,9 | 0,0146 | 49 | 56 |
| 3 | M3BP 100LKB 4 | 3GBP102820-••K | 1452 | 89,4 | 90,5 | 90,5 | 0,83 | 5,8 | 7,5 | 19,7 | 2,3 | 4,0 | 0,0146 | 49 | 58 |
| 4 | M3BP 112MG 4 | 3GBP112370-••K | 1454 | 88,6 | 89,1 | 88,6 | 0,75 | 8,7 | 7,5 | 26,3 | 3,5 | 3,7 | 0,0176 | 52 | 1978 |
| 5.5 | M3BP 132SMF 4 | 3GBP132260-••K | 1462 | 90,7 | 91,6 | 91,6 | 0,81 | 10,8 | 7,3 | 35,9 | 2,4 | 3,4 | 0,0401 | 81 | 67 |
| 7.5 | M3BP 132SMG 4 | 3GBP132270-••K | 1457 | 90,4 | 91,5 | 91,7 | 0,81 | 14,8 | 7,3 | 49,1 | 2,4 | 3,4 | 0,0401 | 81 | 64 |
| 11 | M3BP 160MLA 4 | 3GBP162410-••K | 1473 | 92,2 | 93,0 | 92,7 | 0,84 | 20,4 | 7,7 | 71,3 | 2,6 | 2,9 | 0,108 | 165 | 62 |
| 15 | M3BP 160MLB 4 | 3GBP162420-••K | 1474 | 92,6 | 93,4 | 93,2 | 0,84 | 27,8 | 7,9 | 97,1 | 2,8 | 3,3 | 0,125 | 181 | 62 |
| 18.5 | M3BP 180MLA 4 | 3GBP182410-••K | 1481 | 93,3 | 94,0 | 93,8 | 0,82 | 34,9 | 7,6 | 119 | 3,0 | 3,1 | 0,217 | 224 | 62 |
| 22 | M3BP 180MLB 4 | 3GBP182420-••K | 1480 | 93,3 | 94,1 | 94,1 | 0,82 | 41,5 | 8,2 | 141 | 2,8 | 3,1 | 0,217 | 229 | 62 |
| 30 | M3BP 200MLA 4 | 3GBP202410-••K | 1484 | 94,4 | 94,8 | 94,6 | 0,84 | 54,6 | 8,3 | 193 | 3,0 | 3,3 | 0,366 | 299 | 63 |
| 37 | M3BP 225SMA 4 | 3GBP222210-••K | 1482 | 94,9 | 95,5 | 95,4 | 0,86 | 65,4 | 7,7 | 238 | 2,8 | 3,1 | 0,536 | 376 | 66 |
| 45 | M3BP 225SMB 4 | 3GBP222220-••K | 1482 | 95,2 | 95,6 | 95,5 | 0,85 | 80,2 | 7,9 | 289 | 2,8 | 3,2 | 0,536 | 377 | 66 |
| 55 | M3BP 250SMA 4 | 3GBP252210-••K | 1485 | 95,4 | 95,9 | 95,7 | 0,85 | 97,8 | 7,9 | 353 | 3,0 | 3,3 | 0,933 | 458 | 67 |
| 75 | M3BP 280SMB 4 | 3GBP282220-••K | 1486 | 95,9 | 96,2 | 96,1 | 0,85 | 134 | 7,4 | 482 | 2,5 | 2,8 | 1,50 | 665 | 72 |
| 90 | M3BP 280SMC 4 | 3GBP282230-••K | 1487 | 96,0 | 96,2 | 95,9 | 0,85 | 161 | 7,9 | 578 | 2,9 | 3,0 | 1,850 | 725 | 72 |
| 110 | M3BP 315SMC 4 | 3GBP312230-••K | 1491 | 96,2 | 96,5 | 96,1 | 0,85 | 194 | 7,8 | 704 | 2,4 | 3,1 | 2,90 | 1000 | 68 |
| 132 | M3BP 315SMD 4 | 3GBP312240-••K | 1490 | 96,3 | 96,6 | 96,2 | 0,85 | 234 | 7,9 | 846 | 2,6 | 3,2 | 3,20 | 1065 | 68 |
| 160 | M3BP 315MLB 4 | 3GBP312420-••K | 1490 | 96,5 | 96,7 | 96,4 | 0,87 | 278 | 7,9 | 1026 | 2,7 | 3,0 | 3,90 | 1220 | 68 |
| 200 | M3BP 355SMA 4 | 3GBP352210-••K | 1491 | 96,6 | 96,7 | 96,4 | 0,87 | 345 | 7,3 | 1282 | 2,1 | 2,7 | 5,90 | 1610 | 74 |
| 250 | M3BP 355SMB 4 | 3GBP352220-••K | 1491 | 96,6 | 96,8 | 96,5 | 0,87 | 433 | 7,8 | 1601 | 2,5 | 2,9 | 6,90 | 1780 | 74 |
| 315 | M3BP 355SMC 4 | 3GBP352230-••K | 1490 | 96,6 | 96,8 | 96,5 | 0,85 | 554 | 7,4 | 2017 | 2,8 | 2,9 | 7,20 | 1820 | 74 |
| 355 | M3BP 355MLA 4 | 3GBP352410-••K | 1491 | 96,6 | 96,9 | 96,5 | 0,87 | 616 | 7,9 | 2274 | 2,7 | 2,9 | 8,40 | 2140 | 78 |

| Output kW | Motor type | Product code | Speed r/min | Efficiency IEC 60034-30-1; 2014 | | | Power factor Cosφ | Current Torque | | | | | Moment of inertia J = 1/4 GD ² kgm ² | Weight kg | Sound pressure Level L _{PA} dB |
|-----------------------------|---------------|----------------|-------------|---------------------------------|--------------|--------------|-------------------|---------------------------|--------------------------------|-------------------|--------------------------------|--------------------------------|------------------------------------------------------------|-----------|-----------------------------------------|
| | | | | Full load 100% | 3/4 load 75% | 1/2 load 50% | | I _N A | I _s /I _N | T _N Nm | T _f /T _N | T _b /T _N | | | |
| 1500 r/min = 4 poles | | | | 400 V 50 Hz | | | | High-output design | | | | | | | |
| 200 | M3BP 315LKB 4 | 3GBP312820-••K | 1490 | 96,6 | 96,8 | 96,7 | 0,87 | 346 | 7,6 | 1282 | 2,5 | 2,9 | 5,00 | 1520 | 74 |
| 250 | M3BP 315LKC 4 | 3GBP312830-••K | 1490 | 96,6 | 96,9 | 96,8 | 0,87 | 432 | 7,8 | 1601 | 2,3 | 3,0 | 5,50 | 1600 | 74 |

Technical data

IE3 cast iron motors, 1000 r/min

IP 55 - IC 411 - Insulation class F, temperature rise class B
IE3 efficiency class according to IEC 60034-30-1; 2014

| Output kW | Motor type | Product code | Speed r/min | Efficiency IEC 60034-30-1; 2014 | | | Power factor Cos ϕ | Current | | | | | Torque T_N Nm | Moment of inertia $J = 1/4$ GD ² kgm ² | Weight kg | Sound pressure Level L _{PA} dB |
|----------------------|---------------|----------------|----------------|------------------------------------|--------------------|--------------------|-------------------------------|---------------------|--------------------------------|----------------------|--------------------------------|--------------------------------|-----------------------|-----------------------------------------------------------------------|--------------|--------------------------------------------------|
| | | | | Full load 100% | 3/4 load 75% | 1/2 load 50% | | I _N A | I _s /I _N | T _N Nm | T _f /T _N | T _b /T _N | | | | |
| 1000 r/min = 6 poles | | | | 400 V 50 Hz | | | | CENELEC-design | | | | | | | | |
| 0.18 | M3BP 71ME 6 | 3GBP073350-••L | 887 | 63,9 | 64,2 | 59,7 | 0,74 | 0,57 | 3,2 | 1,9 | 1,9 | 2,2 | 0,00091 | 10 | 45 | |
| 0.25 | M3BP 80MB 6 | 3GBP083320-••L | 942 | 68,6 | 67 | 61,7 | 0,61 | 0,82 | 4,8 | 2,5 | 2,7 | 2,9 | 0,0019 | 14 | 47 | |
| 0.37 | M3BP 80MC 6 | 3GBP083330-••L | 936 | 73,5 | 73,9 | 71,1 | 0,67 | 1,06 | 5,1 | 3,8 | 2,6 | 2,9 | 0,0028 | 16 | 50 | |
| 0.55 | M3BP 80ME 6 | 3GBP083350-••L | 933 | 77,2 | 77,9 | 75,9 | 0,68 | 1,52 | 5 | 5,6 | 2,7 | 2,9 | 0,0035 | 18 | 47 | |
| 0.75 | M3BP 90SLD 6 | 3GBP093040-••L | 940 | 78,9 | 80,3 | 79,2 | 0,75 | 1,8 | 4,4 | 7,6 | 2,1 | 2,8 | 0,00560 | 29 | 44 | |
| 1.1 | M3BP 90LF 6 | 3GBP093560-••L | 944 | 81,0 | 81,7 | 80,1 | 0,75 | 2,6 | 4,7 | 11,1 | 2,1 | 2,8 | 0,00680 | 33 | 44 | |
| 1.5 | M3BP 100MLB 6 | 3GBP103420-••L | 960 | 82,5 | 82,5 | 80,1 | 0,68 | 3,8 | 5,4 | 14,9 | 2,7 | 3,4 | 0,0120 | 41 | 49 | |
| 2.2 | M3BP 112MJ 6 | 3GBP113390-••L | 962 | 84,3 | 85,5 | 84,7 | 0,68 | 5,3 | 4,2 | 21,8 | 1,4 | 2,3 | 0,0196 | 53 | 66 | |
| 3 | M3BP 132SMB 6 | 3GBP133220-••L | 973 | 85,6 | 85,1 | 82,9 | 0,62 | 8,0 | 6,6 | 29,2 | 2,7 | 3,8 | 0,0355 | 75 | 57 | |
| 4 | M3BP 132SMF 6 | 3GBP133260-••L | 971 | 86,8 | 86,5 | 84,7 | 0,62 | 10,7 | 6,6 | 39,0 | 2,7 | 3,8 | 0,0416 | 82 | 57 | |
| 5.5 | M3BP 132SMJ 6 | 3GBP133290-••L | 966 | 88,0 | 89,1 | 88,9 | 0,73 | 12,3 | 4,2 | 54,0 | 1,7 | 2,7 | 0,0408 | 81 | 57 | |
| 7.5 | M3BP 160MLA 6 | 3GBP163410-••L | 975 | 89,1 | 90,0 | 90,0 | 0,77 | 15,7 | 5,7 | 73,2 | 1,4 | 3,0 | 0,0890 | 146 | 59 | |
| 11 | M3BP 160MLB 6 | 3GBP163420-••L | 975 | 90,3 | 91,1 | 91,1 | 0,78 | 22,5 | 6,4 | 108 | 1,6 | 3,1 | 0,138 | 180 | 64 | |
| 15 | M3BP 180MLA 6 | 3GBP183410-••L | 979 | 91,2 | 91,9 | 91,6 | 0,79 | 30,1 | 5,2 | 147 | 1,5 | 2,7 | 0,212 | 212 | 63 | |
| 18.5 | M3BP 200MLA 6 | 3GBP203410-••L | 989 | 91,7 | 91,9 | 91,2 | 0,82 | 35,2 | 6,5 | 179 | 2,2 | 3,2 | 0,496 | 272 | 59 | |
| 22 | M3BP 200MLB 6 | 3GBP203420-••L | 989 | 92,2 | 92,4 | 91,4 | 0,81 | 42,4 | 7,3 | 212 | 2,6 | 3,5 | 0,585 | 297 | 59 | |
| 30 | M3BP 225SMA 6 | 3GBP223210-••L | 988 | 92,9 | 93,0 | 92,2 | 0,77 | 60,4 | 7,7 | 291 | 2,9 | 3,6 | 0,724 | 349 | 63 | |
| 37 | M3BP 250SMA 6 | 3GBP253210-••L | 990 | 93,3 | 93,7 | 93,5 | 0,80 | 71,1 | 6,5 | 357 | 2,4 | 3,1 | 1,30 | 431 | 58 | |
| 45 | M3BP 280SMB 6 | 3GBP283220-••L | 991 | 93,7 | 94,0 | 93,5 | 0,84 | 82,0 | 7,4 | 433 | 2,7 | 3,0 | 1,870 | 645 | 72 | |
| 55 | M3BP 280SMC 6 | 3GBP283230-••L | 992 | 94,1 | 94,3 | 93,8 | 0,86 | 99,0 | 7,5 | 528 | 2,8 | 3,0 | 2,570 | 725 | 71 | |
| 75 | M3BP 315SMB 6 | 3GBP313220-••L | 994 | 94,6 | 94,9 | 94,6 | 0,84 | 136 | 6,8 | 720 | 1,8 | 2,6 | 4,10 | 930 | 75 | |
| 90 | M3BP 315SMC 6 | 3GBP313230-••L | 994 | 94,9 | 95,1 | 94,7 | 0,84 | 164 | 7,2 | 864 | 2,0 | 3,0 | 4,60 | 1000 | 76 | |
| 110 | M3BP 315SMD 6 | 3GBP313240-••L | 994 | 95,1 | 95,3 | 95,0 | 0,83 | 200 | 7,3 | 1056 | 2,2 | 3,1 | 4,90 | 1040 | 75 | |
| 132 | M3BP 315MLB 6 | 3GBP313420-••L | 995 | 95,4 | 95,5 | 95,1 | 0,82 | 242 | 7,3 | 1266 | 2,3 | 3,2 | 6,30 | 1200 | 72 | |
| 160 | M3BP 355SMA 6 | 3GBP353210-••L | 993 | 95,6 | 95,8 | 95,6 | 0,82 | 292 | 6,7 | 1538 | 2,5 | 2,6 | 7,90 | 1520 | 75 | |
| 200 | M3BP 355SMB 6 | 3GBP353220-••L | 993 | 95,8 | 96,2 | 96,1 | 0,82 | 365 | 6,7 | 1923 | 2,6 | 2,5 | 9,70 | 1680 | 75 | |
| 250 | M3BP 355SMC 6 | 3GBP353230-••L | 993 | 95,8 | 96,1 | 95,8 | 0,81 | 465 | 7,7 | 2404 | 3,0 | 3,1 | 11,30 | 1820 | 75 | |
| 315 | M3BP 355MLB 6 | 3GBP353420-••L | 993 | 95,8 | 96,1 | 96,0 | 0,83 | 571 | 6,8 | 3029 | 2,6 | 3,2 | 13,50 | 2180 | 76 | |
| 355 | M3BP 355LKA 6 | 3GBP353810-••L | 993 | 95,8 | 96,0 | 95,9 | 0,81 | 653 | 7,5 | 3413 | 2,9 | 3,2 | 15,50 | 2500 | 76 | |

| Output kW | Motor type | Product code | Speed r/min | Efficiency IEC 60034-30-1; 2014 | | | Power factor Cos ϕ | Current | | | | | Torque T_N Nm | Moment of inertia $J = 1/4$ GD ² kgm ² | Weight kg | Sound pressure Level L _{PA} dB |
|----------------------|---------------|----------------|----------------|------------------------------------|--------------------|--------------------|-------------------------------|---------------------|--------------------------------|----------------------|--------------------------------|--------------------------------|-----------------------|-----------------------------------------------------------------------|--------------|--------------------------------------------------|
| | | | | Full load 100% | 3/4 load 75% | 1/2 load 50% | | I _N A | I _s /I _N | T _N Nm | T _f /T _N | T _b /T _N | | | | |
| 1000 r/min = 6 poles | | | | 400 V 50 Hz | | | | High-output design | | | | | | | | |
| 18.5 | M3BP 180MLB 6 | 3GBP183420-••L | 980 | 91,7 | 92,5 | 92,0 | 0,75 | 38,8 | 6,4 | 180 | 2,1 | 3,1 | 0,220 | 219 | 65 | |
| 37 | M3BP 225SMB 6 | 3GBP223220-••L | 985 | 93,3 | 93,7 | 93,4 | 0,80 | 71,5 | 7,0 | 359 | 2,7 | 3,0 | 0,813 | 382 | 68 | |
| 45 | M3BP 250SMB 6 | 3GBP253220-••L | 991 | 93,7 | 94,1 | 93,6 | 0,81 | 85,5 | 7,6 | 434 | 2,9 | 3,3 | 1,50 | 465 | 68 | |
| 55 | M3BP 250SMC 6 | 3GBP253230-••L | 989 | 94,1 | 94,7 | 94,5 | 0,80 | 105 | 7,1 | 531 | 3,0 | 3,1 | 1,490 | 466 | 68 | |
| 75 | M3BP 280SMD 6 | 3GBP283240-••L | 991 | 94,6 | 94,9 | 94,5 | 0,85 | 135 | 7,6 | 723 | 2,8 | 3,0 | 3,00 | 740 | 73 | |
| 160 | M3BP 315LKA 6 | 3GBP313810-••L | 994 | 95,6 | 95,8 | 95,4 | 0,81 | 298 | 7,5 | 1535 | 2,2 | 3,1 | 7,30 | 1410 | 76 | |
| 180 | M3BP 315LKB 6 | 3GBP313820-••L | 994 | 95,8 | 95,9 | 95,4 | 0,82 | 331 | 7,6 | 1729 | 2,3 | 3,1 | 8,30 | 1520 | 76 | |
| 200 | M3BP 315LKC 6 | 3GBP313830-••L | 993 | 95,8 | 96,1 | 95,8 | 0,82 | 367 | 7,0 | 1923 | 2,2 | 2,8 | 9,20 | 1600 | 76 | |

Technical data

IE3 Cast iron motors, 1000 r/min

IP 55 - IC 411 - Insulation class F, temperature rise class B
IE3 efficiency class according to IEC 60034-30-1; 2014

| Output kW | Motor type | Product code | Speed r/min | Efficiency IEC 60034-30-1; 2014 | | | Power factor Cosφ | Current Torque | | | | | Moment of inertia J = 1/4 GD ² kgm ² | Weight kg | Sound pressure Level L _{PA} dB |
|-----------------------------|---------------|----------------|-------------|---------------------------------|--------------|--------------|-------------------|-----------------------|--------------------------------|-------------------|--------------------------------|--------------------------------|------------------------------------------------------------|-----------|-----------------------------------------|
| | | | | Full load 100% | 3/4 load 75% | 1/2 load 50% | | I _N A | I _s /I _N | T _N Nm | T _f /T _N | T _b /T _N | | | |
| 1000 r/min = 6 poles | | | | 400 V 50 Hz | | | | CENELEC-design | | | | | | | |
| 0.25 | M3BP 80MA 6 | 3GBP083310-••K | 937 | 73,3 | 72,2 | 67,6 | 0,64 | 0,76 | 2,6 | 2,52 | 1,4 | 2 | 0,0019 | 14 | 47 |
| 0.37 | M3BP 80MD 6 | 3GBP083340-••K | 930 | 77,9 | 78,6 | 76,7 | 0,72 | 0,95 | 3,3 | 3,75 | 1,5 | 2 | 0,0028 | 16 | 47 |
| 0.55 | M3BP 80MLG 6 | 3GBP083470-••K | 937 | 80,4 | 81 | 79,5 | 0,63 | 1,56 | 4,4 | 5,6 | 1,9 | 2,2 | 0,0044 | 21 | 47 |
| 0.75 | M3BP 90LG 6 | 3GBP093570-••K | 938 | 81,5 | 82,8 | 82,2 | 0,74 | 1,8 | 4,8 | 7,7 | 2,4 | 2,7 | 0,00720 | 34 | 44 |
| 1.1 | M3BP 100LKG 6 | 3GBP103870-••K | 969 | 84,4 | 84,5 | 82,8 | 0,68 | 2,6 | 4,1 | 10,9 | 1,6 | 2,2 | 0,00250 | 47 | 49 |
| 1.5 | M3BP 112MH 6 | 3GBP113380-••K | 972 | 85,8 | 85,6 | 83,6 | 0,64 | 3,8 | 4,5 | 14,7 | 1,3 | 2,5 | 0,0196 | 53 | 66 |
| 2.2 | M3BP 132SMC 6 | 3GBP133230-••K | 978 | 87,3 | 87,5 | 86,1 | 0,69 | 5,1 | 5,4 | 21,5 | 2,0 | 2,6 | 0,0416 | 81 | 57 |
| 3 | M3BP 132SMD 6 | 3GBP133240-••K | 977 | 88,5 | 88,8 | 87,5 | 0,69 | 6,9 | 5,9 | 29,0 | 1,4 | 2,8 | 0,0416 | 82 | 57 |
| 4 | M3BP 132SMG 6 | 3GBP133270-••K | 974 | 89,4 | 89,9 | 89,3 | 0,69 | 9,3 | 5,6 | 38,7 | 2,2 | 2,8 | 0,0416 | 82 | 57 |
| 5.5 | M3BP 132SMH 6 | 3GBP133280-••K | 966 | 89,6 | 90,4 | 90,2 | 0,73 | 12,1 | 5,0 | 54,1 | 1,8 | 2,7 | 0,0654 | 79 | 57 |
| 7.5 | M3BP 160MLA 6 | 3GBP163410-••K | 980 | 90,8 | 91,5 | 91,0 | 0,78 | 15,2 | 7,9 | 73,0 | 1,7 | 3,3 | 0,114 | 164 | 59 |
| 11 | M3BP 160MLB 6 | 3GBP163420-••K | 979 | 91,2 | 91,8 | 91,1 | 0,74 | 23,5 | 8,5 | 107,0 | 2,2 | 3,9 | 0,131 | 177 | 59 |
| 15 | M3BP 180MLA 6 | 3GBP183410-••K | 981 | 92,2 | 92,4 | 91,5 | 0,77 | 30,4 | 7,7 | 146,0 | 2,2 | 3,5 | 0,225 | 220 | 59 |
| 18.5 | M3BP 200MLA 6 | 3GBP203410-••K | 990 | 92,8 | 93,2 | 92,6 | 0,77 | 37,3 | 7,5 | 178,0 | 2,6 | 3,2 | 0,448 | 272 | 63 |
| 22 | M3BP 200MLB 6 | 3GBP203420-••K | 990 | 93,3 | 93,7 | 93,1 | 0,79 | 43,0 | 7,8 | 212,0 | 2,6 | 3,2 | 0,531 | 293 | 63 |
| 30 | M3BP 225SMA 6 | 3GBP223210-••K | 989 | 94,1 | 94,6 | 94,4 | 0,81 | 56,8 | 7,9 | 289,0 | 2,8 | 3,1 | 0,813 | 370 | 63 |
| 37 | M3BP 250SMA 6 | 3GBP253210-••K | 991 | 94,4 | 94,9 | 94,7 | 0,83 | 68,0 | 7,7 | 356,0 | 2,7 | 2,9 | 1,490 | 457 | 63 |
| 45 | M3BP 280SMB 6 | 3GBP283220-••K | 992 | 94,7 | 95,1 | 94,6 | 0,85 | 80,9 | 6,9 | 434,0 | 2,4 | 2,6 | 2,20 | 680 | 65 |
| 55 | M3BP 280SMC 6 | 3GBP283230-••K | 990 | 95,0 | 95,4 | 95,0 | 0,85 | 99,4 | 6,8 | 506,0 | 2,4 | 2,6 | 2,850 | 725 | 65 |
| 75 | M3BP 315SMC 6 | 3GBP313230-••K | 994 | 95,3 | 95,6 | 95,2 | 0,83 | 138 | 7,0 | 721,0 | 2,2 | 2,8 | 4,90 | 1000 | 67 |
| 90 | M3BP 315SMD 6 | 3GBP313240-••K | 994 | 95,5 | 95,8 | 95,4 | 0,81 | 170 | 7,2 | 864 | 2,4 | 2,9 | 4,90 | 1040 | 67 |
| 110 | M3BP 315MLB 6 | 3GBP313420-••K | 994 | 95,7 | 95,9 | 95,7 | 0,83 | 202 | 6,9 | 1058 | 2,3 | 2,7 | 6,30 | 1200 | 68 |
| 132 | M3BP 315LKA 6 | 3GBP313810-••K | 993 | 95,9 | 96,1 | 95,9 | 0,82 | 243 | 6,9 | 1269 | 2,4 | 2,7 | 7,30 | 1410 | 68 |
| 160 | M3BP 355SMB 6 | 3GBP353220-••K | 995 | 96,1 | 96,1 | 95,6 | 0,82 | 294 | 7,0 | 1536 | 2,1 | 2,7 | 9,70 | 1680 | 73 |
| 200 | M3BP 355SMC 6 | 3GBP353230-••K | 995 | 96,2 | 96,4 | 96,1 | 0,82 | 367 | 7,3 | 1920 | 2,3 | 2,8 | 11,30 | 1820 | 73 |
| 250 | M3BP 355MLB 6 | 3GBP353420-••K | 995 | 96,4 | 96,6 | 96,5 | 0,83 | 456 | 7,1 | 2399 | 2,3 | 2,7 | 13,50 | 2180 | 73 |
| 315 | M3BP 355LKA 6 | 3GBP353810-••K | 994 | 96,5 | 96,7 | 96,4 | 0,83 | 576 | 6,9 | 3026 | 2,3 | 2,6 | 15,50 | 2500 | 76 |
| 355 | M3BP 355LKB 6 | 3GBP353820-••K | 995 | 96,5 | 96,6 | 96,1 | 0,81 | 668 | 7,7 | 3407 | 2,7 | 2,9 | 16,50 | 2600 | 76 |

| Output kW | Motor type | Product code | Speed r/min | Efficiency IEC 60034-30-1; 2014 | | | Power factor Cosφ | Current Torque | | | | | Moment of inertia J = 1/4 GD ² kgm ² | Weight kg | Sound pressure Level L _{PA} dB |
|-----------------------------|---------------|----------------|-------------|---------------------------------|--------------|--------------|-------------------|---------------------------|--------------------------------|-------------------|--------------------------------|--------------------------------|------------------------------------------------------------|-----------|-----------------------------------------|
| | | | | Full load 100% | 3/4 load 75% | 1/2 load 50% | | I _N A | I _s /I _N | T _N Nm | T _f /T _N | T _b /T _N | | | |
| 1000 r/min = 6 poles | | | | 400 V 50 Hz | | | | High-output design | | | | | | | |
| 160 | M3BP 315LKC 6 | 3GBP313830-••K | 994 | 96,1 | 96,3 | 96,2 | 0,82 | 297 | 7,4 | 1537 | 2,7 | 2,9 | 9,20 | 1600 | 68 |

Technical data

IE4 cast iron motors, 3000, 1500, 1000 r/min

IP 55 - IC 411 - Insulation class F, temperature rise class B
IE4 efficiency class according to IEC 60034-30-1; 2014

| Output kW | Motor type | Product code | Speed r/min | Efficiency IEC 60034-30-1; 2014 | | | Power factor Cos ϕ | Current Torque | | | | | Moment of inertia J = 1/4 GD ² kgm ² | Weight kg | Sound pressure Level L _{PA} dB |
|-----------------------------|---------------|----------------|-------------|---------------------------------|--------------|--------------|-------------------------|-----------------------|--------------------------------|-------------------|--------------------------------|--------------------------------|------------------------------------------------------------|-----------|-----------------------------------------|
| | | | | Full load 100% | 3/4 load 75% | 1/2 load 50% | | I _N A | I _S /I _N | T _N Nm | T _I /T _N | T _B /T _N | | | |
| 3000 r/min = 2 poles | | | | 400 V 50 Hz | | | | CENELEC-design | | | | | | | |
| 75 | M3BP 280SMB 2 | 3GBP281220-••M | 2980 | 96,3 | 96,3 | 95,8 | 0,87 | 129 | 7,3 | 240 | 2,1 | 2,9 | 0,90 | 665 | 77 |
| 90 | M3BP 280SMC 2 | 3GBP281230-••M | 2981 | 96,5 | 96,4 | 95,9 | 0,88 | 153 | 8,0 | 288 | 2,5 | 3,1 | 1,150 | 725 | 77 |
| 110 | M3BP 315SMB 2 | 3GBP311220-••M | 2982 | 96,5 | 96,5 | 95,9 | 0,88 | 189 | 6,7 | 352 | 1,9 | 2,6 | 1,40 | 940 | 77 |
| 132 | M3BP 315SMC 2 | 3GBP311230-••M | 2986 | 96,9 | 97,0 | 96,7 | 0,88 | 226 | 7,9 | 422 | 2,4 | 3,0 | 1,70 | 1025 | 77 |
| 160 | M3BP 315MLA 2 | 3GBP311410-••M | 2983 | 97,1 | 97,3 | 97,1 | 0,90 | 268 | 7,3 | 512 | 2,2 | 2,7 | 2,10 | 1190 | 77 |
| 200 | M3BP 315MLB 2 | 3GBP311420-••M | 2983 | 97,1 | 97,4 | 97,3 | 0,90 | 333 | 6,8 | 640 | 1,9 | 2,6 | 2,20 | 1220 | 77 |
| 200 ¹⁾ | M3BP 355SMA 2 | 3GBP351210-••M | 2985 | 97,0 | 96,8 | 96,1 | 0,90 | 336 | 7,6 | 640 | 2 | 3,1 | 3,00 | 1600 | 83 |
| 250 | M3BP 315LKB 2 | 3GBP311820-••M | 2982 | 96,9 | 97,2 | 97,2 | 0,91 | 413 | 7,9 | 800 | 2,5 | 2,7 | 2,90 | 1540 | 77 |
| 250 ¹⁾ | M3BP 355SMB 2 | 3GBP351220-••M | 2983 | 97,3 | 97,4 | 97,1 | 0,90 | 415 | 7,6 | 800 | 2,2 | 3,0 | 3,40 | 1680 | 83 |
| 315 ¹⁾ | M3BP 355SMC 2 | 3GBP351230-••M | 2984 | 96,8 | 96,8 | 96,3 | 0,89 | 533 | 7,8 | 1008 | 2,3 | 2,8 | 3,60 | 1750 | 83 |
| 355 ¹⁾ | M3BP 355MLA 2 | 3GBP351410-••M | 2981 | 96,9 | 97,1 | 96,8 | 0,90 | 595 | 7,5 | 1137 | 2,3 | 2,6 | 4,10 | 2000 | 83 |

| Output kW | Motor type | Product code | Speed r/min | Efficiency IEC 60034-30-1; 2014 | | | Power factor Cos ϕ | Current Torque | | | | | Moment of inertia J = 1/4 GD ² kgm ² | Weight kg | Sound pressure Level L _{PA} dB |
|-----------------------------|---------------|----------------|-------------|---------------------------------|--------------|--------------|-------------------------|-----------------------|--------------------------------|-------------------|--------------------------------|--------------------------------|------------------------------------------------------------|-----------|-----------------------------------------|
| | | | | Full load 100% | 3/4 load 75% | 1/2 load 50% | | I _N A | I _S /I _N | T _N Nm | T _I /T _N | T _B /T _N | | | |
| 1500 r/min = 4 poles | | | | 400 V 50 Hz | | | | CENELEC-design | | | | | | | |
| 75 | M3BP 280SMC 4 | 3GBP282230-••M | 1487 | 96,2 | 96,6 | 96,3 | 0,86 | 130 | 7,8 | 481 | 2,8 | 2,9 | 1,85 | 725 | 72 |
| 90 | M3BP 280MLA 4 | 3GBP282410-••M | 1489 | 96,4 | 96,8 | 96,7 | 0,85 | 160 | 8,8 | 577 | 3,4 | 3,2 | 2,30 | 840 | 72 |
| 110 | M3BP 315SMC 4 | 3GBP312230-••M | 1491 | 96,8 | 97,0 | 96,7 | 0,85 | 194 | 7,8 | 704 | 2,4 | 3,1 | 2,90 | 1000 | 68 |
| 132 | M3BP 315SMD 4 | 3GBP312240-••M | 1490 | 96,9 | 97,1 | 96,8 | 0,85 | 234 | 7,9 | 846 | 2,6 | 3,2 | 3,20 | 1065 | 68 |
| 160 | M3BP 315MLB 4 | 3GBP312420-••M | 1490 | 96,7 | 96,9 | 96,6 | 0,87 | 278 | 7,9 | 1026 | 2,7 | 3,0 | 3,90 | 1220 | 68 |
| 200 | M3BP 315LKB 4 | 3GBP312820-••M | 1490 | 96,9 | 97,1 | 97,0 | 0,87 | 346 | 7,6 | 1282 | 2,5 | 2,9 | 5,0 | 1520 | 74 |
| 200 | M3BP 355SMA 4 | 3GBP352210-••M | 1491 | 97,0 | 97,1 | 96,8 | 0,87 | 345 | 7,3 | 1282 | 2,1 | 2,7 | 5,90 | 1610 | 74 |
| 250 | M3BP 315LKC 4 | 3GBP312830-••M | 1490 | 96,9 | 97,1 | 97,0 | 0,87 | 432 | 7,8 | 1601 | 2,3 | 3,0 | 5,50 | 1600 | 74 |
| 250 | M3BP 355SMB 4 | 3GBP352220-••M | 1491 | 97,1 | 97,2 | 97,0 | 0,87 | 433 | 7,8 | 1601 | 2,5 | 2,9 | 6,90 | 1780 | 74 |
| 315 | M3BP 355SMC 4 | 3GBP352230-••M | 1490 | 97,2 | 97,3 | 97,1 | 0,86 | 554 | 7,4 | 2017 | 2,8 | 2,9 | 7,20 | 1820 | 74 |
| 355 | M3BP 355MLA 4 | 3GBP352410-••M | 1491 | 96,9 | 97,1 | 96,8 | 0,87 | 616 | 7,9 | 2274 | 2,7 | 2,9 | 8,40 | 2140 | 78 |

| Output kW | Motor type | Product code | Speed r/min | Efficiency IEC 60034-30-1; 2014 | | | Power factor Cos ϕ | Current Torque | | | | | Moment of inertia J = 1/4 GD ² kgm ² | Weight kg | Sound pressure Level L _{PA} dB |
|-----------------------------|---------------|----------------|-------------|---------------------------------|--------------|--------------|-------------------------|-----------------------|--------------------------------|-------------------|--------------------------------|--------------------------------|------------------------------------------------------------|-----------|-----------------------------------------|
| | | | | Full load 100% | 3/4 load 75% | 1/2 load 50% | | I _N A | I _S /I _N | T _N Nm | T _I /T _N | T _B /T _N | | | |
| 1000 r/min = 6 poles | | | | 400 V 50 Hz | | | | CENELEC-design | | | | | | | |
| 45 | M3BP 280SMB 6 | 3GBP283220-••M | 992 | 95,4 | 95,7 | 95,3 | 0,85 | 80,9 | 6,9 | 434 | 2,4 | 2,6 | 2,20 | 680 | 65 |
| 55 | M3BP 280SMC 6 | 3GBP283230-••M | 990 | 95,4 | 95,7 | 95,4 | 0,85 | 99,4 | 6,8 | 506 | 2,4 | 2,6 | 2,85 | 725 | 65 |
| 75 | M3BP 315SMC 6 | 3GBP313230-••M | 994 | 96,3 | 96,5 | 96,2 | 0,83 | 138 | 7,0 | 721 | 2,2 | 2,8 | 4,90 | 1000 | 67 |
| 90 | M3BP 315SMD 6 | 3GBP313240-••M | 994 | 96,0 | 96,2 | 95,9 | 0,81 | 170 | 7,2 | 864 | 2,4 | 2,9 | 4,90 | 1040 | 67 |
| 110 | M3BP 315MLB 6 | 3GBP313420-••M | 994 | 96,4 | 96,6 | 96,4 | 0,83 | 202 | 6,9 | 1057 | 2,3 | 2,7 | 6,30 | 1200 | 68 |
| 132 | M3BP 315LKA 6 | 3GBP313810-••M | 993 | 96,4 | 96,6 | 96,4 | 0,82 | 243 | 6,9 | 1269 | 2,4 | 2,7 | 7,30 | 1410 | 68 |
| 160 | M3BP 315LKC 6 | 3GBP313830-••M | 994 | 96,7 | 96,9 | 96,8 | 0,82 | 297 | 7,4 | 1537 | 2,7 | 2,9 | 9,20 | 1600 | 68 |
| 160 | M3BP 355SMB 6 | 3GBP353220-••M | 995 | 96,5 | 96,5 | 96,1 | 0,82 | 294 | 7,0 | 1536 | 2,1 | 2,7 | 9,70 | 1680 | 73 |
| 200 | M3BP 355SMC 6 | 3GBP353230-••M | 995 | 96,5 | 96,7 | 96,4 | 0,82 | 367 | 7,3 | 1920 | 2,3 | 2,8 | 11,30 | 1820 | 73 |
| 250 | M3BP 355MLB 6 | 3GBP353420-••M | 995 | 96,6 | 96,8 | 96,7 | 0,83 | 456 | 7,1 | 2399 | 2,3 | 2,7 | 13,50 | 2180 | 73 |
| 315 | M3BP 355LKA 6 | 3GBP353810-••M | 994 | 96,6 | 96,7 | 96,5 | 0,83 | 576 | 6,9 | 3026 | 2,3 | 2,6 | 15,50 | 2500 | 76 |
| 355 | M3BP 355LKB 6 | 3GBP353820-••M | 995 | 96,7 | 96,7 | 96,3 | 0,81 | 668 | 7,7 | 3407 | 2,7 | 2,9 | 16,50 | 2600 | 76 |

¹⁾ 3dB(A) sound pressure level reduction with unidirectional fan construction. Direction of rotation must be stated when ordering, see variant codes 044 and 045

Variant codes

Cast iron motors

Variant codes specify additional options and features to the standard motor. The desired features are listed as three-digit variant codes in the motor order. Note also that there are variants that cannot be used together.

Most of the variant codes apply to IE2, IE3, and IE4 motors. However, confirm the availability of variants for IE3 and IE4 motors with your ABB sales office before making an order.

| Code/Variants | Frame size | | | | | | | | | | | | | | | |
|---------------------------------|--------------------------------------------------------------------------------------------|----|----|-----|-----|-----|-----|-----|-----|-----|-----|-----|-----|-----|-----|-----|
| | 71 | 80 | 90 | 100 | 112 | 132 | 160 | 180 | 200 | 225 | 250 | 280 | 315 | 355 | 400 | 450 |
| Administration | | | | | | | | | | | | | | | | |
| 530 | Two-year extension on standard warranty | | | | | | | | | | | | | | | |
| 531 | Sea freight packing | | | | | | | | | | | | | | | |
| 532 | Packing of motor in vertical mounting position | | | | | | | | | | | | | | | |
| 533 | Wooden sea freight packing | | | | | | | | | | | | | | | |
| 590 | Mounting of customer supplied part other than coupling. | | | | | | | | | | | | | | | |
| Balancing | | | | | | | | | | | | | | | | |
| 417 | Vibration acc. to Grade B (IEC 60034-14). | | | | | | | | | | | | | | | |
| 423 | Balanced without key. | | | | | | | | | | | | | | | |
| 424 | Full-key balancing | | | | | | | | | | | | | | | |
| Bearings and Lubrication | | | | | | | | | | | | | | | | |
| 036 | Transport lock for bearings. | | | | | | | | | | | | | | | |
| 037 | Roller bearing at D-end. | | | | | | | | | | | | | | | |
| 039 | Cold-resistant grease | | | | | | | | | | | | | | | |
| 040 | Heat-resistant grease | | | | | | | | | | | | | | | |
| 041 | Bearings regreasable via grease nipples. | | | | | | | | | | | | | | | |
| 043 | SPM compatible nipples for vibration measurement | | | | | | | | | | | | | | | |
| 057 | 2RS bearings at both ends. | | | | | | | | | | | | | | | |
| 058 | Angular contact bearing at D-end, shaft force away from bearing. | | | | | | | | | | | | | | | |
| 059 | Angular contact bearing at N-end, shaft force towards bearing. | | | | | | | | | | | | | | | |
| 060 | Angular contact bearing at D-end, shaft force towards bearing. | | | | | | | | | | | | | | | |
| 061 | Angular contact bearing at N-end, shaft force away from bearing. | | | | | | | | | | | | | | | |
| 107 | Pt100 2-wire in bearings. | | | | | | | | | | | | | | | |
| 128 | Double PT100, 2-wire in bearings | | | | | | | | | | | | | | | |
| 129 | Double PT100, 3-wire in bearings | | | | | | | | | | | | | | | |
| 130 | Pt100 3-wire in bearings. | | | | | | | | | | | | | | | |
| 188 | 63-series bearing in D-end | | | | | | | | | | | | | | | |
| 194 | 2Z bearings greased for life at both ends. | | | | | | | | | | | | | | | |
| 420 | Bearing mounted PTC thermistors. | | | | | | | | | | | | | | | |
| 433 | Outlet grease collector | | | | | | | | | | | | | | | |
| 506 | Nipples for vibration measurement : SKF Marlin Quick Connect stud CMSS-2600-3 | | | | | | | | | | | | | | | |
| 593 | Bearings grease suitable for food and beverage industry. | | | | | | | | | | | | | | | |
| 654 | Provision for vibration sensors (M8x1) | | | | | | | | | | | | | | | |
| 795 | Lubrication information plate | | | | | | | | | | | | | | | |
| 796 | Grease nipples JIS B 1575 PT 1/8 Type A | | | | | | | | | | | | | | | |
| 797 | Stainless steel SPM nipples | | | | | | | | | | | | | | | |
| 798 | Stainless steel grease nipples | | | | | | | | | | | | | | | |
| 799 | Grease nipples flat type DIN 3404, thread M10x1 | | | | | | | | | | | | | | | |
| 800 | Grease nipples JIS B 1575 PT 1/8" pin type | | | | | | | | | | | | | | | |
| Brakes | | | | | | | | | | | | | | | | |
| 517 | KFB holding brake | | | | | | | | | | | | | | | |
| 518 | SFB-SH holding brake | | | | | | | | | | | | | | | |
| Branch standard designs | | | | | | | | | | | | | | | | |
| 142 | Manilla connection. | | | | | | | | | | | | | | | |
| 172 | Smoke venting specification, 300 °C, 1 hour, DOL use, class F300 according to EN 12101-3 | | | | | | | | | | | | | | | |
| 173 | Smoke venting specification, 200 °C, 2 hours, DOL use, class F200 according to EN 12101-3 | | | | | | | | | | | | | | | |
| 174 | Smoke venting specification, 400 °C, 2 hours, DOL use, class F400 according to EN 12101-3 | | | | | | | | | | | | | | | |
| 177 | Design for high ambient applications | | | | | | | | | | | | | | | |
| 178 | Stainless steel / acid proof bolts. | | | | | | | | | | | | | | | |
| 204 | Jacking bolts for foot mounted motors. | | | | | | | | | | | | | | | |
| 209 | Non-standard voltage or frequency, (special winding). | | | | | | | | | | | | | | | |
| 386 | Smoke venting specification, 200 °C, 2 hours, VSD use, Class F200 according to EN 12101-3. | | | | | | | | | | | | | | | |

○ = Included as standard | ● = Available as option | - = Not applicable

| Code/Variants | Frame size | | | | | | | | | | | | | | | |
|--------------------------|---------------------------------------------------------------------------------------------------------------------------|----|----|-----|-----|-----|-----|-----|-----|-----|-----|-----|-----|-----|-----|-----|
| | 71 | 80 | 90 | 100 | 112 | 132 | 160 | 180 | 200 | 225 | 250 | 280 | 315 | 355 | 400 | 450 |
| 387 | Smoke venting specification, 300 °C, 1 hour, VSD use, Class F300 according to EN 12101-3 | | | | | | | | | | | | | | | |
| 389 | Smoke Venting specification, 400 °C, 2 hours, VSD use, Class F400 according to EN 12101-3 | | | | | | | | | | | | | | | |
| 392 | Smoke Venting specification, 250 °C, 2 hours, DOL use, Class T250 | | | | | | | | | | | | | | | |
| 393 | Smoke venting specification, 250 °C, 2 hours, VSD use, Class T250 | | | | | | | | | | | | | | | |
| 396 | Motor designed for ambient temperature -20 °C to -40 °C, with space heaters (code 450/451 must be added) | | | | | | | | | | | | | | | |
| 397 | Motor designed for ambient temperature -40 °C to -55 °C, with space heaters (code 450/451 must be added) | | | | | | | | | | | | | | | |
| 398 | Motor designed for ambient temperature -20 °C to -40 °C | | | | | | | | | | | | | | | |
| 399 | Motor designed for ambient temperature -40 °C to -55 °C | | | | | | | | | | | | | | | |
| 425 | Corrosion protected stator and rotor core. | | | | | | | | | | | | | | | |
| 524 | Special run-out tolerances on flange and shaft for close coupled pump applications. | | | | | | | | | | | | | | | |
| Cooling system | | | | | | | | | | | | | | | | |
| 044 | Unidirectional fan for reduced noise level. Rotation clockwise seen from D-end. Available only for 2-pole motors. | | | | | | | | | | | | | | | |
| 045 | Unidirectional fan for reduced noise level. Rotation counter clockwise seen from D-end. Available only for 2-pole motors. | | | | | | | | | | | | | | | |
| 068 | Light alloy metal fan | | | | | | | | | | | | | | | |
| 075 | Cooling method IC418 (without fan). | | | | | | | | | | | | | | | |
| 183 | Separate motor cooling (fan axial, N-end). | | | | | | | | | | | | | | | |
| 206 | Steel fan | | | | | | | | | | | | | | | |
| 422 | Separate motor cooling (on top) with integrated fan motor | | | | | | | | | | | | | | | |
| 514 | Separate motor cooling (fan on top) | | | | | | | | | | | | | | | |
| 791 | Stainless steel fan cover | | | | | | | | | | | | | | | |
| Coupling | | | | | | | | | | | | | | | | |
| 035 | Assembly of customer supplied coupling-half. | | | | | | | | | | | | | | | |
| Documentation | | | | | | | | | | | | | | | | |
| 141 | Binding dimension drawing. | | | | | | | | | | | | | | | |
| Drain holes | | | | | | | | | | | | | | | | |
| 065 | Plugged existing drain holes. | | | | | | | | | | | | | | | |
| 448 | Draining holes with metal plugs. | | | | | | | | | | | | | | | |
| Earthing Bolt | | | | | | | | | | | | | | | | |
| 067 | External earthing bolt. | | | | | | | | | | | | | | | |
| 525 | External earthing bolts on motor feet | | | | | | | | | | | | | | | |
| Heating elements | | | | | | | | | | | | | | | | |
| 450 | Heating element, 100-120 V | | | | | | | | | | | | | | | |
| 451 | Heating element, 200 - 240 V | | | | | | | | | | | | | | | |
| Insulation system | | | | | | | | | | | | | | | | |
| 014 | Winding insulation class H. | | | | | | | | | | | | | | | |
| 405 | Special winding insulation for frequency converter supply. | | | | | | | | | | | | | | | |
| 406 | Winding for supply > 690 <= 1000 volts | | | | | | | | | | | | | | | |
| Marine | | | | | | | | | | | | | | | | |
| 024 | Fulfilling Bureau Veritas (BV) requirements, with certificate. | | | | | | | | | | | | | | | |
| 025 | Fulfilling Det Norske Veritas (DNV) requirements, with certificate. | | | | | | | | | | | | | | | |
| 026 | Fulfilling Lloyds Register of Shipping (LR) requirements, with certificate. | | | | | | | | | | | | | | | |
| 027 | Fulfilling American Bureau of Shipping (ABS) requirements, with certificate. | | | | | | | | | | | | | | | |
| 049 | Fulfilling Germanischer Lloyd (GL) requirements, with certificate. | | | | | | | | | | | | | | | |
| 050 | Fulfilling Registro Italiano Navale (RINA) requirements, with certificate. | | | | | | | | | | | | | | | |
| 051 | Fulfilling Russian Maritime Register of Shipping (RS) requirements, with certificate. | | | | | | | | | | | | | | | |
| 096 | Fulfilling Lloyds Register of Shipping (LR) requirements, without certificate (non-essential duty only) | | | | | | | | | | | | | | | |
| 186 | Fulfilling Det Norske Veritas (DNV) requirements, without certificate (non-essential duty only) | | | | | | | | | | | | | | | |
| 481 | Fulfilling Nippon Kaiji Kyokai (NK) requirements, with certificate. | | | | | | | | | | | | | | | |
| 483 | Fulfilling China Classification Societies (CCS) requirements (Beijing), with certificate. | | | | | | | | | | | | | | | |
| 484 | Fulfilling Korea Register of Shipping (KR) requirements, with certificate. | | | | | | | | | | | | | | | |
| 491 | Fulfilling Nippon Kaiji Kyokai (NK) requirements, without certificate. | | | | | | | | | | | | | | | |
| 492 | Fulfilling Registro Italiano Navale (RINA) requirements, without certificate. | | | | | | | | | | | | | | | |
| 493 | Fulfilling China Classification Societies (CCS) requirements (Beijing), without certificate. | | | | | | | | | | | | | | | |
| 494 | Fulfilling Korea Register of Shipping (KR) requirements, without certificate. | | | | | | | | | | | | | | | |
| 496 | Fulfilling Bureau Veritas (BV) requirements, without certificate(non-essential duty only) | | | | | | | | | | | | | | | |
| 497 | Fulfilling Russian Maritime Register of Shipping (RS) requirements, without certificate. | | | | | | | | | | | | | | | |

○ = Included as standard | ● = Available as option | - = Not applicable

| Code/Variants | Description | Frame size | | | | | | | | | | | | | | | |
|----------------------------------------|---------------------------------------------------------------------------------------------------------------------------------------|------------|----|----|-----|-----|-----|-----|-----|-----|-----|-----|-----|-----|-----|-----|-----|
| | | 71 | 80 | 90 | 100 | 112 | 132 | 160 | 180 | 200 | 225 | 250 | 280 | 315 | 355 | 400 | 450 |
| 675 | Fulfilling American Bureau of Shipping (ABS) requirements, without certificate (non-essential duty only) | • | • | • | • | • | • | • | • | • | • | • | • | • | • | • | • |
| 676 | Fulfilling Germanischer Lloyd (GL) requirements, without certificate (non-essential duty only) | • | • | • | • | • | • | • | • | - | - | • | • | • | • | • | • |
| Mounting arrangements | | | | | | | | | | | | | | | | | |
| 008 | IM 2101 foot/flange mounted, IEC flange, from IM 1001 (B34 from B3). | • | • | • | • | • | • | - | - | - | - | - | - | - | - | - | - |
| 009 | IM 2001 foot/flange mounted, IEC flange, from IM 1001 (B35 from B3). | • | • | • | • | • | • | • | • | • | • | • | • | • | • | • | • |
| 047 | IM 3601 flange mounted, IEC flange, from IM 3001 (B14 from B5). | • | • | • | • | • | • | - | - | - | - | - | - | - | - | - | - |
| 066 | Modified for specified mounting position differing from IM B3 (1001), IM B5 (3001), B14 (3601), IM B35 (2001), IM B34 (2101) | • | • | • | • | • | • | • | • | • | • | • | • | • | • | • | • |
| 305 | Additional lifting lugs. | - | - | - | - | - | - | • | • | • | • | • | • | • | • | • | • |
| Noise reduction | | | | | | | | | | | | | | | | | |
| 055 | Noise reduction cover for foot mounted motor | - | - | - | - | - | - | - | - | - | - | - | • | • | • | • | • |
| Painting | | | | | | | | | | | | | | | | | |
| 105 | Paint thickness report. | • | • | • | • | • | • | • | • | • | • | • | • | • | • | • | • |
| 114 | Special paint color, standard grade | • | • | • | • | • | • | • | • | • | • | • | • | • | • | • | • |
| 115 | Painting system C4M acc. to ISO 12944-2: 1998. | • | • | • | • | • | • | • | • | • | • | • | • | • | • | • | • |
| 168 | Primer paint only. | • | • | • | • | • | • | • | • | • | • | • | • | • | • | • | • |
| 303 | Painted insulation layer on inside of the terminal boxes. | - | - | - | - | - | - | • | • | • | • | • | - | - | - | - | - |
| 710 | Thermally sprayed zinc metallizing with acrylic top coat | • | • | • | • | • | • | • | • | • | • | • | • | • | • | • | • |
| 711 | Painting system C5-M very high, acc. to ISO 12944-2:1998 | • | • | • | • | • | • | • | • | • | • | • | • | • | • | • | • |
| 712 | Painting system C5-M according to Petrobras specification. | • | • | • | • | • | • | • | • | • | • | • | • | • | • | • | • |
| 713 | Painting system according Total Egina specification. | • | • | • | • | • | • | • | • | • | • | • | • | • | • | • | • |
| 754 | Painting system C5M acc. to ISO 12944-2:1998 | • | • | • | • | • | • | • | • | • | • | • | • | • | • | • | • |
| Protection | | | | | | | | | | | | | | | | | |
| 005 | Protective roof, vertical motor, shaft down. | • | • | • | • | • | • | • | • | • | • | • | • | • | • | • | • |
| 072 | Radial seal at D-end. Not possible for 2-pole, 280 and 315 frames | • | • | • | • | • | • | • | • | • | • | • | • | • | - | - | - |
| 073 | Sealed against oil at D-end. | - | - | - | - | - | - | • | • | • | • | • | • | • | • | • | • |
| 158 | Degree of protection IP65. | • | • | • | • | • | • | • | • | • | • | • | • | • | • | • | • |
| 211 | Weather protected, IP xx W | • | • | • | • | • | • | • | • | • | • | • | - | - | - | - | - |
| 250 | Degree of protection IP66 | • | • | • | • | • | • | • | • | • | • | • | • | • | • | • | • |
| 401 | Protective roof, horizontal motor. | - | - | - | - | - | - | • | • | • | • | • | • | • | • | • | • |
| 403 | Degree of protection IP56. | • | • | • | • | • | • | • | • | • | • | • | • | • | • | • | • |
| 404 | Degree of protection IP56, without fan and fan cover. | • | • | • | • | • | • | • | • | • | • | • | - | - | - | - | - |
| 434 | Degree of protection IP56, open deck. | - | - | - | - | - | - | - | - | - | - | - | • | • | • | • | • |
| 520 | Motor protection cover made of glass fiber. Vertical motor, shaft down. | - | - | - | - | - | - | - | - | - | - | - | • | • | • | • | • |
| 783 | Labyrinth sealing at D-end. | - | - | - | - | - | - | • | • | • | • | • | • | • | ○ | ○ | ○ |
| 784 | Gamma-seal at D-end. | • | • | • | • | • | • | ○ | ○ | - | ○ | ○ | - | - | - | - | - |
| Rating & instruction plates | | | | | | | | | | | | | | | | | |
| 002 | Restamping voltage, frequency and output, continuous duty. | • | • | • | • | • | • | • | • | • | • | • | • | • | • | • | • |
| 004 | Additional text on std rating plate (max 12 digits on free text line). | - | - | • | - | • | • | • | • | • | • | • | • | • | • | • | • |
| 095 | Restamping output (maintained voltage, frequency), intermittent duty. | • | • | • | • | • | • | • | • | • | • | • | • | • | • | • | • |
| 098 | Stainless rating plate. | • | • | • | • | • | • | ○ | ○ | ○ | ○ | ○ | ○ | ○ | ○ | ○ | ○ |
| 126 | Tag plate | • | • | • | • | • | • | • | • | • | • | • | • | • | • | • | • |
| 135 | Mounting of additional identification plate, stainless. | • | • | • | • | • | • | • | • | • | • | • | • | • | • | • | • |
| 138 | Mounting of additional identification plate, aluminium. | • | • | • | • | • | • | - | - | - | - | - | - | - | - | - | - |
| 139 | Additional identification plate delivered loose. | • | • | • | • | • | • | • | • | • | • | • | • | • | • | • | • |
| 159 | Additional plate with text "Made in ..." | • | • | • | • | • | • | • | • | • | • | • | • | • | • | • | • |
| 160 | Additional rating plate affixed. | • | • | • | • | • | • | • | • | • | • | • | • | • | • | • | • |
| 161 | Additional rating plate delivered loose. | • | • | • | • | • | • | • | • | • | • | • | • | • | • | • | • |
| 163 | Frequency converter rating plate. Rating data according to quotation. | • | • | • | • | • | • | • | • | • | • | • | • | • | • | • | • |
| 181 | Rating plate with ABB standard loadability values for VSD operation. Other auxiliaries for VSD operation to be selected as necessary. | - | - | - | - | - | - | - | - | - | - | - | • | • | • | • | • |
| 528 | Rating plate sticker | • | • | • | • | • | • | - | - | - | - | - | • | • | • | • | • |
| Shaft & rotor | | | | | | | | | | | | | | | | | |
| 069 | Two shaft extensions according to catalog drawings. | • | • | • | • | • | • | • | • | • | • | • | • | • | • | • | • |
| 070 | Special shaft extension at D-End, standard shaft material | - | • | • | • | • | • | • | • | • | • | • | • | • | • | • | • |
| 131 | Motor delivered with half key (key not exceeding shaft diameter) | • | • | • | • | • | • | • | • | • | • | • | - | - | - | - | - |
| 155 | Cylindrical shaft extension, D-end, without key-way. | • | • | • | • | • | • | • | • | • | • | • | • | • | • | • | • |
| 164 | Shaft extension with closed keyway | ○ | ○ | ○ | ○ | ○ | ○ | ○ | ○ | ○ | ○ | ○ | • | • | • | • | • |
| 165 | Shaft extension with open keyway | - | - | - | - | - | - | • | • | • | • | • | ○ | ○ | ○ | ○ | ○ |
| 410 | Shaft material stainless steel | • | • | • | • | • | • | • | • | • | • | • | • | • | • | • | • |
| 591 | Special shaft extension according to customer specification. | • | • | • | • | • | • | • | • | • | • | • | • | • | • | • | • |
| 600 | Special shaft extension at N-end, standard shaft material. | • | • | • | • | • | • | • | • | • | • | • | • | • | • | • | • |
| 630 | Shaft material certificate 3.1/3.2 according to EN10204:2004 | - | - | - | - | - | • | • | • | • | • | • | • | • | • | • | • |
| Standards and Regulations | | | | | | | | | | | | | | | | | |
| 010 | Fulfilling CSA Safety Certificate. | - | - | - | - | - | - | • | • | • | • | • | • | • | • | • | • |

○ = Included as standard | • = Available as option | - = Not applicable

| Code/Variants | Frame size | | | | | | | | | | | | | | | | | |
|-------------------------------------------|-----------------------------------------------------------------------------------------------------|----|----|-----|-----|-----|-----|-----|-----|-----|-----|-----|-----|-----|-----|-----|---|---|
| | 71 | 80 | 90 | 100 | 112 | 132 | 160 | 180 | 200 | 225 | 250 | 280 | 315 | 355 | 400 | 450 | | |
| 242 | Fulfilling CSA Energy Efficiency Verification IE2 (code 010 included) | - | - | - | - | - | - | • | • | • | • | • | - | - | - | - | - | |
| 331 | IE1 motor not for sale for use in EU | • | • | • | • | • | • | • | • | • | • | • | • | • | • | • | • | |
| 408 | Fulfilling EISA Subtype II efficiency requirements, CC031A. | - | • | • | • | • | • | • | • | • | • | • | • | • | - | - | - | |
| 500 | Fulfilling Korean MEPS efficiency regulations | - | - | - | - | - | - | • | • | • | • | • | • | • | • | - | - | |
| 540 | China energy label | • | • | • | • | • | • | • | • | • | • | • | • | • | • | - | - | |
| 542 | NBR design | - | - | - | - | - | - | • | • | • | • | • | • | • | • | - | - | |
| 543 | Australian MEPS | - | • | • | • | • | • | • | • | • | • | • | • | • | • | - | - | |
| 548 | Certificate of conformity according TR-CU 004/2011 for customs union RU, KZ, BY. | • | • | • | • | • | • | • | • | • | • | • | • | • | • | • | • | |
| Stator winding temperature sensors | | | | | | | | | | | | | | | | | | |
| 120 | KTY 84-130 (1 per phase) in stator winding. | - | - | - | - | - | - | • | • | • | • | • | • | • | • | • | • | |
| 121 | Bimetal detectors, break type (NCC), (3 in series), 130 °C, in stator winding | • | • | • | • | • | • | • | • | • | • | • | • | • | • | • | • | |
| 122 | Bimetal detectors, break type (NCC), (3 in series), 150 °C, in stator winding | • | • | • | • | • | • | • | • | • | • | • | • | • | • | • | • | |
| 123 | Bimetal detectors, break type (NCC), (3 in series), 170 °C, in stator winding | • | • | • | • | • | • | • | • | • | • | • | • | • | • | • | • | |
| 124 | Bimetal detectors, break type (NCC), (3 in series), 140 °C, in stator winding | - | - | - | - | - | - | • | • | • | • | • | • | • | • | • | • | |
| 125 | Bimetal detectors, break type (NCC), (2x3 in series), 150 °C, in stator winding | - | - | - | - | - | - | • | • | • | • | • | • | • | • | • | • | |
| 127 | Bimetal detectors, break type (NCC), (3 in series, 130 °C & 3 in series, 150 °C), in stator winding | • | • | • | • | • | • | • | • | • | • | • | • | • | • | • | • | |
| 435 | PTC - thermistors (3 in series), 130 °C, in stator winding | • | • | • | • | • | • | • | • | • | • | • | • | • | • | • | • | |
| 437 | PTC - thermistors (3 in series), 170 °C, in stator winding | • | • | • | • | • | • | • | • | • | • | • | • | • | • | • | • | |
| 438 | PTC - thermistors (3 in series), 190 °C, in stator winding | - | - | - | - | - | - | - | - | - | - | - | • | • | • | • | • | |
| 439 | PTC - thermistors (2x3 in series), 150 °C, in stator winding | • | • | • | • | • | • | • | • | • | • | • | • | • | • | • | • | |
| 441 | PTC - thermistors (3 in series, 130 °C & 3 in series, 150 °C), in stator winding | • | • | • | • | • | • | • | • | • | • | • | • | • | • | • | • | |
| 442 | PTC - thermistors (3 in series, 150 °C & 3 in series, 170 °C), in stator winding | • | • | • | • | • | • | • | • | • | • | • | • | • | • | • | • | |
| 445 | Pt100 2-wire in stator winding, 1 per phase | • | • | • | • | • | • | • | • | • | • | • | • | • | • | • | • | |
| 446 | Pt100 2-wire in stator winding, 2 per phase | - | - | - | - | - | - | • | • | • | • | • | • | • | • | • | • | |
| 502 | Pt100 3-wire in stator winding, 1 per phase | - | - | - | - | - | - | • | • | • | • | • | • | • | • | • | • | |
| 503 | Pt100 3-wire in stator winding, 2 per phase | - | - | - | - | - | - | • | • | • | • | • | • | • | • | • | • | |
| 511 | PTC thermistors (2 x 3 in series), 130 °C, in stator winding | - | - | - | - | - | - | • | • | • | • | • | • | • | • | • | • | |
| 515 | Pt100 3-wire in stator winding, 3 per phase | - | - | - | - | - | - | - | - | - | - | - | • | • | • | • | • | |
| Terminal box | | | | | | | | | | | | | | | | | | |
| 015 | Motor supplied in D connection. | • | • | • | • | • | • | • | • | • | • | • | - | - | - | - | - | |
| 017 | Motor supplied in Y connection. | • | • | • | • | • | • | • | • | • | • | • | - | - | - | - | - | |
| 019 | Larger than standard terminal box. | • | • | • | • | • | • | - | - | - | - | - | • | • | • | • | • | |
| 020 | Detached terminal box. | - | - | - | - | - | - | - | - | - | - | - | • | • | • | • | • | |
| 021 | Terminal box LHS (seen from D-end). | • | • | • | • | • | • | • | • | • | • | • | • | • | • | • | • | |
| 022 | Cable entry LHS (seen from D-end). | • | • | • | • | • | • | • | • | • | • | • | • | • | • | • | • | |
| 157 | Terminal box degree of protection IP65. | - | - | - | - | - | - | • | • | • | • | • | • | • | • | • | • | |
| 180 | Terminal box RHS (seen from D-end). | • | • | • | • | • | • | • | • | • | • | • | • | • | • | • | • | |
| 230 | Standard metal cable gland. | • | • | • | • | • | • | • | • | • | • | • | • | • | • | ○ | ○ | ○ |
| 231 | Cable entry with clamping device. | - | - | - | - | - | - | - | - | - | - | - | • | • | • | • | • | |
| 277 | Cable sealing end unit, size small for C-opening | - | - | - | - | - | - | - | - | - | - | - | • | - | - | - | - | |
| 278 | Cable sealing end unit, size medium for D-opening | - | - | - | - | - | - | - | - | - | - | - | • | • | • | • | • | |
| 279 | Cable sealing end unit, size large for D-opening | - | - | - | - | - | - | - | - | - | - | - | • | • | • | • | • | |
| 292 | Adapter C-C | - | - | - | - | - | - | - | - | - | - | - | • | - | - | - | - | |
| 293 | Adapter D-D | - | - | - | - | - | - | - | - | - | - | - | • | • | • | • | • | |
| 294 | Adapter E-D | - | - | - | - | - | - | - | - | - | - | - | • | • | • | • | • | |
| 295 | Adapter E-2D | - | - | - | - | - | - | - | - | - | - | - | • | • | • | ○ | ○ | |
| 296 | Adapter E-3D | - | - | - | - | - | - | - | - | - | - | - | • | • | • | • | • | |
| 351 | Terminal block turned according to cable entry | - | - | - | - | - | - | - | - | - | - | - | • | • | - | • | • | |
| 375 | Standard plastic cable gland | • | • | • | • | • | • | - | - | - | - | - | - | - | - | - | - | |
| 380 | Separate terminal box for temperature detectors, std. material | - | - | - | - | - | - | • | • | • | • | • | • | • | • | • | • | |
| 400 | 4 x 90 degr turnable terminal box. | • | • | • | • | • | • | ○ | ○ | ○ | ○ | ○ | ○ | ○ | ○ | - | - | |
| 413 | Extended cable connection, no terminal box. | - | - | - | - | - | - | - | - | - | - | - | • | • | • | • | • | |
| 418 | Separate terminal box for auxiliaries, standard material. | • | • | • | • | • | • | • | • | • | • | • | • | • | • | • | • | |
| 444 | Adapter E-2E | - | - | - | - | - | - | - | - | - | - | - | - | - | - | - | • | |
| 447 | Top mounted separate terminal box for monitoring equipment. | - | - | - | - | - | - | - | - | - | - | - | • | • | • | • | • | |
| 466 | Terminal box at N-end. | - | - | - | - | - | - | • | • | • | • | • | • | • | • | • | • | |
| 467 | Lower than standard terminal box and rubber extended cable. Cable length 2 m | - | - | - | - | - | - | • | • | • | • | • | - | - | - | - | - | |
| 468 | Cable entry from D-end. | • | • | • | • | • | • | - | - | - | - | - | • | • | • | • | • | |
| 469 | Cable entry from N-end. | • | • | • | • | • | • | • | • | • | • | • | • | • | • | • | - | |
| 526 | Existing cable entries plugged | ○ | ○ | ○ | ○ | ○ | ○ | ○ | ○ | ○ | ○ | ○ | ○ | ○ | ○ | • | - | |
| 553 | Terminal box degree of protection IP66. | • | • | • | • | • | • | • | • | • | • | • | • | • | • | • | • | |
| 554 | Painted steel flange for cable glands drilled and tapped according to order. | - | • | • | • | • | • | • | • | • | • | • | • | • | • | • | • | |
| 555 | Aluminum flange for cable glands drilled and tapped according to order. | - | • | • | • | • | • | • | • | • | • | • | • | • | • | • | • | |
| 557 | Nickel plated cable glands mounted according to order. | - | • | • | • | • | • | • | • | • | • | • | • | • | • | • | • | |
| 567 | Separate terminal box material: cast Iron | - | - | - | - | - | - | ○ | ○ | ○ | ○ | ○ | • | • | • | • | • | |

○ = Included as standard | • = Available as option | - = Not applicable

| Code/Variants | Frame size | | | | | | | | | | | | | | | |
|--------------------------------------------------------------------------------------------------------------------------------------------|------------|----|----|-----|-----|-----|-----|-----|-----|-----|-----|-----|-----|-----|-----|-----|
| | 71 | 80 | 90 | 100 | 112 | 132 | 160 | 180 | 200 | 225 | 250 | 280 | 315 | 355 | 400 | 450 |
| 568 Separate terminal box for heating elements, std. material | - | - | - | - | - | - | • | • | • | • | • | • | • | • | • | • |
| 569 Separate terminal box for brakes | - | - | - | - | - | - | - | - | - | - | - | • | • | • | • | • |
| 624 Prepared for BSP cable glands. | - | • | • | • | • | • | • | • | • | • | • | • | • | • | • | - |
| 727 Stainless steel flange for cable glands drilled and tapped according to order. | - | - | - | - | - | - | • | • | • | • | • | • | • | • | • | • |
| 729 Aluminum non-drilled flange for cable glands | - | - | - | - | - | - | • | • | • | • | • | • | • | • | • | • |
| 730 Prepared for NPT cable glands. | • | • | • | • | • | • | • | • | • | • | • | • | • | • | • | • |
| 731 Two standard metal cable glands. | • | • | • | • | • | • | • | • | • | • | • | • | • | ○ | ○ | ○ |
| 740 Prepared for PG cable glands. | - | - | - | - | - | - | • | • | • | • | • | • | - | - | - | - |
| 742 Protective cover for accessory terminal block in main terminal box. | - | - | - | - | - | - | - | - | - | - | - | - | - | - | - | - |
| 743 Painted non-drilled flange in steel for cable glands | - | - | - | - | - | - | • | • | • | • | • | • | • | • | • | • |
| 744 Stainless steel non-drilled flange for cable glands. | - | - | - | - | - | - | • | • | • | • | • | • | • | • | • | • |
| 745 Painted steel flange equipped with nickel plated brass cable glands | - | - | - | - | - | - | • | • | • | • | • | • | • | • | • | • |
| 746 Stainless steel cable flange equipped with standard nickel plated brass cable glands | - | - | - | - | - | - | • | • | • | • | • | • | • | • | • | • |
| Testing | | | | | | | | | | | | | | | | |
| 140 Test confirmation. | ○ | ○ | ○ | ○ | ○ | ○ | • | • | • | • | • | - | - | - | - | - |
| 145 Type test report from a catalogue motor, 400V 50Hz. | • | • | • | • | • | • | • | • | • | • | • | • | • | • | • | • |
| 146 Type test with report for one motor from specific delivery batch. | • | • | • | • | • | • | • | • | • | • | • | • | • | • | • | • |
| 148 Routine test report. | • | • | • | • | • | • | • | • | • | • | • | • | • | • | • | • |
| 150 Customer witnessed testing. Specify test procedure with other codes. | • | • | • | • | • | • | • | • | • | • | • | • | • | • | • | • |
| 153 Reduced test for classification society. | - | - | - | - | - | - | • | • | • | • | - | - | - | - | - | - |
| 222 Torque/speed curve, type test and multi-point load test with report for one motor from specific delivery batch. | • | • | • | • | • | • | • | • | • | • | • | • | • | • | • | • |
| 560 Shaft voltage test. | • | • | • | • | • | • | • | • | • | • | • | • | • | • | • | • |
| 561 Overspeed test. | • | • | • | • | • | • | • | • | • | • | • | • | • | • | • | • |
| 562 Overvoltage test. | • | • | • | • | • | • | • | • | • | • | • | • | • | • | • | • |
| 760 Vibration level test | • | • | • | • | • | • | • | • | • | • | • | • | • | • | • | • |
| 761 Vibration spectrum test for one motor from specific delivery batch. | - | - | - | - | - | - | • | • | • | • | • | • | • | • | • | • |
| 762 Noise level test for one motor from specific delivery batch. | • | • | • | • | • | • | • | • | • | • | • | • | • | • | • | • |
| 763 Noise spectrum test for one motor from specific delivery batch. | - | - | - | - | - | - | • | • | • | • | • | • | • | • | • | • |
| 764 Test for one motor from specific delivery batch with ABB frequency converter available at ABB test field. ABB standard test procedure. | - | - | - | - | - | - | • | • | • | • | • | • | • | • | • | • |
| Variable speed drives | | | | | | | | | | | | | | | | |
| 429 Separate motor cooling (fan top, N-end) and 1024 pulse tacho (Leine & Linde 861) mounted. | - | - | - | - | - | - | - | - | - | - | - | - | • | • | • | • |
| 470 Prepared for hollow shaft pulse tacho (L&L equivalent). | - | - | - | - | - | - | • | • | • | • | • | • | • | • | • | • |
| 472 1024 pulse tacho (L&L 861007455-1024). | - | - | - | - | • | • | • | • | • | • | • | • | • | • | • | • |
| 473 2048 pulse tacho (L&L 861007455-2048). | - | - | - | - | • | • | • | • | • | • | • | • | • | • | • | • |
| 474 Separate motor cooling (axial fan, N-end) and prepared for hollow shaft tacho (L&L equivalent) | - | - | - | - | - | - | • | • | • | • | • | • | • | • | • | • |
| 476 Separate motor cooling (axial fan, N-end) and 1024 pulse tacho (L&L 861007455-1024) | - | - | - | - | - | - | • | • | • | • | • | • | • | • | • | • |
| 477 Separate motor cooling (axial fan, N-end) and 2048 pulse tacho (L&L 861007455-2048) | - | - | - | - | - | - | • | • | • | • | • | • | • | • | • | • |
| 478 Separate motor cooling (fan on top, N-end) and prepared for hollow shaft tacho (L&L equivalent) | - | - | - | - | - | - | - | - | - | - | - | - | • | • | • | • |
| 479 Mounting of other type of pulse tacho with shaft extension, tacho not included. | - | - | - | - | - | - | - | - | - | - | - | - | • | • | • | • |
| 486 Separate motor cooling (fan top, N-end) and prepared for DC-tacho. | - | - | - | - | - | - | - | - | - | - | - | - | • | • | • | • |
| 510 Separate motor cooling (fan top, N-end) and 2048 pulse tacho (Leine & Linde 861) mounted. | - | - | - | - | - | - | - | - | - | - | - | - | • | • | • | • |
| 582 1024 pulse tacho, GHK912-GBR-1024, BEI IDEACOD | - | - | - | - | - | - | - | - | - | - | - | - | • | • | • | • |
| 583 2048 pulse tacho, GHK912-GBR-2048, BEI IDEACOD | - | - | - | - | - | - | - | - | - | - | - | - | • | • | • | • |
| 658 Special tacho mounted, price category 1 | - | - | - | - | - | - | - | - | - | - | - | - | • | • | • | • |
| 659 Special tacho mounted, price category 2 | - | - | - | - | - | - | - | - | - | - | - | - | • | • | • | • |
| 660 Special tacho mounted, price category 3 | - | - | - | - | - | - | - | - | - | - | - | - | • | • | • | • |
| 701 Insulated bearing at N-end. | - | - | - | - | - | - | • | • | • | • | • | • | • | • | • | • |
| 704 EMC cable entry. | • | • | • | • | • | • | • | • | • | • | • | • | • | • | • | • |
| Y/D starting | | | | | | | | | | | | | | | | |
| 117 Terminals for Y/D start at both speeds (two speed windings). | - | - | - | - | - | - | • | • | • | • | • | • | • | • | - | - |
| 118 Terminals for Y/D start at high speed (two speed windings). | - | - | - | - | - | - | - | - | - | - | - | - | • | • | - | - |
| 119 Terminals for Y/D start at low speed (two speed windings). | - | - | - | - | - | - | - | - | - | - | - | - | • | • | - | - |

○ = Included as standard | • = Available as option | - = Not applicable

Mechanical design

Motor frame and drain holes

Motor frame

The motor frame is made of cast iron, and the standard design includes cast iron feet, bearing housing, and terminal box. Integrated cast iron feet provide rigid mounting and minimize vibration.

Motors can be supplied for foot mounting, flange mounting, and combinations of these.

Drain holes

Motors that will be operated in very humid or wet environments, and especially under intermittent duty, should be provided with drain holes. The IM designation, such as IM 3031, determines the intended mounting arrangement for the motor.

Motor sizes 71 - 450 are fitted with drain holes and closable plugs. The plugs are open on delivery. When mounting the motors, ensure that the drain holes face downwards.

In the case of vertical mounting, the upper plug must be hammered home completely. In very dusty environments, both plugs should be hammered home.

When mounting arrangement differs from foot mounted IM B3, mention variant code 066 when ordering.

See variant codes 065 and 066 under the heading "Drain holes".

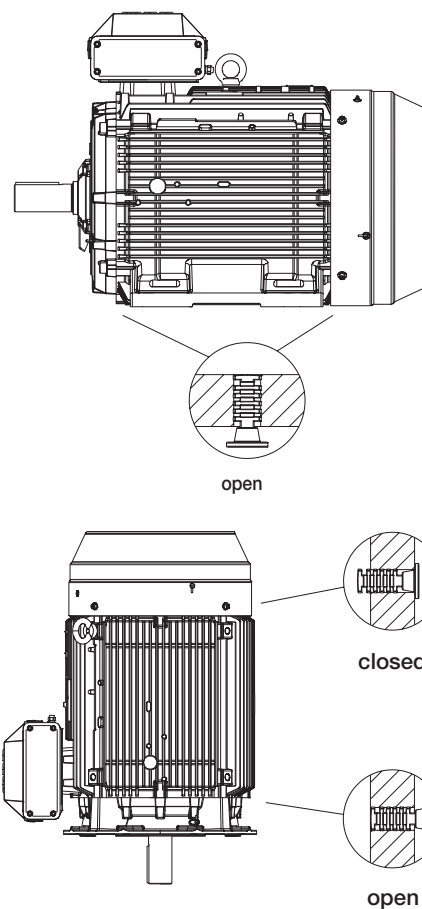

As standard, motor sizes 71 - 450 are delivered with drain holes and closable plugs.

Heating elements

Heating elements are installed into windings to keep them free of corrosion in humid conditions. The required power of heating elements is shown in the table. You can order heating elements with variant code 450 or 451.

| Motor size | 71 | 80 | 90 | 100 | 112 | 132 | 160 | 180 |
|------------|----|----|----|-----|-----|-----|-----|-----|
| Power (W) | 8 | 8 | 25 | 25 | 25 | 25 | 25 | 50 |

| Motor size | 200 | 225 | 250 | 280 | 315 | 355 | 400 | 450 |
|------------|-----|-----|-----|-----|------|------|------|-------|
| Power (W) | 50 | 50 | 50 | 60 | 2x60 | 2x60 | 2x60 | 2x100 |

Bearings

Process performance motors are normally fitted with single-row deep-groove ball bearings, as shown in the table below.

If the bearing at the D-end is replaced with a roller bearing (NU- or NJ-), higher radial forces can be handled. Roller bearings are suitable for belt-drive applications and can be ordered with variant code 037.

When high axial forces are involved, angular-contact ball bearings should be used. When ordering a motor with an angular-contact ball bearing, specify also the method of mounting and the direction and magnitude of axial force. The variant codes for ordering angular-contact ball bearings are 058 and 059.

Standard and alternative designs

| | | Standard design | | Alternative designs | | |
|------------|-----------------|---------------------------|------------|-----------------------|---------------------------------------|--------|
| | | Deep groove ball bearings | | Roller bearings (037) | Ang. contact ball bearings (058, 059) | |
| Motor size | Number of poles | D-end | N-end | D-end | D-end | N-end |
| 71 | 2 - 8 | 6203-2Z/C3 | 6202-2Z/C3 | NU 203 ECP/C3 | 7203 B | 7202 B |
| 80 | 2 - 8 | 6204-2Z/C3 | 6203-2Z/C3 | NU 204 ECP/C3 | 7204 B | 7203 B |
| 90 | 2 - 8 | 6205-2Z/C3 | 6204-2Z/C3 | NU 205 ECP/C3 | 7205 B | 7204 B |
| 100 | 2 - 8 | 6206-2Z/C3 | 6205-2Z/C3 | NU 206 ECP/C3 | 7206 B | 7205 B |
| 112 | 2 - 8 | 6206-2Z/C3 | 6205-2Z/C3 | NU 206 ECP/C3 | 7206 B | 7205 B |
| 132 | 2 - 8 | 6208-2Z/C3 | 6208-2Z/C3 | NU 208 ECP/C3 | 7208 B | 7208 B |
| 160 | 2 - 12 | 6309/C3 | 6209/C3 | NU 309 ECP/C3 | 7309 B | 7209 B |
| 180 | 2 - 12 | 6310/C3 | 6209/C3 | NU 310 ECP/C3 | 7310 B | 7209 B |
| 200 | 2 - 12 | 6312/C3 | 6210/C3 | NU 312 ECP/C3 | 7312 B | 7210 B |
| 225 | 2 - 12 | 6313/C3 | 6212/C3 | NU 313 ECP/C3 | 7313 B | 7212 B |
| 250 | 2 - 12 | 6315/C3 | 6213/C3 | NU 315 ECP/C3 | 7315 B | 7213 B |
| 280 | 2 | 6316/C3 | 6316/C3 | ¹⁾ | 7316 B | 7616 B |
| | 4 - 12 | 6316/C3 | 6316/C3 | NU 316 ECP/C3 | 7316 B | 7316 B |
| 315 | 2 | 6316/C3 | 6316/C3 | ¹⁾ | 7316 B | 7316 B |
| | 4 - 12 | 6319/C3 | 6316/C3 | NU 319 ECP/C3 | 7319 B | 7316 B |
| 355 | 2 | 6316M/C3 | 6316M/C3 | ¹⁾ | 7316 B | 7316 B |
| | 4 - 12 | 6322/C3 | 6316/C3 | NU 322 ECP/C3 | 7322 B | 7316 B |
| 400 | 2 | 6317M/C3 | 6317M/C3 | ¹⁾ | 7317 B | 7317 B |
| | 4 - 12 | 6324/C3 | 6319/C3 | NU 324 ECP/C3 | 7324 B | 7319 B |
| 450 | 2 | 6317M/C3 | 6317M/C3 | ¹⁾ | 7317 B | 7317 B |
| | 4 - 12 | 6326M/C3 | 6322/C3 | NU 326 ECP/C3 | 7326 B | 7322 B |

¹⁾ On request

Axially-locked bearings

All motors are equipped as standard with an axially locked bearing at the D-end.

Transport locking

Motors with roller bearings or an angular-contact ball bearing are fitted with a transport lock before dispatch to prevent damage to bearings during transport. A warning sign is attached to motors larger than 250 when transport locking is used.

Locking may also be fitted in other cases if severe transport conditions are expected.

Bearing seals

These tables present the standard and alternative sizes and types of bearing seals per motor size.

Bearing seals for motor sizes 71 – 250

| Motor size | Number of poles | Standard design | | Alternative design |
|------------|-----------------|-----------------|----------------|---------------------------------|
| | | Axial seal | | Radial seal at D-end (DIN 3760) |
| | | D-end | N-end | Variant code 072 |
| 71 | 2 - 12 | VA16 | Labyrinth seal | 17x28x7 |
| 80 | 2 - 12 | VA20 | Labyrinth seal | 20x40x7 |
| 90 | 2 - 12 | VA25 | Labyrinth seal | 25x42x7 |
| 100 | 2 - 12 | VA30 | Labyrinth seal | 30x47x7 |
| 112 | 2 - 12 | VA30 | Labyrinth seal | 30x47x7 |
| 132 | 2 - 12 | VA40 | VA40 | 40x62x7 |
| 160 | 2 - 12 | RB45 | RB45 | 45x62x8 |
| 180 | 2 - 12 | RB50 | RB45 | 50x68x8 |
| 200 | 2 - 12 | RB60 | RB50 | 60x80x8 |
| 225 | 2 - 12 | RB65 | RB60 | 65x85x10 |
| 250 | 2 - 12 | RB75 | RB65 | 75x95x10 |

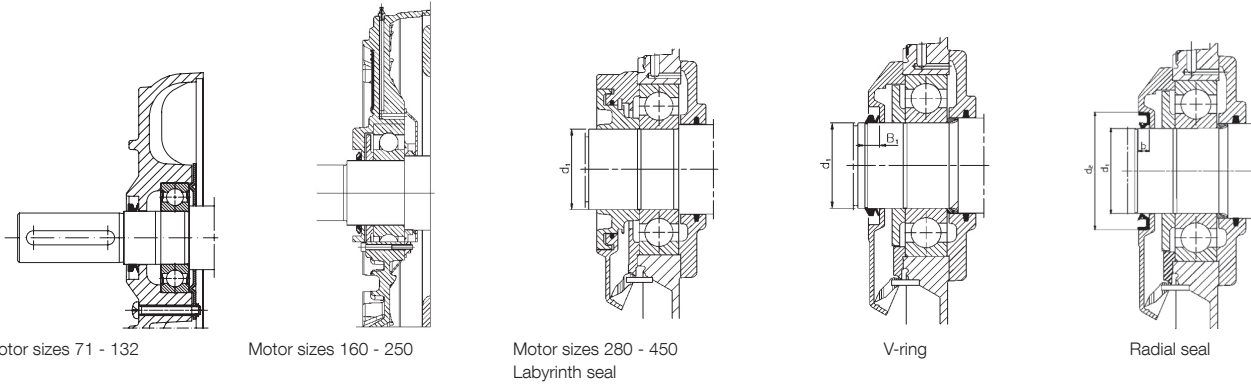

Bearing seals for motor sizes 280 - 450

| Motor size | Number of poles | Standard design | | Alternative design | |
|------------|-----------------|-----------------|----------------|-----------------------|-----------------------|
| | | D-end | N-end | D-end | N-end |
| 280 | 2 | Labyrinth seal | VS80 | - | Labyrinth seal |
| 280 | 4 - 12 | VS80 | VS80 | Labyrinth seal | Labyrinth seal |
| | 4 - 12 | | | Radial seal 80x110x10 | Radial seal 80x110x10 |
| 315 | 2 | Labyrinth seal | VS80 | - | Labyrinth seal |
| 315 SM, ML | 4 - 12 | VS95 | VS80 | Labyrinth seal | Labyrinth seal |
| | 4 - 12 | | | Radial seal 95x125x10 | Radial seal 80x110x10 |
| 315 LK | 4 - 12 | Labyrinth seal | VS80 | - | Labyrinth seal |
| | 4 - 12 | | | - | Radial seal 80x110x10 |
| 355 | 2 | Labyrinth seal | VS80 | - | Labyrinth seal |
| 355 | 4 - 12 | Labyrinth seal | VS80 | - | Labyrinth seal |
| 400 | 2 | Labyrinth seal | Labyrinth seal | - | - |
| 400 | 4 - 12 | Labyrinth seal | VS95 | - | Labyrinth seal |
| 450 | 2 | Labyrinth seal | Labyrinth seal | - | - |
| 450 | 4 - 12 | Labyrinth seal | Labyrinth seal | - | - |

Table is valid for IE2 motors
 Axial seal:
 RB45...75 = Gamma-ring
 VA16...65 = V-ring, type A
 VS80...95 = V-ring, type S

Bearing life and lubrication

Bearing life

The nominal life L_{10h} of a bearing is defined according to ISO 281 as the number of operating hours achieved or exceeded by 90 % of identical bearings in a large test series under specified conditions. 50 % of bearings achieve at least five times this lifetime.

The calculated bearing life L_{10h} for power transmission by means of coupling is for horizontally mounted motors in sizes 280 to 315 $\geq 200,000$ hours.

Lubrication

On delivery, motors in frame size 160 and above are prelubricated with high-quality grease. Before first start-up, see instructions for relubrication and recommended grease in the Manual for low voltage motors delivered together with the motor, or see the lubrication plate on the motor.

Motors with bearings greased for life

Motors in frame sizes 71 - 132 are equipped with bearings greased for life, while this is available as an option for frame sizes 160 - 250. Bearings are lubricated with high-quality, high-temperature grease. Bearing types are stated on the rating plate.

The approximate lifetime of bearings in four-pole motors is about 40 0000 duty hours. Lifetime is subject to the load conditions of the application run by the motor.

Lubrication intervals

ABB follows the L_1 principle in defining lubrication intervals. This means that 99 % of motors will make the interval time.

The lubrication intervals can also be calculated according to the L_{10} principle, which usually gives twice as long interval times. L_{10} values are available from ABB at request.

Motors with relubrication nipples

In frame sizes 280 - 450, the bearing system allows the use of a valve disc to ease lubrication. Motors are lubricated while running. The grease outlet opening has closing valves at both ends. These should be opened before greasing and closed 1 - 2 hours after regreasing. This ensures that the construction is tight and bearings remain dust- and dirt-free.

A grease-collection method can be used optionally.

The following tables show lubrication intervals according to the L_1 principle for various nominal speeds in 25 °C ambient temperature. These values apply to horizontally mounted motors (B3) with 80 °C bearing temperature and high-quality grease containing lithium-complex soap and mineral or PAO-oil.

Lubrication intervals in duty hours for ball bearings

| Frame size | Amount of grease g/bearing | Amount of grease g/N-end | Output kW | Speed 3600 r/min | Speed 3000 r/min | Output kW | Speed 1800 r/min | Speed 1500 r/min | Output kW | Speed 1000 r/min | Output kW | Speed 500-900 r/min |
|--------------------------------------------|----------------------------|--------------------------|-----------|------------------|------------------|-----------|------------------|------------------|-----------|------------------|-----------|---------------------|
| Ball bearings | | | | | | | | | | | | |
| Lubrication intervals in duty hours | | | | | | | | | | | | |
| 160 | 13 | 13 | ≤ 18.5 | 9000 | 12 000 | ≤ 15 | 18 000 | 21 500 | ≤ 11 | 24 000 | all | 24 000 |
| 160 | 13 | 13 | > 18.5 | 7500 | 10 000 | > 15 | 15 000 | 18 000 | > 11 | 22 500 | all | 24 000 |
| 180 | 15 | 15 | ≤ 22 | 7000 | 9000 | ≤ 22 | 15 500 | 18 500 | ≤ 15 | 24 000 | all | 24 000 |
| 180 | 15 | 15 | > 22 | 6000 | 8500 | > 22 | 14 000 | 17 000 | > 15 | 21 000 | all | 24 000 |
| 200 | 20 | 15 | ≤ 37 | 5500 | 8000 | ≤ 30 | 14 500 | 17 500 | ≤ 22 | 23 000 | all | 24 000 |
| 200 | 20 | 15 | > 37 | 3000 | 5500 | > 30 | 10 000 | 12 000 | > 22 | 16 000 | all | 20 000 |
| 225 | 23 | 20 | ≤ 45 | 4000 | 6500 | ≤ 45 | 13 000 | 16 500 | ≤ 30 | 22 000 | all | 24 000 |
| 250 | 23 | 20 | > 45 | 1500 | 2500 | > 45 | 5000 | 6000 | > 30 | 8000 | all | 10 000 |
| 250 | 30 | 23 | ≤ 55 | 2500 | 4000 | ≤ 55 | 9000 | 11 500 | ≤ 37 | 15 000 | all | 18 000 |
| 250 | 30 | 23 | > 55 | 1000 | 1500 | > 55 | 3500 | 4500 | > 37 | 6000 | all | 7000 |
| 280 | 35 | 35 | all | 1900 | 3200 | - | - | - | - | - | - | - |
| 280 | 40 | 40 | - | - | - | all | 7800 | 9600 | all | 13 900 | all | 15 000 |
| 315 | 35 | 35 | all | 1900 | 3200 | - | - | - | - | - | - | - |
| 315 | 55 | 40 | - | - | - | all | 5900 | 7600 | all | 11 800 | all | 12 900 |
| 355 | 35 | 35 | all | 1900 | 3200 | - | - | - | - | - | - | - |
| 355 | 70 | 40 | - | - | - | all | 4000 | 5600 | all | 9600 | all | 10 700 |
| 400 | 40 | 40 | all | 1500 | 2700 | - | - | - | - | - | - | - |
| 400 | 85 | 55 | - | - | - | all | 3200 | 4700 | all | 8600 | all | 9700 |
| 450 | 40 | 40 | all | 1500 | 2700 | - | - | - | - | - | - | - |
| 450 | 95 | 70 | - | - | - | all | 2500 | 3900 | all | 7700 | all | 8700 |

Lubrication intervals in duty hours for roller bearings

| Frame size | Amount of grease g/bearing | Amount of grease g/N-end | Output kW | Speed 3600 r/min | Speed 3000 r/min | Output kW | Speed 1800 r/min | Speed 1500 r/min | Output kW | Speed 1000 r/min | Output kW | Speed 500-900 r/min |
|--------------------------------------------|----------------------------|--------------------------|-----------|------------------|------------------|-----------|------------------|------------------|-----------|------------------|-----------|---------------------|
| Roller bearings | | | | | | | | | | | | |
| Lubrication intervals in duty hours | | | | | | | | | | | | |
| 160 | 13 | 13 | ≤ 18.5 | 4500 | 6000 | ≤ 15 | 9000 | 10 500 | ≤ 11 | 12 000 | all | 12 000 |
| 160 | 13 | 13 | > 18.5 | 3500 | 5000 | > 15 | 7500 | 9000 | > 11 | 11 000 | all | 12 000 |
| 180 | 15 | 15 | ≤ 22 | 3500 | 4500 | ≤ 22 | 7500 | 9000 | ≤ 15 | 12 000 | all | 12 000 |
| 180 | 15 | 15 | > 22 | 3000 | 4000 | > 22 | 7000 | 8500 | > 15 | 10500 | all | 12 000 |
| 200 | 20 | 15 | ≤ 37 | 2750 | 4000 | ≤ 30 | 7000 | 8500 | ≤ 22 | 11 500 | all | 12 000 |
| 200 | 20 | 15 | > 37 | 1500 | 2500 | > 30 | 5000 | 6000 | > 22 | 8000 | all | 10 000 |
| 225 | 23 | 20 | ≤ 45 | 2000 | 3000 | ≤ 45 | 6500 | 8000 | ≤ 30 | 11 000 | all | 12 000 |
| 225 | 23 | 20 | > 45 | 750 | 1250 | > 45 | 2500 | 3000 | > 30 | 4000 | all | 5000 |
| 250 | 30 | 23 | ≤ 55 | 1000 | 2000 | ≤ 55 | 4500 | 5500 | ≤ 37 | 7500 | all | 9000 |
| 250 | 30 | 23 | > 55 | 500 | 750 | > 55 | 1500 | 2000 | > 37 | 3000 | all | 3500 |
| 280 | 35 | 35 | all | 900 | 1600 | - | - | - | - | - | - | - |
| 280 | 40 | 40 | - | - | - | all | 4000 | 5300 | all | 7000 | all | 8500 |
| 315 | 35 | 35 | all | 900 | 1600 | - | - | - | - | - | - | - |
| 315 | 55 | 40 | - | - | - | all | 2900 | 3800 | all | 5900 | all | 6500 |
| 355 | 35 | 35 | all | 900 | 1600 | - | - | - | - | - | - | - |
| 355 | 70 | 40 | - | - | - | all | 2000 | 2800 | all | 4800 | all | 5400 |
| 400 | 40 | 40 | all | - | 1300 | - | - | - | - | - | - | - |
| 400 | 85 | 55 | - | - | - | all | 1600 | 2400 | all | 4300 | all | 4800 |
| 450 | 40 | 40 | all | - | 1300 | - | - | - | - | - | - | - |
| 450 | 95 | 70 | - | - | - | all | 1300 | 2000 | all | 3800 | all | 4400 |

Radial forces

Permissible loading on the shaft

The following table shows permissible radial forces on the shaft in Newtons, assuming zero axial force, a 25 °C ambient temperature, and normal conditions. The values are given for a calculated bearing life of 20 000 and 40 000 hours per motor size.

These calculated values further assume mounting position IM B3 (foot-mounted), with force directed sideways. In some cases, the strength of the shaft affects permissible forces.

Permissible loads of simultaneous radial and axial forces can be supplied on request.

If the radial force is applied between points X0 and Xmax, the permissible force FR can be calculated with the following formula:

$$F_R = F_{X0} - \frac{X}{E} (F_{X0} - F_{Xmax})$$

Where:

E: length of the shaft extension in the standard version

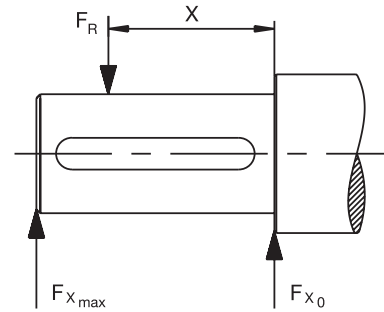

Permissible radial forces, motor sizes 71 – 132

| Motor size | No. of poles | Length of shaft extension E (mm) | Basic design with deep groove ball bearings | | | | Roller bearings | | | |
|------------|--------------|----------------------------------|---------------------------------------------|--------------|----------------|--------------|----------------------------|--------------|----------------|------|
| | | | Mounting arrangement IM B3 | | | | Mounting arrangement IM B3 | | | |
| | | | 20,000 h | | 40,000 h | | 20,000 h | | 40,000 h | |
| | | F_{X0} (N) | F_{Xmax} (N) | F_{X0} (N) | F_{Xmax} (N) | F_{X0} (N) | F_{Xmax} (N) | F_{X0} (N) | F_{Xmax} (N) | |
| 71 | 2 | 30 | 540 | 460 | 420 | 360 | 1285 | 650 | 1040 | 650 |
| | 4 | 30 | 700 | 605 | 555 | 480 | 1615 | 650 | 1310 | 650 |
| | 6 | 30 | 780 | 665 | 620 | 530 | 1640 | 650 | 1450 | 650 |
| | 8 | 30 | 860 | 730 | 685 | 580 | 1640 | 600 | 1580 | 600 |
| 80 | 2 | 40 | 710 | 600 | 385 | 350 | 1910 | 865 | 1555 | 865 |
| | 4 | 40 | 940 | 810 | 725 | 625 | 2335 | 865 | 1945 | 865 |
| | 6 | 40 | 1060 | 895 | 840 | 710 | 2335 | 865 | 2160 | 865 |
| | 8 | 40 | 1185 | 1020 | 940 | 810 | 2335 | 865 | 2335 | 865 |
| 90 | 2 | 50 | 820 | 690 | 650 | 545 | 2205 | 1330 | 1790 | 1330 |
| | 4 | 50 | 1035 | 870 | 820 | 690 | 2715 | 1330 | 2205 | 1330 |
| | 6 | 50 | 1185 | 995 | 940 | 790 | 3065 | 1330 | 2490 | 1330 |
| | 8 | 50 | 1300 | 1095 | 1035 | 870 | 3340 | 1330 | 2715 | 1330 |
| 100 | 2 | 60 | 1130 | 925 | 900 | 735 | 2905 | 1900 | 2360 | 1900 |
| | 4 | 60 | 1425 | 1165 | 1135 | 925 | 3575 | 1900 | 2905 | 1900 |
| | 6 | 60 | 1635 | 1335 | 1295 | 1060 | 4040 | 1900 | 3280 | 1900 |
| | 8 | 60 | 1820 | 1520 | 1445 | 1205 | 4460 | 1900 | 3620 | 1900 |
| 112 | 2 | 60 | 1170 | 980 | 925 | 775 | 3000 | 1970 | 2435 | 1970 |
| | 4 | 60 | 1475 | 1235 | 1170 | 980 | 3695 | 1970 | 3000 | 1970 |
| | 6 | 60 | 1690 | 1310 | 1340 | 1120 | 4170 | 1970 | 3390 | 1970 |
| | 8 | 60 | 1860 | 1310 | 1475 | 1235 | 4550 | 1970 | 3695 | 1970 |
| 132 | 2 | 80 | 1840 | 1500 | 1460 | 1190 | 4255 | 3465 | 3455 | 2815 |
| | 4 | 80 | 2320 | 1890 | 1840 | 1500 | 5240 | 4265 | 4255 | 3465 |
| | 6 | 80 | 2660 | 2165 | 2110 | 1715 | 5915 | 3680 | 4805 | 3680 |
| | 8 | 80 | 2925 | 2380 | 2320 | 1890 | 6450 | 3680 | 5240 | 3680 |

Permissible radial forces, motor sizes 160 - 280

| Motor size | Poles | Length of shaft extension E (mm) | Ball bearings | | | | Roller bearings | | | |
|------------|-------|-------------------------------------|---------------|---------------|-------------|---------------|-----------------|---------------|-------------|---------------|
| | | | 20,000 h | | 40,000 h | | 20,000 h | | 40,000 h | |
| | | | $F_{x0}(N)$ | $F_{xmax}(N)$ | $F_{x0}(N)$ | $F_{xmax}(N)$ | $F_{x0}(N)$ | $F_{xmax}(N)$ | $F_{x0}(N)$ | $F_{xmax}(N)$ |
| 160 MLA | 2 | 110 | 3540 | 2740 | 2955 | 2285 | 7100 | 4300 | 6140 | 4300 |
| | 4 | 110 | 4000 | 3100 | 3325 | 2570 | 8000 | 4300 | 6870 | 4300 |
| | 6 | 110 | 4170 | 3200 | 3440 | 2655 | 8600 | 4300 | 7270 | 4300 |
| | 8 | 110 | 4600 | 3585 | 3855 | 2985 | 9300 | 4300 | 7955 | 4300 |
| 160 MLB | 2 | 110 | 3540 | 2740 | 2955 | 2270 | 7085 | 4300 | 6070 | 4300 |
| | 4 | 110 | 4085 | 3300 | 3370 | 2725 | 8300 | 4300 | 7055 | 4300 |
| | 6 | 110 | 4100 | 3355 | 3400 | 2755 | 8600 | 4300 | 7300 | 4300 |
| | 8 | 110 | 4200 | 3270 | 3455 | 2670 | 9000 | 4300 | 7570 | 4300 |
| 160 MLC | 2 | 110 | 3400 | 2600 | 2855 | 2200 | 6800 | 4300 | 5885 | 4300 |
| | 4 | 110 | 3700 | 3000 | 3070 | 2485 | 7800 | 4300 | 6640 | 4300 |
| | 6 | 110 | 3600 | 2900 | 2870 | 2325 | 8000 | 4300 | 6700 | 4300 |
| | 8 | 110 | 4170 | 3370 | 3370 | 2725 | 9000 | 4300 | 7585 | 4300 |
| 160 MLD | 2 | 110 | 3585 | 2900 | 3000 | 2440 | 7100 | 4300 | 6140 | 4300 |
| | 4 | 110 | 3400 | 2755 | 2755 | 2240 | 7600 | 4300 | 6370 | 4300 |
| 160 MLE | 2 | 110 | 3185 | 2570 | 2640 | 2140 | 6785 | 4300 | 5770 | 4300 |
| 180 MLA | 2 | 110 | 4100 | 3385 | 3455 | 2825 | 8125 | 5500 | 7025 | 5500 |
| | 4 | 110 | 4270 | 3485 | 3525 | 2885 | 8600 | 5500 | 7300 | 5500 |
| | 6 | 110 | 4700 | 3800 | 3855 | 3155 | 9400 | 5500 | 7900 | 5500 |
| | 8 | 110 | 4785 | 3900 | 3870 | 3170 | 9800 | 5500 | 8255 | 5500 |
| 180 MLB | 2 | 110 | 4170 | 3400 | 3470 | 2825 | 7900 | 5500 | 6770 | 5500 |
| | 4 | 110 | 4185 | 3400 | 3440 | 2810 | 8500 | 5500 | 7200 | 5500 |
| | 6 | 110 | 4370 | 3570 | 3525 | 2885 | 9000 | 5500 | 7600 | 5500 |
| 180 MLC | 4 | 110 | 3700 | 3055 | 3010 | 2470 | 7900 | 5500 | 6655 | 5440 |
| 200 MLA | 2 | 110 | 5600 | 4685 | 4700 | 3925 | 10900 | 9100 | 9470 | 7900 |
| | 4 | 110 | 6285 | 5200 | 5240 | 4370 | 12500 | 9550 | 10700 | 8900 |
| | 6 | 110 | 6800 | 5700 | 5700 | 4770 | 13600 | 9550 | 11670 | 9550 |
| | 8 | 110 | 6800 | 5700 | 5600 | 4685 | 14100 | 9550 | 12000 | 9550 |
| 200 MLB | 2 | 110 | 5670 | 4700 | 4700 | 3925 | 11000 | 9200 | 9500 | 7900 |
| | 4 | 110 | 5700 | 4700 | 4700 | 3925 | 12000 | 9550 | 10185 | 8500 |
| | 6 | 110 | 6400 | 5370 | 5300 | 4425 | 13200 | 9550 | 11200 | 9385 |
| 200 MLC | 2 | 110 | 5000 | 4185 | 4185 | 3500 | 10400 | 8700 | 8900 | 7455 |
| | 4 | 110 | 5400 | 4500 | 4425 | 3685 | 11600 | 9550 | 9800 | 8200 |
| | 6 | 110 | 5800 | 4885 | 4740 | 3955 | 12500 | 9550 | 10600 | 8800 |
| 200 MLD | 2 | 110 | 4985 | 4170 | 4170 | 3485 | 10400 | 8700 | 8900 | 7400 |
| 225 SMA | 2 | 110 | 6400 | 5400 | 5355 | 4500 | 13300 | 10700 | 11500 | 9700 |
| | 4 | 140 | 7300 | 5900 | 6155 | 4970 | 15400 | 10250 | 13200 | 10250 |
| | 6 | 140 | 7600 | 6200 | 6370 | 5140 | 16400 | 10250 | 14000 | 10250 |
| | 8 | 140 | 8500 | 6900 | 7100 | 5725 | 17900 | 10250 | 15300 | 10250 |
| 225 SMB | 2 | 110 | 6100 | 5185 | 5155 | 4340 | 13000 | 10700 | 11200 | 9455 |
| | 4 | 140 | 7085 | 5700 | 5885 | 4755 | 15100 | 10250 | 12900 | 10250 |
| | 6 | 140 | 7100 | 5700 | 5840 | 4700 | 16000 | 10250 | 13500 | 10250 |
| | 8 | 140 | 8000 | 6485 | 6600 | 5340 | 17300 | 10250 | 14700 | 10250 |
| 225 SMC | 2 | 110 | 5600 | 4700 | 4685 | 3940 | 12600 | 10600 | 10770 | 9070 |
| | 4 | 140 | 6400 | 5200 | 5300 | 4285 | 14500 | 10250 | 12385 | 10000 |
| 225 SMD | 2 | 110 | 5500 | 4640 | 4600 | 3880 | 12420 | 10460 | 10640 | 8960 |
| | 4 | 140 | 5800 | 4700 | 4725 | 3800 | 13500 | 10250 | 11400 | 9270 |
| 250 SMA | 2 | 140 | 7700 | 6285 | 6500 | 5285 | 17100 | 10900 | 14900 | 10900 |
| | 4 | 140 | 8700 | 7000 | 7300 | 5900 | 19800 | 13800 | 17000 | 13785 |
| | 6 | 140 | 9400 | 7600 | 7800 | 6355 | 21600 | 13800 | 18400 | 13800 |
| | 8 | 140 | 9600 | 7800 | 7900 | 6400 | 22700 | 13800 | 19300 | 13800 |
| 250 SMB | 2 | 140 | 7100 | 5800 | 6000 | 4885 | 16700 | 10900 | 14400 | 10900 |
| | 4 | 140 | 7800 | 6300 | 6470 | 5240 | 18900 | 13800 | 16200 | 13100 |
| | 6 | 140 | 8900 | 7200 | 7355 | 5955 | 21200 | 13800 | 18000 | 13800 |
| 250 SMC | 2 | 140 | 6800 | 5500 | 5670 | 4600 | 16300 | 10900 | 14000 | 10900 |
| | 4 | 140 | 7400 | 6000 | 6055 | 4900 | 18100 | 13800 | 15400 | 12485 |
| | 6 | 140 | 8200 | 6600 | 6670 | 5400 | 20300 | 13800 | 17200 | 13800 |
| 280 SM_ | 2 | 140 | 7300 | 6000 | 5800 | 4900 | 20400 | 6000 | 16500 | 6000 |
| | 4 | 140 | 9200 | 7800 | 7300 | 6200 | 25100 | 9200 | 20300 | 9200 |
| | 6 | 140 | 10600 | 8900 | 8400 | 7000 | 28300 | 9200 | 23000 | 9200 |
| | 8 | 140 | 11700 | 9200 | 9200 | 7800 | 30900 | 9200 | 25100 | 9200 |
| 280 ML_ | 2 | 140 | 7400 | 6200 | 5800 | 5000 | 20600 | 6200 | 16700 | 6200 |
| | 4 | 140 | 9200 | 7900 | 7300 | 6200 | 25000 | 9500 | 20300 | 9500 |
| | 6 | 140 | 10500 | 9000 | 8300 | 7100 | 28300 | 9400 | 22900 | 9400 |
| | 8 | 140 | 11600 | 9500 | 9200 | 7900 | 30800 | 9500 | 25000 | 9500 |

Permissible radial forces, motor sizes 315 - 450

| Motor size | Poles | Length of shaft extension E (mm) | Ball bearings | | | | Roller bearings | | | |
|---------------------|-------|-------------------------------------|---------------|----------------|--------------|----------------|-----------------|----------------|--------------|----------------|
| | | | 20,000 h | | 40,000 h | | 20,000 h | | 40,000 h | |
| | | | F_{x0} (N) | F_{xmax} (N) | F_{x0} (N) | F_{xmax} (N) | F_{x0} (N) | F_{xmax} (N) | F_{x0} (N) | F_{xmax} (N) |
| 315 SM ₋ | 2 | 140 | 7300 | 6000 | 5800 | 4950 | 20300 | 6000 | 16500 | 6000 |
| | 4 | 170 | 11400 | 9400 | 9000 | 7450 | 32500 | 9600 | 26600 | 9600 |
| | 6 | 170 | 13000 | 9600 | 10300 | 8500 | 37000 | 9600 | 30000 | 9600 |
| | 8 | 170 | 14400 | 9600 | 11400 | 9400 | 40300 | 9600 | 32700 | 9600 |
| 315 ML ₋ | 2 | 140 | 7400 | 6400 | 5850 | 5050 | 20600 | 5850 | 16700 | 5850 |
| | 4 | 170 | 11500 | 9700 | 9100 | 7650 | 32700 | 13600 | 26500 | 13600 |
| | 6 | 170 | 13200 | 11100 | 10400 | 8800 | 36900 | 13600 | 29900 | 13600 |
| | 8 | 170 | 14500 | 12200 | 11500 | 9700 | 40200 | 13600 | 32600 | 13600 |
| 315 LK ₋ | 2 | 140 | 7400 | 6550 | 5800 | 5150 | 20800 | 5550 | 16800 | 5550 |
| | 4 | 170 | 11500 | 10000 | 9100 | 7850 | 33100 | 13350 | 26800 | 13350 |
| | 6 | 170 | 13200 | 11400 | 10450 | 9050 | 37300 | 13350 | 30300 | 13350 |
| | 8 | 170 | 14600 | 12600 | 11550 | 10000 | 40800 | 13350 | 33100 | 13350 |
| 355 SM ₋ | 2 | 140 | 7350 | 6450 | 5750 | 5050 | 20600 | 7200 | 16700 | 7200 |
| | 4 | 210 | 15200 | 12600 | 12000 | 9950 | 45500 | 14000 | 36900 | 14000 |
| | 6 | 210 | 17500 | 14000 | 13800 | 11400 | 51400 | 14000 | 41700 | 14000 |
| | 8 | 210 | 19300 | 14000 | 15250 | 12600 | 56000 | 14000 | 45500 | 14000 |
| 355 ML ₋ | 2 | 140 | 7350 | 6550 | 5750 | 5100 | 20800 | 6750 | 16800 | 6750 |
| | 4 | 210 | 15300 | 12900 | 12000 | 10100 | 45900 | 13600 | 37200 | 13600 |
| | 6 | 210 | 17600 | 13600 | 13900 | 11600 | 51500 | 13600 | 42100 | 13600 |
| | 8 | 210 | 19400 | 13600 | 15300 | 12900 | 56000 | 13600 | 45900 | 13600 |
| 355 LK ₋ | 2 | 140 | 7350 | 6650 | 5650 | 5100 | 21000 | 6550 | 17000 | 6550 |
| | 4 | 210 | 15200 | 13000 | 11850 | 10200 | 46000 | 13000 | 37300 | 13000 |
| | 6 | 210 | 17500 | 13000 | 13700 | 11900 | 52000 | 13000 | 42000 | 13000 |
| | 8 | 210 | 19400 | 13000 | 15200 | 13000 | 56500 | 13000 | 46000 | 13000 |
| 400 L ₋ | 2 | 170 | 7650 | 6850 | 4400 | 3900 | 23900 | 9050 | 19350 | 9050 |
| | 4 | 210 | 15600 | 13550 | 12150 | 10550 | 52500 | 16000 | 43300 | 16000 |
| | 6 | 210 | 17800 | 15450 | 13850 | 12000 | 60000 | 16000 | 48800 | 16000 |
| | 8 | 210 | 19700 | 16000 | 15350 | 13350 | 65700 | 16000 | 53200 | 16000 |
| 400 LK ₋ | 2 | 170 | 7650 | 6850 | 4400 | 3900 | 23900 | 9050 | 19350 | 9050 |
| | 4 | 210 | 15600 | 11500 | 12150 | 10550 | 52500 | 11500 | 43300 | 11500 |
| | 6 | 210 | 17800 | 11500 | 13850 | 11500 | 60000 | 11500 | 48800 | 11500 |
| | 8 | 210 | 19700 | 11500 | 15350 | 11500 | 65700 | 11500 | 53200 | 11500 |
| 450 L ₋ | 2 | 170 | 7400 | 6700 | 3500 | 3300 | 24000 | 7500 | 19000 | 7500 |
| | 4 | 210 | 17000 | 15200 | 13000 | 11600 | 62000 | 25000 | 50000 | 25000 |
| | 6 | 210 | 19000 | 17000 | 14000 | 13000 | 70000 | 24000 | 56000 | 24000 |
| | 8 | 210 | 21300 | 19000 | 16500 | 14600 | 76000 | 23000 | 62000 | 23000 |

Axial forces

The following tables present permissible axial forces on the shaft in Newtons, assuming zero radial force, a 25 °C ambient temperature, and normal conditions. The values are given for a calculated bearing life of 20,000 and 40,000 hours per motor size.

At 60 Hz, the values must be reduced by 10 percent, and for two-speed motors, the higher speed determines permissible axial force. Permissible loads of simultaneous radial and axial forces can be supplied on request.

For axial force F_{AD} , it is assumed that the D-bearing is locked with a locking ring.

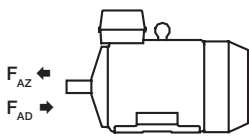

Mounting arrangement IM B3

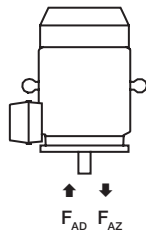

Mounting arrangement IM V1

Permissible axial forces, motor sizes 71 - 132

| Motor size | Poles | Length of shaft extension E (mm) | Mounting arrangement IM B3 | | | | Mounting arrangement IM V1 | | | |
|------------|-------|----------------------------------|----------------------------|-------------|-------------|-------------|----------------------------|-------------|-------------|-------------|
| | | | Deep groove ball bearings | | | | Deep groove ball bearings | | | |
| | | | 20,000 h | | 40,000 h | | 20,000 h | | 40,000 h | |
| | | | $F_{AD}(N)$ | $F_{AZ}(N)$ | $F_{AD}(N)$ | $F_{AZ}(N)$ | $F_{AD}(N)$ | $F_{AZ}(N)$ | $F_{AD}(N)$ | $F_{AZ}(N)$ |
| 71 | 2 | 30 | 615 | 285 | 505 | 175 | 630 | 275 | 520 | 165 |
| | 4 | 30 | 760 | 430 | 615 | 285 | 790 | 410 | 645 | 265 |
| | 6 | 30 | 870 | 540 | 695 | 365 | 890 | 525 | 720 | 355 |
| | 8 | 30 | 960 | 630 | 765 | 435 | 985 | 615 | 785 | 415 |
| 80 | 2 | 40 | 880 | 300 | 735 | 155 | 915 | 280 | 770 | 135 |
| | 4 | 40 | 1075 | 495 | 880 | 300 | 1130 | 455 | 935 | 260 |
| | 6 | 40 | 1215 | 635 | 985 | 405 | 1270 | 600 | 1040 | 370 |
| | 8 | 40 | 1330 | 750 | 1070 | 490 | 1400 | 705 | 1140 | 450 |
| 90 | 2 | 50 | 780 | 500 | 620 | 340 | 840 | 455 | 680 | 300 |
| | 4 | 50 | 985 | 705 | 775 | 495 | 1070 | 650 | 860 | 440 |
| | 6 | 50 | 1140 | 860 | 890 | 610 | 1225 | 800 | 975 | 555 |
| | 8 | 50 | 1265 | 985 | 985 | 705 | 1355 | 925 | 1075 | 645 |
| 100 | 2 | 60 | 925 | 570 | 735 | 350 | 1285 | 510 | 1060 | 290 |
| | 4 | 60 | 1480 | 860 | 1190 | 570 | 1600 | 780 | 1305 | 490 |
| | 6 | 60 | 1690 | 1070 | 1350 | 730 | 1815 | 995 | 1470 | 650 |
| | 8 | 60 | 1865 | 1245 | 1480 | 860 | 1995 | 1160 | 1610 | 775 |
| 112 | 2 | 60 | 1155 | 595 | 935 | 375 | 1290 | 505 | 1070 | 280 |
| | 4 | 60 | 1445 | 885 | 1155 | 595 | 1595 | 785 | 1300 | 495 |
| | 6 | 60 | 1655 | 1095 | 1315 | 755 | 1810 | 995 | 1465 | 650 |
| | 8 | 60 | 1830 | 1270 | 1445 | 885 | 1985 | 1170 | 1600 | 780 |
| 132 | 2 | 80 | 1765 | 965 | 1420 | 620 | 1925 | 855 | 1580 | 510 |
| | 4 | 80 | 2210 | 1410 | 1755 | 955 | 2420 | 1270 | 1965 | 815 |
| | 6 | 80 | 2535 | 1735 | 2000 | 1200 | 2770 | 1580 | 2235 | 1045 |
| | 8 | 80 | 2800 | 2000 | 2205 | 1405 | 3055 | 1835 | 2455 | 1235 |

Permissible axial forces, motor sizes 160 - 280

| Motor size | Poles | Length of shaft extension E (mm) | Mounting arrangement IM B3 | | | | Mounting arrangement IM V1 | | | |
|------------|-------|----------------------------------|----------------------------|---------------------|---------------------|---------------------|----------------------------|---------------------|---------------------|---------------------|
| | | | Deep groove ball bearings | | | | Deep groove ball bearings | | | |
| | | | 20,000 h | | 40,000 h | | 20,000 h | | 40,000 h | |
| | | | F _{AD} (N) | F _{AZ} (N) | F _{AD} (N) | F _{AZ} (N) | F _{AD} (N) | F _{AZ} (N) | F _{AD} (N) | F _{AZ} (N) |
| 160 MLA | 2 | 110 | 2850 | 2850 | 2325 | 2325 | 3100 | 2578 | 2570 | 2048 |
| | 4 | 110 | 3450 | 3450 | 2775 | 2775 | 3820 | 3150 | 3120 | 2450 |
| | 6 | 110 | 3690 | 3690 | 2970 | 2970 | 4100 | 3410 | 3325 | 2635 |
| | 8 | 110 | 4155 | 4155 | 3315 | 3315 | 4440 | 3845 | 3640 | 3045 |
| 160 MLB | 2 | 110 | 2850 | 2850 | 2325 | 2325 | 3120 | 2570 | 2580 | 2030 |
| | 4 | 110 | 3435 | 3435 | 2760 | 2760 | 3880 | 3085 | 3180 | 2385 |
| | 6 | 110 | 3600 | 3600 | 2880 | 2880 | 4120 | 3240 | 3360 | 2480 |
| | 8 | 110 | 3750 | 3750 | 2970 | 2970 | 4140 | 3450 | 3340 | 2650 |
| 160 MLC | 2 | 110 | 2775 | 2775 | 2280 | 2280 | 3080 | 2500 | 2560 | 1980 |
| | 4 | 110 | 3150 | 3150 | 2535 | 2535 | 3620 | 2770 | 2985 | 2135 |
| | 6 | 110 | 3135 | 3135 | 2490 | 2490 | 3680 | 2700 | 3005 | 2025 |
| | 8 | 110 | 3675 | 3675 | 2910 | 2910 | 4240 | 3260 | 3445 | 2465 |
| 160 MLD | 2 | 110 | 2865 | 2865 | 2330 | 2330 | 3220 | 2540 | 2665 | 1985 |
| | 4 | 110 | 2900 | 2900 | 2320 | 2320 | 3420 | 2470 | 2820 | 1870 |
| 160 MLE | 2 | 110 | 2500 | 2500 | 2025 | 2025 | 2900 | 2150 | 2420 | 1670 |
| 180 MLA | 2 | 110 | 3300 | 3300 | 2700 | 2700 | 3660 | 2940 | 3060 | 2340 |
| | 4 | 110 | 3600 | 3600 | 2920 | 2920 | 4160 | 3150 | 3460 | 2450 |
| | 6 | 110 | 4140 | 4140 | 3320 | 3320 | 4800 | 3675 | 3940 | 2815 |
| | 8 | 110 | 4220 | 4220 | 3360 | 3360 | 4960 | 3740 | 4040 | 2820 |
| 180 MLB | 2 | 110 | 3340 | 3340 | 2725 | 2725 | 3760 | 2960 | 3125 | 2320 |
| | 4 | 110 | 3580 | 3580 | 2900 | 2900 | 4220 | 3095 | 3500 | 2375 |
| | 6 | 110 | 3800 | 3800 | 3040 | 3040 | 4500 | 3285 | 3700 | 2485 |
| 180 MLC | 4 | 110 | 3220 | 3220 | 2560 | 2560 | 3880 | 2660 | 3220 | 2000 |
| 200 MLA | 2 | 110 | 4460 | 4460 | 3640 | 3640 | 5000 | 3965 | 4200 | 3125 |
| | 4 | 110 | 5000 | 5260 | 4260 | 4260 | 5000 | 4680 | 5000 | 3640 |
| | 6 | 110 | 5000 | 5480 | 4720 | 4720 | 5000 | 5265 | 5000 | 4065 |
| | 8 | 110 | 5000 | 5880 | 4700 | 4700 | 5000 | 5195 | 5000 | 3955 |
| 200 MLB | 2 | 110 | 4440 | 4440 | 3620 | 3620 | 5000 | 3905 | 4220 | 3085 |
| | 4 | 110 | 4720 | 4720 | 3840 | 3840 | 5000 | 4060 | 4700 | 3120 |
| | 6 | 110 | 5000 | 5480 | 4420 | 4420 | 5000 | 4800 | 5000 | 3660 |
| 200 MLC | 2 | 110 | 3940 | 3940 | 3180 | 3180 | 4600 | 3385 | 3880 | 2665 |
| | 4 | 110 | 4480 | 4480 | 3620 | 3620 | 5000 | 3775 | 4520 | 2875 |
| | 6 | 110 | 4980 | 4980 | 3980 | 3980 | 5000 | 4165 | 5000 | 3105 |
| 200 MLD | 2 | 110 | 3940 | 3940 | 3200 | 3200 | 4660 | 3370 | 3925 | 2635 |
| 225 SMA | 2 | 110 | 4980 | 4980 | 4060 | 4060 | 5000 | 4375 | 4780 | 3455 |
| | 4 | 140 | 5000 | 6080 | 4920 | 4920 | 5000 | 5445 | 5000 | 4225 |
| | 6 | 140 | 5000 | 6520 | 5000 | 5260 | 5000 | 5735 | 5000 | 4395 |
| | 8 | 140 | 5000 | 7420 | 5000 | 5960 | 5000 | 6535 | 5000 | 5095 |
| 225 SMB | 2 | 110 | 4860 | 4860 | 3960 | 3960 | 5000 | 4245 | 4780 | 3345 |
| | 4 | 140 | 5000 | 5880 | 4780 | 4780 | 5000 | 5175 | 5000 | 3995 |
| | 6 | 140 | 5000 | 6020 | 4840 | 4840 | 5000 | 5155 | 5000 | 3915 |
| | 8 | 140 | 5000 | 6940 | 5000 | 5560 | 5000 | 6055 | 5000 | 4635 |
| 225 SMC | 2 | 110 | 4380 | 4380 | 3540 | 3540 | 5000 | 3670 | 4440 | 2900 |
| | 4 | 140 | 5000 | 5240 | 4260 | 4260 | 5000 | 4445 | 5000 | 3425 |
| 225 SMD | 2 | 110 | 4320 | 4320 | 3480 | 3480 | 5000 | 3590 | 4400 | 2790 |
| | 4 | 140 | 4800 | 4800 | 3820 | 3820 | 5000 | 3895 | 5000 | 2935 |
| 250 SMA | 2 | 140 | 6000 | 6080 | 4920 | 4920 | 6000 | 5345 | 5840 | 4225 |
| | 4 | 140 | 6000 | 7140 | 5820 | 5820 | 6000 | 6300 | 6000 | 4920 |
| | 6 | 140 | 6000 | 7880 | 6000 | 6380 | 6000 | 6950 | 6000 | 5350 |
| | 8 | 140 | 6000 | 8200 | 6000 | 6600 | 6000 | 7125 | 6000 | 5385 |
| 250 SMB | 2 | 140 | 5620 | 5620 | 4540 | 4540 | 6000 | 4830 | 5640 | 3810 |
| | 4 | 140 | 6000 | 6320 | 5100 | 5100 | 6000 | 5325 | 6000 | 4085 |
| | 6 | 140 | 6000 | 7480 | 6000 | 6040 | 6000 | 6370 | 6000 | 4830 |
| 250 SMC | 2 | 140 | 5260 | 5260 | 4220 | 4220 | 6000 | 4395 | 5400 | 3415 |
| | 4 | 140 | 5960 | 5960 | 4760 | 4760 | 6000 | 4900 | 6000 | 3700 |
| | 6 | 140 | 6000 | 6860 | 5520 | 5520 | 6000 | 5575 | 6000 | 4135 |
| 280 SM_ | 2 | 140 | 6200 | 4250 | 4900 | 2900 | 7550 | 3150 | 6200 | 1800 |
| | 4 | 140 | 8000 | 6000 | 6250 | 4250 | 9600 | 4550 | 7800 | 2750 |
| | 6 | 140 | 7250 | 9250 | 7150 | 5150 | 11150 | 5500 | 9000 | 3350 |
| | 8 | 140 | 10300 | 8300 | 7950 | 5950 | 12200 | 7000 | 9850 | 4700 |
| 280 ML_ | 2 | 140 | 6100 | 4100 | 4800 | 2800 | 8150 | 2750 | 6800 | 1400 |
| | 4 | 140 | 7800 | 5800 | 6000 | 4000 | 10450 | 4050 | 8650 | 2250 |
| | 6 | 140 | 8950 | 6950 | 6900 | 4900 | 12350 | 4750 | 10250 | 2600 |
| | 8 | 140 | 10000 | 8000 | 7700 | 5700 | 13450 | 5800 | 11050 | 3450 |

Permissible axial forces, motor sizes 315 - 450

| Motor size | Poles | Length of shaft extension E (mm) | Mounting arrangement IM B3 | | | | Mounting arrangement IM V1 | | | |
|------------------------|-------|----------------------------------|----------------------------|---------------------|---------------------|---------------------|----------------------------|---------------------|---------------------|---------------------|
| | | | Deep groove ball bearings | | | | Deep groove ball bearings | | | |
| | | | 20,000 h | | 40,000 h | | 20,000 h | | 40,000 h | |
| | | | F _{AD} (N) | F _{AZ} (N) | F _{AD} (N) | F _{AZ} (N) | F _{AD} (N) | F _{AZ} (N) | F _{AD} (N) | F _{AZ} (N) |
| 315 SM ₋ | 2 | 140 | 6180 | 4200 | 4850 | 2850 | 7950 | 2600 | 6600 | 1300 |
| | 4 | 170 | 9400 | 7400 | 7250 | 5250 | 11750 | 5500 | 9550 | 3300 |
| | 6 | 170 | 10900 | 8900 | 8350 | 6350 | 13600 | 6300 | 11050 | 3750 |
| | 8 | 170 | 12000 | 10000 | 9200 | 7000 | 15350 | 7900 | 12450 | 5000 |
| 315 ML ₋ | 2 | 140 | 6050 | 4050 | 4750 | 2750 | 8650 | 2300 | 7300 | ¹⁾ |
| | 4 | 170 | 9250 | 7250 | 7100 | 5100 | 12500 | 5050 | 10300 | 2900 |
| | 6 | 170 | 10650 | 8650 | 8100 | 6100 | 14900 | 5800 | 12350 | 3250 |
| | 8 | 170 | 11500 | 9900 | 8900 | 6800 | 15400 | 6300 | 13600 | 3400 |
| 315 LK ₋ | 2 | 140 | 6000 | 3950 | 4650 | 2650 | 9100 | 1350 | 7750 | ¹⁾ |
| | 4 | 170 | 9100 | 7150 | 7000 | 5000 | 13100 | 3850 | 10900 | 1700 |
| | 6 | 170 | 10500 | 8500 | 7950 | 5950 | 15700 | 4100 | 13100 | 1550 |
| | 8 | 170 | 11750 | 9750 | 8900 | 6900 | 16900 | 6300 | 14100 | 3450 |
| 355 SM ₋ | 2 | 140 | 3050 | 6850 | 1750 | 5550 | 6350 | 4250 | 4950 | 2900 |
| | 4 | 210 | 8600 | 12400 | 5900 | 9700 | 13250 | 8600 | 10450 | 5850 |
| | 6 | 210 | 10550 | 14350 | 7300 | 11100 | 15650 | 9580 | 12350 | 6270 |
| | 8 | 210 | 12200 | 16000 | 8550 | 12350 | 17350 | 12500 | 13600 | 8900 |
| 355 ML ₋ | 2 | 140 | 2900 | 6700 | 1600 | 5400 | 7100 | 3700 | 5750 | 2350 |
| | 4 | 210 | 8360 | 12150 | 5650 | 9450 | 14600 | 7950 | 11850 | 5150 |
| | 6 | 210 | 10100 | 13900 | 6900 | 10700 | 18050 | 8600 | 14700 | 5300 |
| | 8 | 210 | 12000 | 15800 | 7300 | 11000 | 21100 | 11650 | 17000 | 7600 |
| 355 LK ₋ | 2 | 140 | 2650 | 6450 | 1350 | 5150 | 8250 | 2650 | 6900 | 1300 |
| | 4 | 210 | 8200 | 12000 | 5450 | 9250 | 15650 | 6600 | 12850 | 3800 |
| | 6 | 210 | 9900 | 13700 | 6700 | 10500 | 19100 | 7050 | 15800 | 3750 |
| | 8 | 210 | 11450 | 15250 | 7800 | 11600 | 21200 | 8700 | 17500 | 5000 |
| 400 L, LK ₋ | 2 | 170 | 2150 | 7150 | ¹⁾ | 5800 | 8650 | 2150 | 7220 | ¹⁾ |
| | 4 | 210 | 7100 | 13100 | 4300 | 10300 | 16050 | 6400 | 13150 | 3400 |
| | 6 | 210 | 8850 | 14850 | 5500 | 11500 | 18450 | 6750 | 15100 | 3400 |
| | 8 | 210 | 10450 | 16450 | 6750 | 12750 | 20100 | 8350 | 16450 | 4700 |
| 450 L ₋ | 2 | 170 | 1800 | 6800 | ¹⁾ | 5500 | 11500 | ¹⁾ | 10000 | ¹⁾ |
| | 4 | 210 | 7600 | 13500 | 4500 | 10500 | 20000 | 4400 | 17700 | 1200 |
| | 6 | 210 | 9000 | 15000 | 5600 | 11500 | 26000 | 3700 | 22200 | ¹⁾ |
| | 8 | 210 | 10800 | 16800 | 7000 | 12900 | 27800 | 5500 | 23700 | 1350 |

¹⁾ On request.

Terminal box

Standard terminal box

Degree of protection and mounting options

The degree of protection for the standard terminal box is IP 55. By default, terminal boxes are mounted on top of the motor at D-end. In motor sizes 71 - 132, the terminal box is integrated in motor frame. On request, the terminal box can also be mounted on the left or right side regardless of motor size (see Mounting options).

Turnability

In frame sizes 71 to 132 the terminal box is integrated into the frame and can therefore not be turned. Please use the variant code 400 if there is a need to have 4*90° turnability.

The standard terminal boxes for motor sizes 160 to 355 can be turned 4*90°. On frame sizes 400-450 the terminal box can not be turned without turning the terminal board. In these frame sizes you need to specify the cable entry direction when ordering, by using the variant codes 022, 468 or 469.

Cable entries

The terminal box is provided with tapped holes for cable glands. No cable glands are included as standard, the entry holes are closed with blanking plugs made of plastic. Very large motors have angle adapters and cable sealing units as standard. Please refer to the table on the next page for further information about the amount and size of threaded holes, plugs and cable sealing units provided as standard.

Different types of cable glands are available as option. Please refer to the terminal box alternatives section for more details.

Cable type and terminations

If no cable type is specified in the order, it will be a PVC-insulated non-armored cable, and its termination parts are determined as shown in the following table.

Terminations are suitable for copper and aluminum cables (Al-cables on request for motor sizes 160 to 250). Cables are connected to terminals by cable lugs, which are not included in the delivery.

Ordering

To ensure the delivery of desired terminations for the motor, state the cable type, quantity, size, and outer diameter when ordering. Non-standard designs of terminal boxes, such as non-standard size or higher degree of protection, are available as options.

See section Variant codes for all options available.

Standard delivery

Standard delivery if no other information is provided. Note: For other network voltages and/or side-mounted motors, contact your ABB sales office.

| Motor size | Pole number | Terminal box type | Size of gland plate opening on terminal box | 45° angle adapter | Amount and size of threaded plugged holes or cable end sealing unit | Cable outer diameter mm | Max. connectable core cross-section mm ² /phase | Number and size of terminal bolts, |
|-------------------|-------------|-------------------|---------------------------------------------|-------------------|---------------------------------------------------------------------|-------------------------|------------------------------------------------------------|------------------------------------|
| IE2 motors | | | | | | | | |
| 71 | 2-8 | - | - | - | 2xM16x1.5 | 2xØ4-12 | 1x2.5 | 6xM4 |
| 80 | 2-8 | - | - | - | 2xM25x1.5 | 2xØ10-18 | 1x4 | 6xM4 |
| 90 | 2-8 | - | - | - | 2xM25x1.5 | 2xØ10-18 | 1x6 | 6xM5 |
| 100 - 132 | 2-8 | - | - | - | 2xM32x1.5 | 2xØ14-24 | 1x10 | 6xM5 |
| 160 - 180 | 2-8 | 63 | B | - | 2xM40x1.5 | 2xØ22-32 | 1x35 | 6xM6 |
| 200 - 250 | 2-8 | 160 | C | - | 2xM63x1.5 | 2xØ35-45 | 1x70 | 6xM10 |
| 280 SM_ | 2-8 | 210 | C | - | 2xM63x1.5 | 2xØ35-45 | 2x150 | 6xM12 |
| 280 ML_ | 2-4 | 370 | D | - | 2xM63x1.5 | 2xØ35-45 | 2x240 | 6xM12 |
| 280 ML_ | 6-8 | 210 | C | - | 2xM63x1.5 | 2xØ35-45 | 2x150 | 6xM12 |
| 315 SM_ ML_ | 2-8 | 370 | D | - | 2xM63x1.5 | 2xØ35-45 | 2x240 | 6xM12 |
| 315 LKA, LKB | 2-4 | 370 | D | - | 2xM63x1.5 | 2xØ35-45 | 2x240 | 6xM12 |
| 315 LKC | 2-4 | 750 | E | E-D | Medium | 2xØ48-60 | 4x240 | 6xM12 |
| 315 LK_ | 6-8 | 370 | D | - | 2xM63x1.5 | 2xØ35-45 | 2x240 | 6xM12 |
| 355 SMA - SMC | 2-4 | 750 | E | E-D | Medium | 2xØ48-60 | 4x240 | 6xM12 |
| 355 SMA, SMB | 6-8 | 370 | D | - | 2xM63x1.5 | 2xØ35-45 | 2x240 | 6xM12 |
| 355 SMC | 6 | 750 | E | E-D | Medium | 2xØ48-60 | 4x240 | 6xM12 |
| 355 SMC | 8 | 370 | D | - | 2xM63x1.5 | 2xØ35-45 | 2x240 | 6xM12 |
| 355 MLA | 2-4 | 750 | E | E-D | Medium | 2xØ48-60 | 4x240 | 6xM12 |
| 355 MLB, LK_ | 2-4 | 750 | E | E-D | Large | 2xØ60-80 | 4x240 | 6xM12 |
| 355 ML_ LK_ | 6-8 | 750 | E | E-D | Medium | 2xØ48-60 | 4x240 | 6xM12 |
| 400 | 2-6 | 750 | E | E-D | Large | 2xØ60-80 | 4x240 | 6xM12 |
| 400 LA, LB | 8 | 750 | E | E-D | Medium | 2xØ48-60 | 4x240 | 6xM12 |
| 400 LC | 8 | 750 | E | E-D | Large | 2xØ60-80 | 4x240 | 6xM12 |
| 450 LA | 2 | 1200 | E | E-2D | 2 x Large | 4xØ60-80 | 6x240 | 6xM12 |
| 450 LA | 4 | 1200 | E | E-D | Large | 2xØ60-80 | 6x240 | 6xM12 |
| 450 LB, LC | 2-4 | 1200 | E | E-2D | 2 x Large | 4xØ60-80 | 6x240 | 6xM12 |
| 450 LA | 6 | 750 | E | E-D | Large | 2xØ60-80 | 4x240 | 6xM12 |
| 450 LB, LC | 6 | 1200 | E | E-D | Large | 2xØ60-80 | 6x240 | 6xM12 |
| 450 | 8 | 750 | E | E-D | Large | 2xØ60-80 | 4x240 | 6xM12 |

IE3 and IE4 motors

| | | | | | | | | |
|-------------|-----|-----|---|-----|-----------|----------|-------|-----|
| 280 | 2-6 | 210 | C | - | 2xM63x1.5 | 2xØ35-45 | 2x150 | M12 |
| 315 | 2-6 | 370 | D | - | 2xM63x1.5 | 2xØ35-45 | 2x240 | M12 |
| 355 SM_ | 2-4 | 750 | E | E-D | Medium | 2xØ48-60 | 4x240 | M12 |
| 355 SM_ | 6 | 370 | D | - | 2xM63x1.5 | 2xØ35-45 | 2x240 | M12 |
| 355 ML_ LK_ | 2-6 | 750 | E | E-D | Medium | 2xØ48-60 | 4x240 | M12 |

Auxiliary cable entries

| | | | | | | | | |
|-----------|-----|--|--|--|-----------|-------|--|--|
| 160 - 180 | 2-8 | | | | 2xM20x1.5 | Ø4-12 | | |
| 200 - 250 | 2-8 | | | | 2xM20x1.5 | Ø4-12 | | |
| 280 - 450 | 2-8 | | | | 2xM20x1.5 | Ø4-12 | | |

| Motor size | Earthing on frame | Earthing in main terminal box |
|------------|-------------------|-------------------------------|
| 71 - 112 | M4 | M4 |
| 132 | M5 | M5 |
| 160 - 250 | clamp | M6 |
| 280 - 400 | M10 | 2xM10 |
| 450 | M10 | 4xM12 |

Terminal box

Terminal box dimensions

For motor sizes 71 to 132 the terminal box is integrated in motor frame and the dimensions for terminal boxes can be found in the motor dimension drawings in ABB Library.

To match the correct terminal box with motor sizes 160 - 450, find the motor type and correspondent terminal box type on the previous page. The box types and their dimensions are presented on this page.

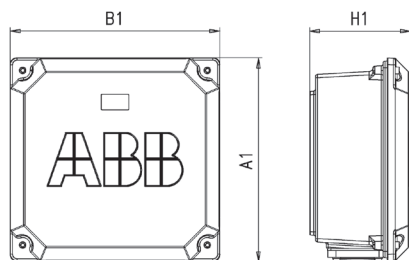

Terminal box type 63 and 160

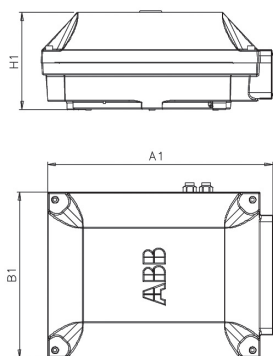

Terminal box types 210 and 370

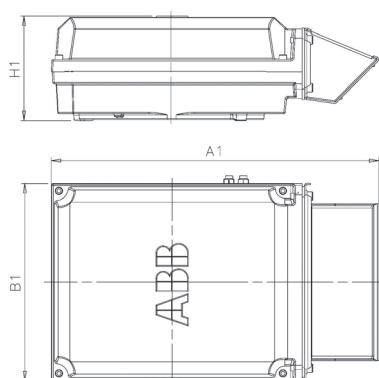

Terminal box type 750 + adapter

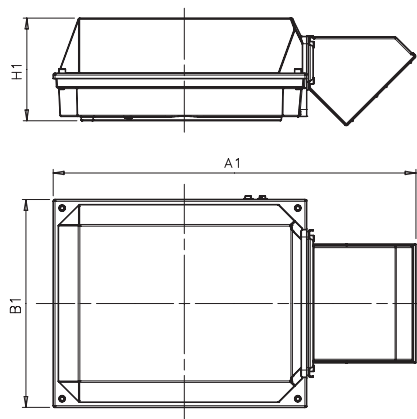

Terminal box type 1200 + adapter

| Terminal box types acc. to current capacity | A1 | B1 | H1 | Gland plate opening |
|---------------------------------------------|------|-----|-----|---------------------|
| 63 | 248 | 248 | 109 | B |
| 160 | 291 | 302 | 154 | C |
| 210 | 416 | 306 | 177 | C |
| 370 | 451 | 347 | 200 | D |
| 750 with E-D adapter | 686 | 413 | 219 | D |
| 750 without E-D adapter | 523 | 413 | 219 | E |
| 1200 with E-2D adapter | 1000 | 578 | 285 | 2xD |
| 1200 without E-2D adapter | 697 | 578 | 285 | E |
| 1200 with E-2E adapter | 1195 | 578 | 285 | 2xE |
| 1200 with E-3D adapter | 1250 | 578 | 285 | 3xD |

Dimensions for terminal box inlets

Corresponds to motor sizes 160 and above

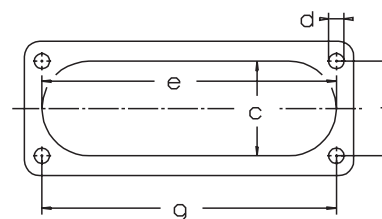

| Flange opening | c mm | e mm | f mm | g mm | d thread type |
|----------------|------|------|------|------|---------------|
| B | 31 | 120 | 30 | 120 | M6 |
| C (*) | 71 | 194 | 62 | 193 | M6 |
| C (**) | 67 | 193 | 62 | 193 | M8 |
| D | 100 | 300 | 80 | 292 | M10 |
| E | 115 | 370 | 100 | 360 | M12 |

Terminal box

Cable glands

The motors are delivered as standard with plugged cable entries or cable sealing units as described in the previous section. There is available a broad selection of different type of cable glands, which are suitable for different types of cable and outer diameter ranges.

| Size of threaded opening for cable gland | Cable gland(s) nickel plated brass, variant code 230 or 731 | EMC Cable gland(s) nickel plated brass, variant code 704 | Cable gland(s) plastic, variant code 375 or 376 |
|------------------------------------------|-------------------------------------------------------------|----------------------------------------------------------|-------------------------------------------------|
| Metric (std) | Cable outer diameter, mm | Cable outer diameter, mm | Cable outer diameter, mm |
| M16 x 1.5 | 4-12 | 4-8 | 4-12 |
| M20 x 1.5 | 4-12 | 4-12 | 4-12 |
| M25 x 1.5 | 10-18 | 10-18 | 10-18 |
| M32 x 1.5 | 14-24 | 14-24 | 14-24 |
| M40 x 1.5 | 22-32 | 22-32 | 22-32 |
| M50 x 1.5 | 26-35 | 26-35 | 26-35 |
| M63 x 1.5 *) | 35-45 | 35-45 | 35-45 |
| M75 x 1.5 | 46-62 | 46-62 | not available |

Threaded openings for cable glands with NPT thread (variant code 730)

The standard delivery for the motors are provided with openings for cable glands with metric threads as listed in the section describing the standard terminal box. If NPT threads will be needed, the variant code 730 is to be ordered. If nothing else is stated on the order, the sizes in tables below will be delivered.

| Motor frame size | Main cable entries | NPT plug |
|------------------|--------------------|------------|
| 80-112 | 1 x 3/4" | - |
| 132 | 2 x 3/4" | 1 x 3/4" |
| 160-180 | 2 x 1 1/4" | 1 x 1 1/4" |
| 200-250 | 2 x 1 1/2" | 1 x 1 1/2" |
| 280 | 2 x 2" | 1 x 2" |
| 315-450 | 2 x 3" | 1 x 3" |

| Motor frame size | Cable entries for auxiliaries | NPT plug |
|------------------|-------------------------------|----------|
| 80-112 | 2 x 3/4" | 2 x 3/4" |
| 132 | 1 x 3/4" | 1 x 3/4" |
| 160-450 | 2 x 3/4" | 2 x 3/4" |

Gland plates with threaded openings for cable glands of nonstandard size

If the standard size of threaded openings for cable glands is not suitable then nonstandard size openings are also available, either by fitting the reducers to make the openings smaller or by increasing the amount or size of holes. The maximum possible size and amount for each gland plate size is listed below. Threaded openings of non-standard size can be ordered by using variant codes 554, 555 and 727.

| Gland plate size | Maximum amount and size of threaded holes |
|------------------|-------------------------------------------|
| B | 2 x M40 |
| C | 2 x M63 |
| D | 2 x M90 or 3 x M75 |
| E | 2 x M90 or 4 x M75 |

Terminal box

Terminal boxes and boards

The pictures below show standard terminal boxes and the corresponding terminal boards for various motor sizes.

Motor sizes 71 - 132

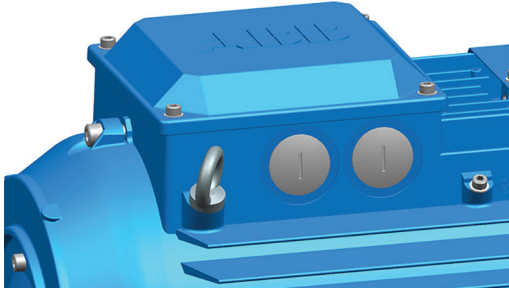

Integrated terminal box for motor sizes 71 - 132. Tapped holes for cable entries.

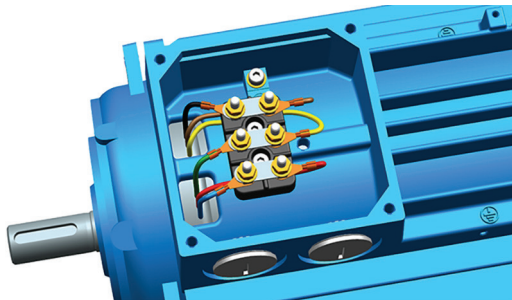

Terminal board for motor sizes 71 - 80.

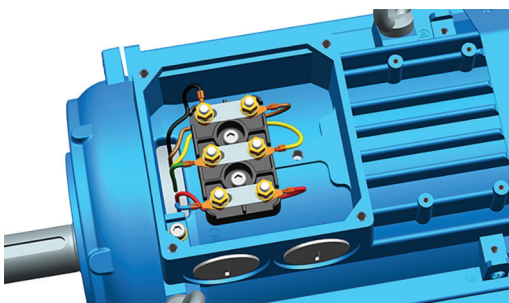

Terminal board for motor sizes 90 - 112, IE2, and 90 - 100, IE3.

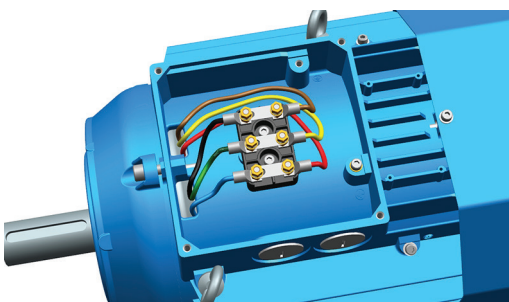

Terminal board for motor size 132, IE2, and motor sizes 112 - 132, IE3.

Motor sizes 160 - 250

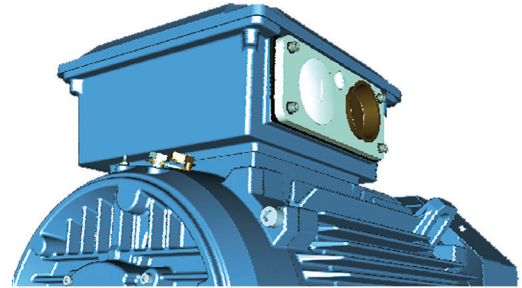

Terminal box for motor sizes 160 - 250. Connection flanges with tapped cable entries.

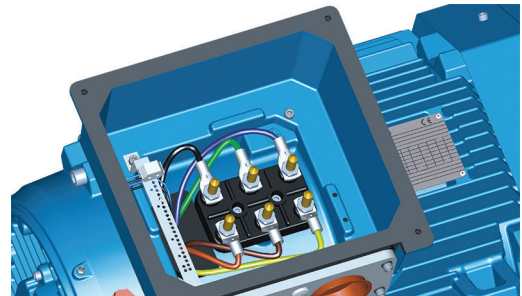

Terminal board for motor sizes 160 - 250.

Motor sizes 280 - 315

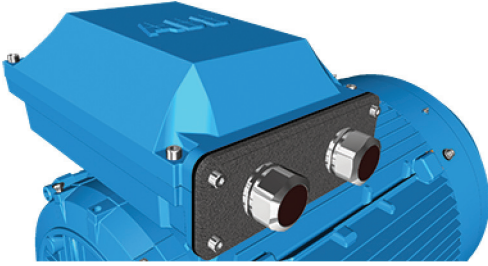

Terminal box for motor sizes 280 - 315, except LKC. Connection flange with tapped cable entries.

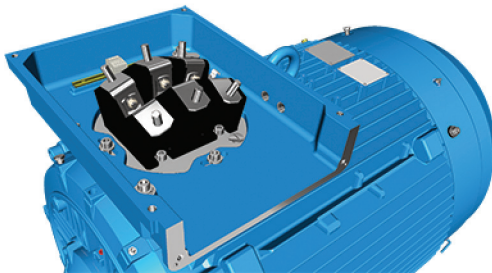

Terminal board for motor sizes 280 - 315, except LKC.

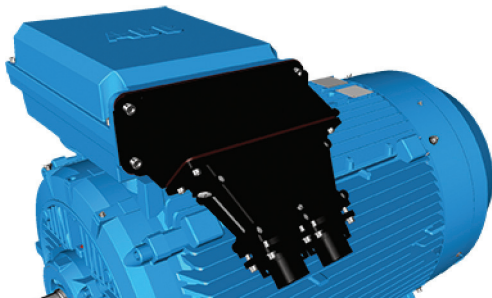

Terminal box for motor sizes 315 LKC and 355 - 400. Adapter and cable sealing end unit.

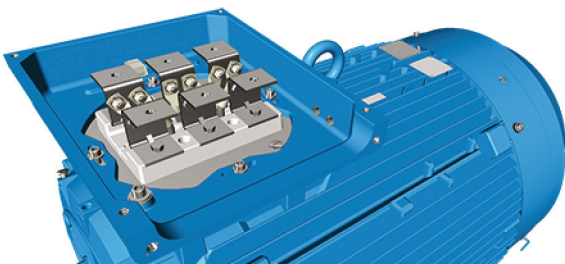

Terminal board for motor sizes 315 LKC and 355 - 400.

Motor size 450

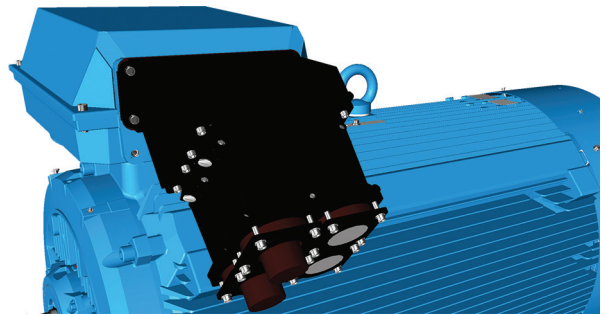

Terminal box for motor sizes 450, with adapter and cable sealing end unit.

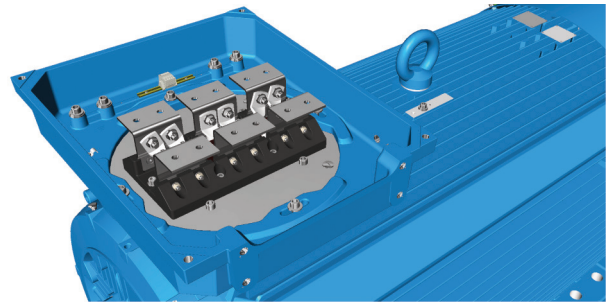

Terminal board for motor size 450.

Terminal box

Terminal box alternatives

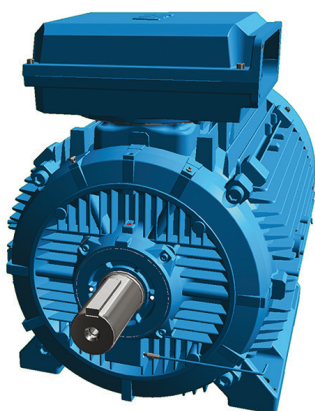

Main terminal box

Optional adapters

There is a broad selection of cable termination accessories available to allow termination of one or several cables. The most common ones are explained below.

How to order?

- Check first that the terminal box itself allows mounting of the desired cable and cores (refer to motor type and terminal box type cross reference on previous page)
- If very large cables are used it might be necessary to use a larger terminal box than standard. Select the right cable gland(s) or cable sealing end unit(s) that match outer diameter of the cable(s)
- Select appropriate adapter or flange
- Note that turning the terminal box to a non-standard position might limit the use of some adapters.

Ordering example

| | |
|-------------------------------------------------------------------------------------------------------------------------|-----------------------------------------------------------------------------------------------------------------------------------------------------------------|
| Motor Cables | 200 kW, 4 pole, 400 V 50 Hz 2 pieces, outer diameter 58 mm, single core cross section 185 mm ² , clamping device needed, cables coming from below |
| | |
| Needed one terminal box for anticondensation heaters and another for temperature detectors, material must be cast iron. | |
| | |
| Motor | M3BP 315 MLA 4-pole, B3 |
| Adapter | D-D - variant code 293 |
| Cable sealing end unit | Variant code 278 |
| Clamping | Variant code 231 |
| Auxiliaries | Variant codes 380, 567, 568 |



Adapters, Flange with glands; cable sealing end units





Main terminal box and maximum single core cross-section

You can select one size larger than standard terminal box if a larger single cross-section is needed. The standard sizes of the main terminal box are listed in the following table. The terminal box is named according to its current-carrying capacity, from 120 to 1200. Check also the capacity of the cable entry to make sure that the cables fit. A larger terminal box can be ordered with variant code 019.

| Standard terminal box | Large terminal box | Size of opening, large box | Max single cross-section mm ² /phase |
|-----------------------|--------------------|----------------------------|-------------------------------------------------|
| 120 | 210 | B | 1 x 70 |
| 210 | 370 | C | 2 x 240 |
| 370 | 750 | D | 2 x 300 |
| 750 | 1200 | E | 4 x 500 |
| 1200 | - | - | - |

Optional adapters

To allow easy termination of cables entering the terminal box from above or below, an angle adapter is recommended. These are available for motor sizes 280 and above and can also be used to allow the mounting of several cable sealing end units or gland plates. For exact suitability on a certain motor size, refer to the 'terminal box opening' column in section Standard terminal box.

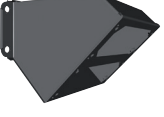
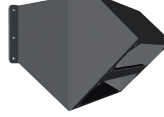
| Adapter |  |  |  |  |  |  |
|--------------------------------|-----------------------------------------------------------------------------------|-----------------------------------------------------------------------------------|-----------------------------------------------------------------------------------|------------------------------------------------------------------------------------|-------------------------------------------------------------------------------------|-------------------------------------------------------------------------------------|
| Variant code | 292 | 293 | 294 | 295 | 296 | 444 |
| Suited for motor sizes | 280 | 315, 355 | 315 LKC IE2, 355 SM_ 2-4 poles, 400 - 450 | 315 LKC IE2, 355 SM_ 2-4 poles, 400 - 450 | 315 LKC IE2, 355 SM_ 2-4 poles, 400 - 450 | 315 LKC IE2, 355 SM_ 2-4 poles, 400 - 450 |
| Opening to terminal box | C | D | E | E | E | E |
| Flange or opening for end unit | C | D | D | 2 x D | 3 x D | 2 x E |
| Material | Steel | Steel | Steel | Steel | Steel | Steel |
| Notes | | | Included in type 750 terminal box when 750 is the standard size. | Included in type 1200 terminal box when 1200 is the standard size. | Only possible on type 1200 terminal box | Only possible on type 1200 terminal box |

Cable sealing end units

As an alternative to flanges and cable glands, cable sealing end units can be used. These allow more space for spreading the cores for easy termination.

Cable sealing end units have rubber-sealed entries for one of two main cables. In addition, there are two plugged M20 holes for auxiliary cables.

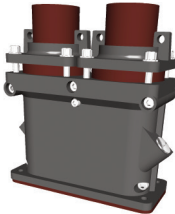
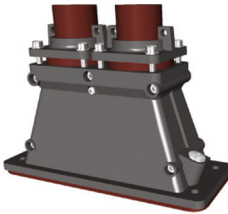
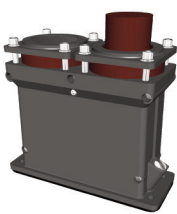
| End unit | Small | Medium | Large |
|---------------------------------|-------------------------------------------------------------------------------------|--------------------------------------------------------------------------------------|---------------------------------------------------------------------------------------|
| |  |  |  |
| Variant code | 277 | 278 | 279 |
| Suited for motor sizes | 280 | 315, 355, except 315 LKC IE2, 355 SM_ 2-4 poles | 315, 355, except 315 LKC IE2, 355 SM_ 2-4 poles |
| Opening to terminal box | C | D | D |
| Cable outer diameter | 1 - 2 cables, 48 - 60 mm | 1 - 2 cables, 48 - 60 mm | 1 - 2 cables, 60 - 80 mm |
| Cable entry for auxiliary cable | 2 x M20 plugged holes | 2 x M20 plugged holes | 2 x M20 plugged holes |
| Additional optional variants | EMC cable gland (704); Standard gland with clamping device (231) | EMC cable gland (704); Standard gland with clamping device (231) | EMC cable gland (704); Standard gland with clamping device (231) |

Auxiliary terminal box

You can equip motors from frame size 160 upward with one or several auxiliary terminal boxes for connection of auxiliaries like heaters or temperature detectors. The standard auxiliary terminal box material for motor sizes 280 - 450 is aluminum and for 160 - 250 cast iron. For 280 - 450, cast iron as box material is also available as an option.

Connection terminals are of spring-loaded type for quick and easy connection. These are suitable for up to 2.5 mm² wires. Auxiliary terminal boxes for 280 - 450 are equipped with an earthing terminal. The first auxiliary terminal box is located on the right-hand side at D-end as standard.

The standard cable entry size is M20 for the aluminum box and M16 for the cast iron box, and the number of entries depends on the terminal box type and the number of selected auxiliaries

Related variant codes

| | |
|-----|--------------------------------------------------------------------|
| 380 | Separate terminal box for temperature detectors, standard material |
| 418 | Separate terminal box for auxiliaries, standard material |
| 567 | Separate terminal box material: cast iron |
| 568 | Separate terminal box for heating elements, standard material |
| 569 | Separate terminal box for brake |

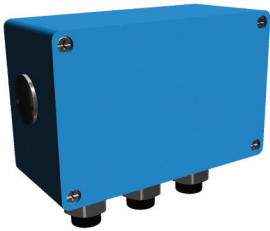

Small auxiliary aluminum terminal box for motor sizes 280 - 450 (variant codes 418, 568, 380, 569)
The size of terminal box ordered with these codes depends on the number of accessories ordered.
80 x 125 mm, max 12 strips. Earthing size M4

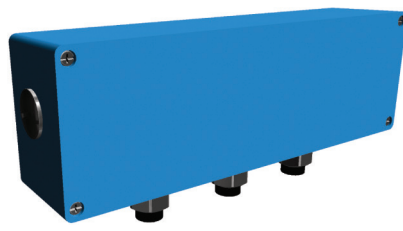

Large auxiliary aluminum terminal box for motor sizes 280 - 450.
The size of terminal box ordered with these codes depends on the number of accessories ordered.
80 x 250 mm, max 30 strips. Earthing size M4

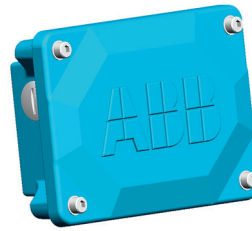

Auxiliary cast iron terminal box
Frame size for motor sizes 160 - 250 (variant code 418):
111 x 162 mm, max. 18 strips. No earthing.

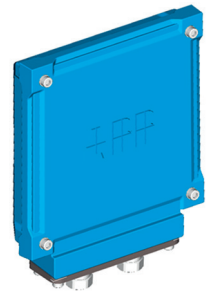

Frame size for motor sizes 280 - 450 (variant code 567):
208 x 180 mm, max 30 strips. Earthing size M6

Dimension drawings

Foot-mounted cast iron motors, 71 - 132

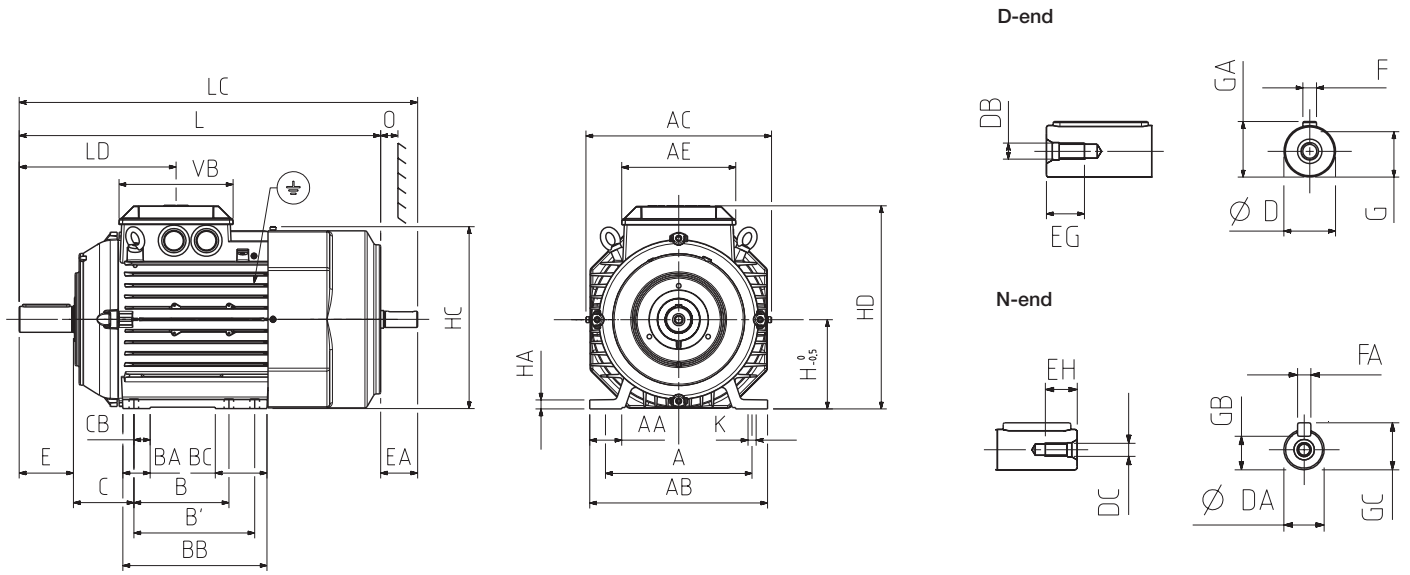

Mounting options IM B3 (IM 1001), IM B6 (IM 1051), IM B7 (IM 1061), IM B8 (IM 1071), IM V5 (IM 1011), IM V6 (IM 1031)

| Motor size | A | AA | AB | AC | AE | B | B' | BA | BB | BC | C | CB | D-Tol. | DA | DB | DC | E |
|---------------------|-----|----|-----|-----|-----|-----|-----|----|-----|----|----|----|--------|----|-----|----|----|
| 71 M ₋ | 112 | 24 | 136 | 139 | 105 | 90 | - | 24 | 110 | 24 | 45 | 10 | 14-j6 | 11 | M5 | M4 | 30 |
| 71 ML ₋ | 112 | 24 | 136 | 139 | 105 | 90 | - | 24 | 110 | 24 | 45 | 10 | 14-j6 | 11 | M5 | M4 | 30 |
| 80 M ₋ | 125 | 28 | 154 | 157 | 105 | 100 | - | 28 | 124 | 28 | 50 | 12 | 19-j6 | 14 | M6 | M5 | 40 |
| 80 ML ₋ | 125 | 28 | 154 | 157 | 105 | 100 | 112 | 28 | 136 | 40 | 50 | 12 | 19-j6 | 14 | M6 | M5 | 40 |
| 90 SL ₋ | 140 | 30 | 170 | 177 | 118 | 100 | 125 | 28 | 150 | 54 | 56 | 12 | 24-j6 | 14 | M8 | M5 | 50 |
| 90 L ₋ | 140 | 30 | 170 | 177 | 118 | 100 | 125 | 28 | 150 | 54 | 56 | 12 | 24-j6 | 14 | M8 | M5 | 50 |
| 100 L ₋ | 160 | 38 | 200 | 197 | 118 | 140 | - | 34 | 172 | 34 | 63 | 16 | 28-j6 | 19 | M10 | M6 | 60 |
| 100 ML ₋ | 160 | 38 | 200 | 197 | 118 | 140 | - | 34 | 172 | 34 | 63 | 16 | 28-j6 | 19 | M10 | M6 | 60 |
| 100 LK ₋ | 160 | 38 | 200 | 197 | 118 | 140 | 160 | 34 | 192 | 54 | 63 | 16 | 28-j6 | 19 | M10 | M6 | 60 |
| IE2 112 | 190 | 41 | 230 | 197 | 110 | 140 | - | 34 | 172 | 34 | 70 | 16 | 28-j6 | 19 | M10 | M6 | 60 |
| IE3 112 | 190 | 41 | 230 | 239 | 168 | 140 | - | 34 | 170 | 34 | 70 | 14 | 28-j6 | 19 | M10 | M6 | 60 |
| 132 | 216 | 47 | 262 | 273 | 168 | 140 | 178 | 40 | 212 | 76 | 89 | 16 | 38-k6 | 24 | M12 | M8 | 80 |

| Motor size | EA | EG | EH | F | FA | G | GA | GB | GC | H | HA | HC | HD | K | L | LD | O | VB |
|---------------------|----|------|------|----|----|------|------|------|------|-----|----|-----|-----|----|-----|-----|----|-----|
| 71 M ₋ | 23 | 12.5 | 10 | 5 | 4 | 11 | 16 | 8.5 | 12.5 | 71 | 9 | 139 | 178 | 7 | 264 | 112 | 20 | 105 |
| 71 ML ₋ | 23 | 12.5 | 30 | 5 | 4 | 11 | 16 | 8.5 | 12.5 | 71 | 9 | 139 | 178 | 7 | 294 | 112 | 20 | 105 |
| 80 M ₋ | 30 | 16 | 12.5 | 6 | 5 | 15.5 | 21.5 | 11 | 16 | 80 | 10 | 157 | 194 | 10 | 331 | 126 | 20 | 105 |
| 80 ML ₋ | 30 | 16 | 12.5 | 6 | 5 | 15.5 | 21.5 | 11 | 16 | 80 | 10 | 157 | 194 | 10 | 363 | 126 | 20 | 105 |
| 90 SL ₋ | 30 | 19 | 12.5 | 8 | 5 | 20 | 27 | 11 | 16 | 90 | 10 | 178 | 218 | 10 | 356 | 151 | 20 | 118 |
| 90 L ₋ | 30 | 19 | 12.5 | 8 | 5 | 20 | 27 | 11 | 16 | 90 | 10 | 178 | 218 | 10 | 390 | 151 | 20 | 118 |
| 100 L ₋ | 40 | 22 | 16 | 8 | 6 | 24 | 31 | 15.5 | 21.5 | 100 | 12 | 198 | 247 | 12 | 381 | 164 | 25 | 118 |
| 100 ML ₋ | 40 | 22 | 16 | 8 | 6 | 24 | 31 | 15.5 | 21.5 | 100 | 12 | 198 | 247 | 12 | 403 | 164 | 25 | 118 |
| 100 LK ₋ | 40 | 22 | 16 | 8 | 6 | 24 | 31 | 15.5 | 21.5 | 100 | 12 | 198 | 247 | 12 | 435 | 164 | 25 | 118 |
| IE2 112 | 40 | 22 | 16 | 8 | 6 | 24 | 31 | 16 | 22 | 112 | 12 | 197 | 259 | 12 | 403 | 164 | 25 | 168 |
| IE3 112 | 40 | 22 | 16 | 8 | 6 | 24 | 31 | 16 | 22 | 112 | 12 | 223 | 258 | 12 | 442 | 200 | 25 | 168 |
| 132 | 50 | 28 | 19 | 10 | 8 | 33 | 41 | 20 | 27 | 132 | 13 | 268 | 300 | 12 | 532 | 231 | 30 | 168 |

Tolerances

| | |
|-------|---------|
| A, B | ± 0.8 |
| D, DA | ISO j6 |
| F, FA | ISO h9 |
| H | +0 -0.5 |
| N | ISO j6 |
| C, CA | ± 0.8 |

Dimension drawings

Flange- and foot & flange mounted cast iron motors, 71 – 132

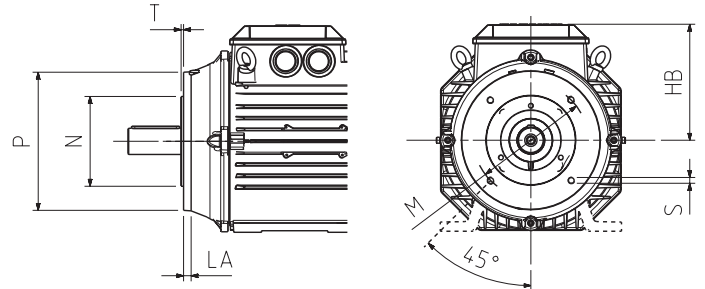
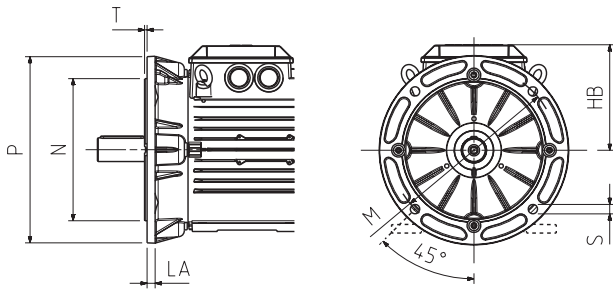

Mounting options IM B5 (IM 3001), V1 (IM 3011), V3 (IM 3031), IM B35 (IM 2001), IM V15 (IM 2011), IM V36 (IM 2031)

Large flange

| Motor size | HB | LA | M | N | P | S | T |
|------------|-----|------|-----|-----|-----|----|-----|
| 71 | 108 | 9 | 130 | 110 | 160 | 10 | 3.5 |
| 80 | 114 | 10 | 165 | 130 | 200 | 12 | 3.5 |
| 90 | 128 | 10 | 165 | 130 | 200 | 12 | 3.5 |
| 100 | 147 | 11 | 215 | 180 | 250 | 15 | 4 |
| IE2 112 | 148 | 11 | 215 | 180 | 250 | 15 | 4 |
| IE3 112 | 146 | 11 | 215 | 180 | 250 | 15 | 4 |
| 132 | 168 | 12.5 | 265 | 230 | 300 | 15 | 4 |

Tolerances

| | |
|-------|---------|
| A, B | ± 0.8 |
| D, DA | ISO j6 |
| F, FA | ISO h9 |
| H | +0 -0.5 |
| N | ISO j6 |
| C, CA | ± 0.8 |

Mounting options IM B14 (IM 3601), V18 (IM 3611), V19 (IM 3631), IM B34 (IM 2101), V17 (IM 2111)

Small flange

| Motor size | HB | LA | M | N | P | S | T |
|------------|-----|----|-----|-----|-----|-----|-----|
| 71 | 108 | 8 | 85 | 70 | 105 | M6 | 2.5 |
| 80 | 114 | 8 | 100 | 80 | 120 | M6 | 3 |
| 90 | 128 | 10 | 115 | 95 | 140 | M8 | 3 |
| 100 | 147 | 10 | 130 | 110 | 160 | M8 | 3.5 |
| IE2 112 | 148 | 10 | 130 | 110 | 160 | M8 | 3.5 |
| IE3 112 | 146 | 14 | 130 | 110 | 160 | M8 | 3.5 |
| 132 | 168 | 12 | 165 | 130 | 200 | M10 | 3.5 |

Dimension drawings

Foot-mounted cast iron motors, 160 - 250

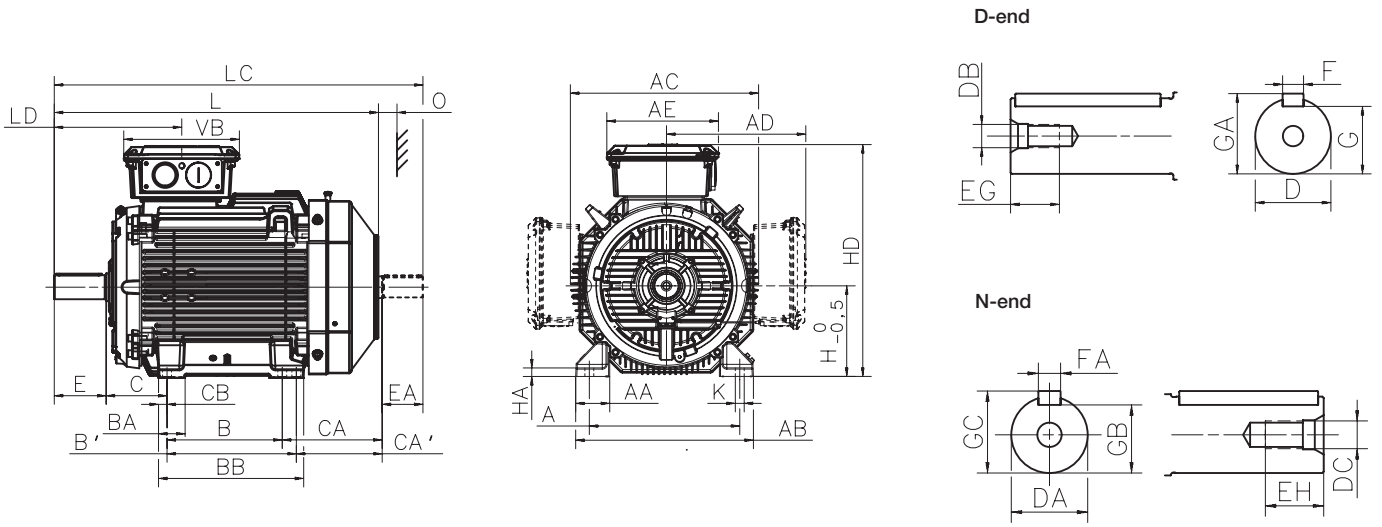

Mounting options IM B3 (IM 1001), IM B6 (IM 1051), IM B7 (IM 1061), IM B8 (IM 1071), IM V5 (IM 1011), IM V6 (IM 1031)

| Motor size | Poles | A | AA | AB | AC | AD | AE | B | B' | BA | BB | C | CA | CA' | CB | D | DA | DB | DC | E |
|-------------------|-------|-----|----|-----|-----|-----|-----|-----|-----|----|-----|-----|-----|-----|----|----|----|-----|-----|-----|
| 160 ¹⁾ | 2-8 | 254 | 67 | 310 | 338 | 261 | 257 | 210 | 254 | 69 | 294 | 108 | 164 | 126 | 20 | 42 | 32 | M16 | M12 | 110 |
| 160 ²⁾ | 2-8 | 254 | 67 | 310 | 338 | 261 | 257 | 210 | 254 | 69 | 294 | 108 | 262 | 224 | 20 | 42 | 32 | M16 | M12 | 110 |
| 180 | 2-8 | 279 | 67 | 340 | 381 | 281 | 257 | 241 | 279 | 68 | 317 | 121 | 263 | 225 | 19 | 48 | 32 | M16 | M12 | 110 |
| 200 | 2-8 | 318 | 69 | 378 | 413 | 328 | 300 | 267 | 305 | 80 | 345 | 133 | 314 | 276 | 20 | 55 | 45 | M20 | M16 | 110 |
| 225 | 2 | 356 | 84 | 435 | 460 | 348 | 300 | 286 | 311 | 69 | 351 | 149 | 314 | 289 | 20 | 55 | 55 | M20 | M20 | 110 |
| 225 | 4-8 | 356 | 84 | 435 | 460 | 348 | 300 | 286 | 311 | 69 | 351 | 149 | 314 | 289 | 20 | 60 | 55 | M20 | M20 | 140 |
| 250 | 2 | 406 | 92 | 480 | 508 | 376 | 300 | 311 | 349 | 69 | 392 | 168 | 281 | 243 | 23 | 60 | 55 | M20 | M20 | 140 |
| 250 | 4-8 | 406 | 92 | 480 | 508 | 376 | 300 | 311 | 349 | 69 | 392 | 168 | 281 | 243 | 23 | 65 | 55 | M20 | M20 | 140 |

| Motor size | Poles | EA | EG | EH | F | FA | G | GA | GB | GC | H | HA | HD | K | L | LC | LD | O | VB |
|-------------------|-------|-----|----|----|----|----|------|------|------|------|-----|----|-----|------|-----|-------|-------|----|-----|
| 160 ¹⁾ | 2-8 | 80 | 36 | 28 | 12 | 10 | 37 | 45 | 27 | 35 | 160 | 23 | 421 | 14.5 | 584 | 671.5 | 287.5 | 45 | 257 |
| 160 ²⁾ | 2-8 | 80 | 36 | 28 | 12 | 10 | 37 | 45 | 27 | 35 | 160 | 23 | 421 | 14.5 | 681 | 768.5 | 287.5 | 45 | 257 |
| 180 | 2-8 | 80 | 36 | 28 | 14 | 10 | 42.5 | 51.5 | 27 | 35 | 180 | 23 | 461 | 14.5 | 726 | 815 | 300.5 | 50 | 257 |
| 200 | 2-8 | 110 | 42 | 36 | 16 | 14 | 49 | 59 | 39.5 | 48.5 | 200 | 23 | 528 | 18.5 | 821 | 934 | 320.5 | 70 | 311 |
| 225 | 2 | 110 | 42 | 42 | 16 | 16 | 49 | 59 | 49 | 59 | 225 | 23 | 573 | 18.5 | 849 | 971 | 313.5 | 80 | 311 |
| 225 | 4-8 | 110 | 42 | 42 | 18 | 16 | 53 | 64 | 49 | 59 | 225 | 23 | 573 | 18.5 | 879 | 1001 | 343.5 | 80 | 311 |
| 250 | 2 | 110 | 42 | 42 | 18 | 16 | 53 | 64 | 49 | 59 | 250 | 23 | 626 | 24.0 | 884 | 1010 | 343.5 | 90 | 311 |
| 250 | 4-8 | 110 | 42 | 42 | 18 | 16 | 58 | 69 | 49 | 59 | 250 | 23 | 626 | 24.0 | 884 | 1010 | 343.5 | 90 | 311 |

Tolerances

| | |
|-------|--------------------------------------|
| A, B | ISO js14 |
| C, CA | ± 0.8 |
| D, DA | ISO k6 < Ø 50 mm ISO m6 > Ø 50 mm |
| F, FA | ISO h9 |
| H | +0 -0.5 |

Footnotes

| |
|-------------------------------------------------|
| M3BP IE2: |
| ¹⁾ MLA, MLB 2 and 8 |
| ²⁾ MLB 4-6, MLC 4-8, MLD, MLE, MLC 2 |
| M3BP IE3: |
| ¹⁾ MLA 2 only |
| ²⁾ All others |

Dimension drawings

Flange- and foot & flange mounted cast iron motors, 160 - 250

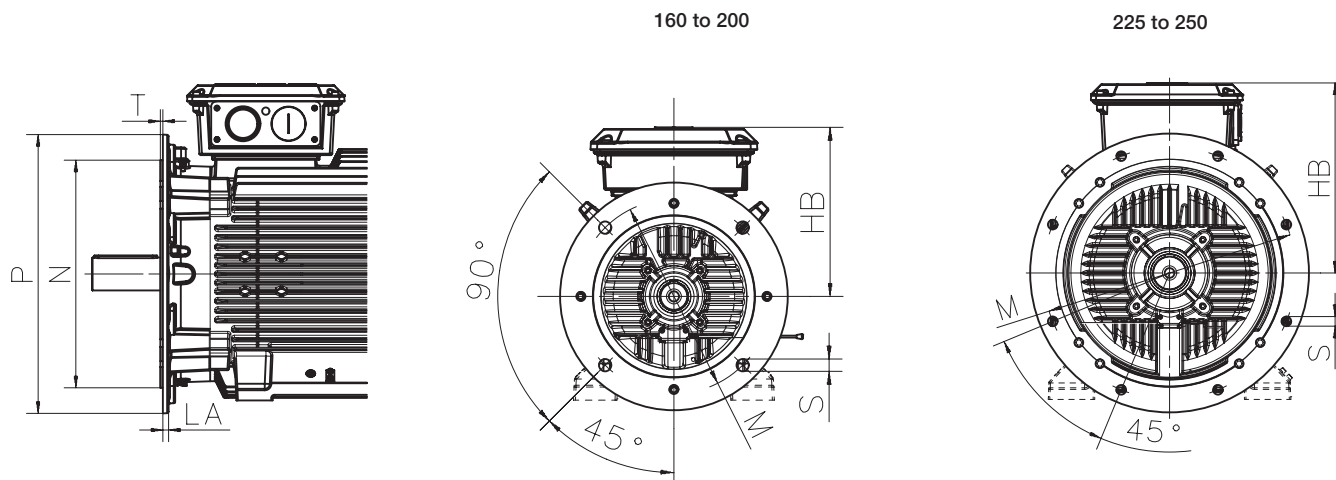

Mounting options IM B5 (IM 3001), V1 (IM 3011), V3 (IM 3031), IM B35 (IM 2001), IM V15 (IM 2011), IM V36 (IM 2031)

| Motor size | Poles | HB | LA | M | N | P | S | T |
|-------------------|-------|-----|----|-----|-----|-----|----|---|
| 160 ¹⁾ | 2-8 | 261 | 20 | 300 | 250 | 350 | 19 | 5 |
| 160 ²⁾ | 2-8 | 261 | 20 | 300 | 250 | 350 | 19 | 5 |
| 180 | 2-8 | 281 | 15 | 300 | 250 | 350 | 19 | 5 |
| 200 | 2-8 | 328 | 20 | 350 | 300 | 400 | 19 | 5 |
| 225 | 2 | 348 | 20 | 400 | 350 | 450 | 19 | 5 |
| 225 | 4-8 | 325 | 20 | 400 | 350 | 450 | 19 | 5 |
| 250 | 2 | 376 | 24 | 500 | 450 | 550 | 19 | 5 |
| 250 | 4-8 | 376 | 24 | 500 | 450 | 550 | 19 | 5 |

Tolerances

| | |
|-------|------------------|
| A, B | ISO js14 |
| C, CA | ± 0.8 |
| D, DA | ISO k6 < Ø 50 mm |
| | ISO m6 > Ø 50 mm |
| F, FA | ISO h9 |
| H | +0 -0.5 |
| N | ISO j6 |

Footnotes

| |
|-------------------------------------------------|
| M3BP IE2: |
| ¹⁾ MLA, MLB 2 and 8 |
| ²⁾ MLB 4-6, MLC 4-8, MLD, MLE, MLC 2 |
| M3BP IE3: |
| ¹⁾ MLA 2 only |
| ²⁾ All others |

Dimension drawings

Foot-mounted cast iron motors, 280 - 315

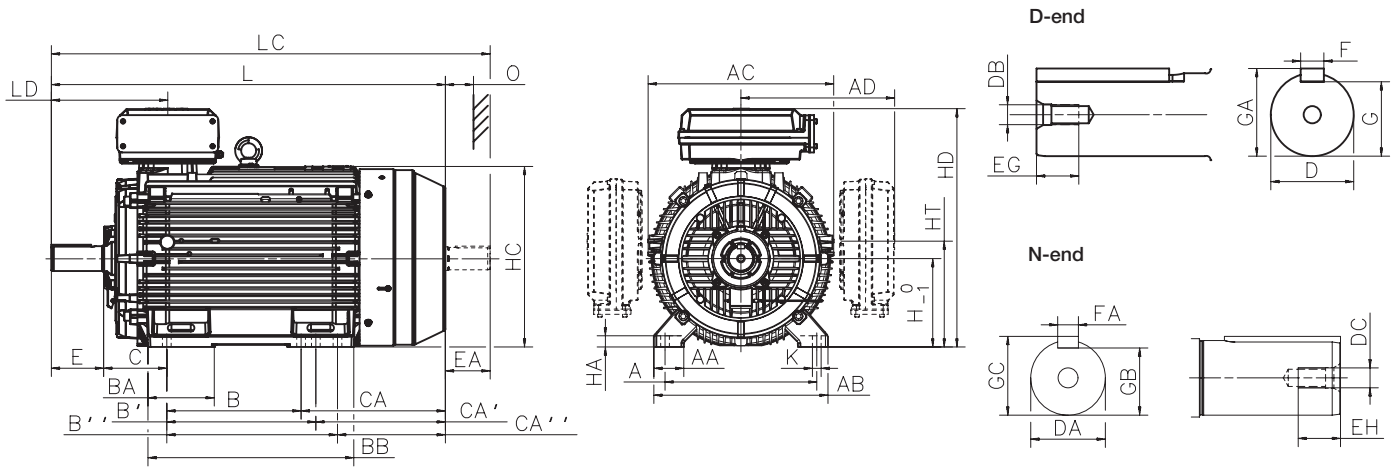

Mounting options IM B3 (IM 1001), IM B6 (IM 1051), IM B7 (IM 1061), IM B8 (IM 1071), IM V5 (IM 1011), IM V6 (IM 1031)

| Motor size | Poles | A | AA | AB | AC | AD ¹⁾ | AD ²⁾ | B | B' | B'' | BA | BB | C | CA | CA' | CA'' | D | DA | DB | DC | E |
|---------------------|-------|-----|-----|-----|-----|------------------|------------------|-----|-----|-----|-----|-----|-----|-----|-----|------|----|----|-----|-----|-----|
| 280 SM _L | 2 | 457 | 84 | 530 | 577 | 481 | - | 368 | 419 | - | 147 | 506 | 190 | 400 | 349 | - | 65 | 60 | M20 | M20 | 140 |
| | 4-12 | 457 | 84 | 530 | 577 | 481 | - | 368 | 419 | - | 147 | 506 | 190 | 400 | 349 | - | 75 | 65 | M20 | M20 | 140 |
| 280 ML _L | 2 | 457 | 84 | 530 | 577 | - | 504 | 419 | 457 | - | 193 | 608 | 190 | 400 | 349 | - | 65 | 60 | M20 | M20 | 140 |
| | 4-12 | 457 | 84 | 530 | 577 | 481 | 504 | 419 | 457 | - | 193 | 608 | 190 | 400 | 349 | - | 75 | 65 | M20 | M20 | 140 |
| 315 SM _L | 2 | 508 | 100 | 590 | 654 | 545 | - | 406 | 457 | - | 180 | 558 | 216 | 420 | 369 | - | 65 | 60 | M20 | M20 | 140 |
| | 4-12 | 508 | 100 | 590 | 654 | 545 | - | 406 | 457 | - | 180 | 558 | 216 | 420 | 369 | - | 80 | 75 | M20 | M20 | 170 |
| 315 ML _L | 2 | 508 | 100 | 590 | 654 | 545 | - | 457 | 508 | - | 212 | 669 | 216 | 480 | 429 | - | 65 | 60 | M20 | M20 | 140 |
| | 4-12 | 508 | 100 | 590 | 654 | 545 | - | 457 | 508 | - | 212 | 669 | 216 | 480 | 429 | - | 90 | 75 | M24 | M20 | 170 |
| 315 LK _L | 2 | 508 | 100 | 590 | 654 | 562 | 576 | 508 | 560 | 710 | 336 | 851 | 216 | 635 | 583 | 433 | 65 | 60 | M20 | M20 | 140 |
| | 4-12 | 508 | 100 | 590 | 654 | 562 | 576 | 508 | 560 | 710 | 336 | 851 | 216 | 635 | 583 | 433 | 90 | 75 | M24 | M20 | 170 |

| Motor size | Poles | EA | EG | EH | F | FA | G | GA | GB | GC | H | HA | HC | HD ¹⁾ | HD ²⁾ | HT | K | L | LC | LD | LD top-m. | LD side-m. | O |
|---------------------|-------|-----|----|----|----|----|------|------|------|------|-----|----|-----|------------------|------------------|-------|----|------|------|-----|-----------|------------|---|
| 280 SM _L | 2 | 140 | 40 | 40 | 18 | 18 | 58 | 69 | 53 | 64 | 280 | 31 | 564 | 762 | - | 337.5 | 24 | 1088 | 1238 | 336 | 539 | 100 | |
| | 4-12 | 140 | 40 | 40 | 20 | 18 | 67.5 | 79.5 | 58 | 69 | 280 | 31 | 564 | 762 | - | 337.5 | 24 | 1088 | 1238 | 336 | 539 | 100 | |
| 280 ML _L | 2 | 140 | 40 | 40 | 18 | 18 | 58 | 69 | 53 | 64 | 280 | 31 | 564 | - | 785 | 337.5 | 24 | 1189 | 1340 | 336 | 590 | 100 | |
| | 4-12 | 140 | 40 | 40 | 20 | 18 | 67.5 | 79.5 | 58 | 69 | 280 | 31 | 564 | 762 | 785 | 337.5 | 24 | 1189 | 1340 | 336 | 590 | 100 | |
| 315 SM _L | 2 | 140 | 40 | 40 | 18 | 18 | 58 | 69 | 53 | 64 | 315 | 40 | 638 | 852 | - | 375 | 28 | 1174 | 1322 | 356 | 585 | 115 | |
| | 4-12 | 140 | 40 | 40 | 22 | 20 | 71 | 85 | 67.5 | 79.5 | 315 | 40 | 638 | 852 | - | 375 | 28 | 1204 | 1352 | 386 | 615 | 115 | |
| 315 ML _L | 2 | 140 | 40 | 40 | 18 | 18 | 58 | 69 | 53 | 64 | 315 | 40 | 638 | 852 | - | 375 | 28 | 1285 | 1433 | 356 | 640 | 115 | |
| | 4-12 | 140 | 48 | 40 | 25 | 20 | 81 | 95 | 67.5 | 79.5 | 315 | 40 | 638 | 852 | - | 375 | 28 | 1315 | 1463 | 386 | 670 | 115 | |
| 315 LK _L | 2 | 140 | 40 | 40 | 18 | 18 | 58 | 69 | 53 | 64 | 315 | 40 | 638 | 852 | 880 | 359 | 28 | 1491 | 1639 | 356 | 721 | 115 | |
| | 4-12 | 140 | 48 | 40 | 25 | 20 | 81 | 95 | 67.5 | 79.5 | 315 | 40 | 638 | 852 | 880 | 359 | 28 | 1521 | 1669 | 386 | 751 | 115 | |

Tolerances

| | |
|-------|--------------------------------------|
| A, B | ± 0.8 |
| C, CA | ± 0.8 |
| D | ISO k6 < Ø 50 mm ISO m6 > Ø 50 mm |
| F | ISO h9 |
| H | + 0 -0.5 |
| N | ISO j6 |

Footnotes

- ¹⁾ Terminal box 370
²⁾ Terminal box 750

Dimension drawings

Flange- and foot & flange mounted cast iron motors, 280 - 315

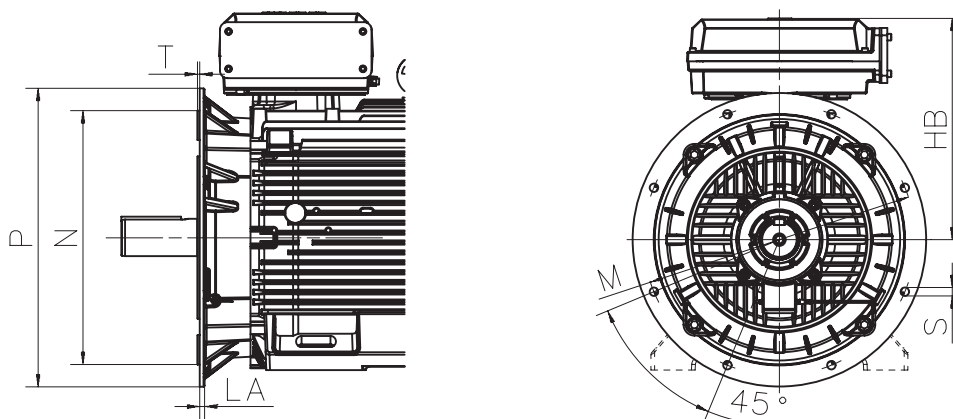

Mounting options IM B5 (IM 3001)V1, (IM 3011), V3 (IM 3031), IM B35 (IM 2001), IM V15 (IM 2011), IM V36 (IM 2031)

| Motor size | Poles | HB ¹⁾ | HB ²⁾ | LA | M | N | P | S | T |
|---------------------|-------|------------------|------------------|----|-----|-----|-----|----|---|
| 280 SM ₋ | 2 | 482 | - | 23 | 500 | 450 | 550 | 18 | 5 |
| | 4-12 | 482 | - | 23 | 500 | 450 | 550 | 18 | 5 |
| 280 ML ₋ | 2 | - | 505 | 23 | 500 | 450 | 550 | 18 | 5 |
| | 4-12 | 482 | 505 | 23 | 500 | 450 | 550 | 15 | 5 |
| 315 SM ₋ | 2 | 537 | - | 25 | 600 | 550 | 660 | 23 | 6 |
| | 4-12 | 537 | - | 25 | 600 | 550 | 660 | 23 | 6 |
| 315 ML ₋ | 2 | 537 | - | 25 | 600 | 550 | 660 | 23 | 6 |
| | 4-12 | 537 | - | 25 | 600 | 550 | 660 | 23 | 6 |
| 315 LK ₋ | 2 | 537 | 565 | 25 | 600 | 550 | 660 | 23 | 6 |
| | 4-12 | 537 | 565 | 25 | 600 | 550 | 660 | 23 | 6 |

Tolerances

| | |
|------|-------------------------------|
| A, B | ± 0.8 |
| D | ISO j6 |
| F | ISO h9 |
| H | +0 - 0.1 |
| N | ISO j6 (280 SM ₋) |
| | ISO js6 (315 ₋) |
| C | ± 0.8 |

Footnotes

- ¹⁾ Terminal box 370
²⁾ Terminal box 750

Dimension drawings

Foot-mounted cast iron motors, 355 - 450

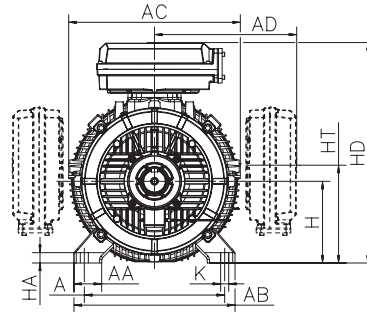
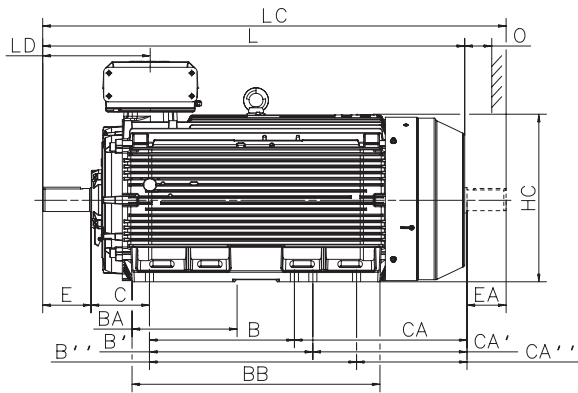

D-end

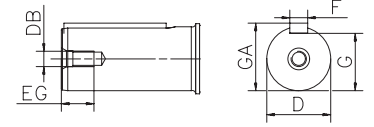

N-end

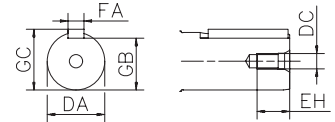

Mounting options IM B3 (IM 1001), IM B6 (IM 1051), IM B7 (IM 1061), IM B8 (IM 1071), IM V5 (IM 1011), IM V6 (IM 1031)

| Motor size | Poles | A | AA | AB | AC | AD ¹⁾ | AD ²⁾ | B | B' | B'' | BA | BB | C | CA | CA' | CA'' | D | DA | DB | DC | E | EA | EG | EH |
|-----------------------------------|-------|-----|-----|-----|-----|------------------|------------------|------|------|------|-----|------|-----|-----|-----|------|-----|-----|-----|-----|-----|-----|----|----|
| 355 SM _L | 2 | 610 | 120 | 700 | 746 | 604 | 618 | 500 | 560 | - | 221 | 722 | 254 | 525 | 465 | - | 70 | 70 | M20 | M20 | 140 | 140 | 42 | 40 |
| | 4-12 | 610 | 120 | 700 | 746 | 604 | 618 | 500 | 560 | - | 221 | 722 | 254 | 525 | 465 | - | 100 | 90 | M24 | M24 | 210 | 170 | 51 | 48 |
| 355 ML _L | 2 | 610 | 120 | 700 | 746 | 604 | 618 | 560 | 630 | - | 267 | 827 | 254 | 500 | 570 | - | 70 | 70 | M20 | M20 | 140 | 140 | 42 | 40 |
| | 4-12 | 610 | 120 | 700 | 746 | 604 | 618 | 560 | 630 | - | 267 | 827 | 254 | 500 | 570 | - | 100 | 90 | M24 | M24 | 210 | 170 | 51 | 48 |
| 355 LK _L | 2 | 610 | 120 | 700 | 746 | 604 | 618 | 630 | 710 | 900 | 447 | 1077 | 254 | 750 | 670 | 480 | 70 | 70 | M20 | M20 | 140 | 140 | 42 | 40 |
| | 4-12 | 610 | 120 | 700 | 746 | 604 | 618 | 630 | 710 | 900 | 447 | 1077 | 254 | 750 | 670 | 480 | 100 | 90 | M24 | M24 | 210 | 170 | 51 | 48 |
| 400 L _L | 2 | 710 | 150 | 840 | 834 | - | 660 | 900 | 1000 | - | 410 | 1156 | 224 | 567 | 467 | - | 80 | 70 | M20 | M20 | 170 | 140 | 42 | 40 |
| | 4-12 | 710 | 150 | 840 | 834 | - | 660 | 900 | 1000 | - | 410 | 1156 | 224 | 567 | 467 | - | 110 | 90 | M24 | M24 | 210 | 170 | 50 | 50 |
| 400 LK _L ⁵⁾ | 2 | 686 | 150 | 840 | 834 | - | 660 | 710 | 800 | 900 | 410 | 1156 | 280 | 701 | 611 | 511 | 80 | 70 | M20 | M20 | 170 | 140 | 42 | 40 |
| | 4-12 | 686 | 150 | 840 | 834 | - | 660 | 710 | 800 | 900 | 410 | 1156 | 280 | 701 | 611 | 511 | 100 | 90 | M24 | M24 | 210 | 170 | 50 | 50 |
| 450 | 2 | 800 | 160 | 950 | 966 | - | - | 1000 | 1120 | 1250 | 450 | 1420 | 250 | - | - | - | 80 | - | M20 | - | 170 | - | - | - |
| | 4-12 | 800 | 160 | 950 | 966 | - | - | 1000 | 1120 | 1250 | 450 | 1420 | 250 | 737 | 617 | 487 | 120 | 100 | M24 | M24 | 210 | 210 | 50 | 50 |

| Motor size | Poles | F | FA | G | GA | GB | GC | H | HA | HC | HD ¹⁾ | HD ²⁾ | HD ³⁾ | HD ⁴⁾ | HT | K | L | LC | LD ¹⁾ | LD ²⁾ | LD ³⁾ | LD ⁴⁾ | O | |
|-----------------------------------|-------|----|----|------|------|------|------|-----|----|-----|------------------|------------------|------------------|------------------|-----|----|------|------|------------------|------------------|------------------|------------------|-----|-----|
| | | | | | | | | | | | | top- | top- | side-m. | | | | | | | | | | |
| 355 SM _L | 2 | 20 | 20 | 62.5 | 74.5 | 62.5 | 74.5 | 355 | 45 | 725 | 944 | 958 | - | 843 | 425 | 35 | 1409 | 1559 | 397 | 397 | - | - | 679 | 130 |
| | 4-12 | 28 | 25 | 90 | 106 | 81 | 95 | 355 | 45 | 725 | 944 | 958 | - | 843 | 425 | 35 | 1479 | 1659 | 467 | 467 | - | - | 750 | 130 |
| 355 ML _L | 2 | 20 | 20 | 62.5 | 74.5 | 62.5 | 74.5 | 355 | 45 | 725 | 944 | 958 | - | 843 | 425 | 35 | 1514 | 1664 | 397 | 397 | - | - | 732 | 130 |
| | 4-12 | 28 | 25 | 90 | 106 | 81 | 95 | 355 | 45 | 725 | 944 | 958 | - | 843 | 425 | 35 | 1584 | 1764 | 467 | 467 | - | - | 802 | 130 |
| 355 LK _L | 2 | 20 | 20 | 62.5 | 74.5 | 62.5 | 74.5 | 355 | 45 | 725 | 944 | 958 | - | 843 | 425 | 35 | 1764 | 1914 | 397 | 397 | - | - | 857 | 130 |
| | 4-12 | 28 | 25 | 90 | 106 | 81 | 95 | 355 | 45 | 725 | 944 | 958 | - | 843 | 425 | 35 | 1834 | 2014 | 467 | 467 | - | - | 927 | 130 |
| 400 L _L | 2 | 22 | 20 | 71 | 85 | 67.5 | 79.5 | 400 | 45 | 814 | - | 1045 | - | 943 | 477 | 35 | 1851 | 2001 | 458 | 458 | - | - | 909 | 150 |
| | 4-12 | 28 | 25 | 100 | 116 | 81 | 95 | 400 | 45 | 814 | - | 1045 | - | 943 | 477 | 35 | 1891 | 2071 | 498 | 498 | - | - | 949 | 150 |
| 400 LK _L ⁵⁾ | 2 | 22 | 20 | 71 | 85 | 67.5 | 79.5 | 400 | 45 | 814 | - | 1045 | - | 943 | 477 | 35 | 1851 | 2001 | 458 | 458 | - | - | 909 | 150 |
| | 4-12 | 28 | 25 | 90 | 106 | 81 | 95 | 400 | 45 | 814 | - | 1045 | - | 943 | 477 | 35 | 1891 | 2071 | 498 | 498 | - | - | 949 | 150 |
| 450 | 2 | 22 | - | 71 | 85 | - | - | 450 | 46 | 933 | - | 1169 | 1293 | - | - | 42 | 2147 | - | - | 485 | 520 | - | - | 180 |
| | 4-12 | 32 | 28 | 109 | 127 | 100 | 116 | 450 | 46 | 933 | - | 1169 | 1293 | - | - | 42 | 2187 | 2407 | - | 525 | 560 | - | - | 180 |

Tolerances

| | |
|-------|---------|
| A, B | ± 0.8 |
| D, DA | ISO m6 |
| F, FA | ISO h9 |
| H | +0 -0.1 |
| N | ISO j6 |
| C, CA | ± 0.8 |

Footnotes

- ¹⁾ Terminal box 370
- ²⁾ Terminal box 750
- ³⁾ Terminal box 1200
- ⁴⁾ Lifting lugs included
- ⁵⁾ Same electrical values as with 400 L_L, alternative dimensions.

Dimension drawings

Flange- and foot & flange mounted cast iron motors, 355 - 450

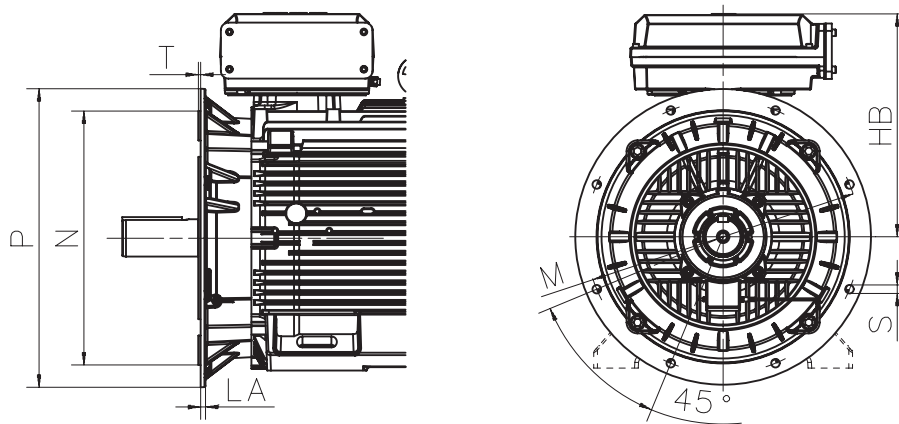

Bottom view

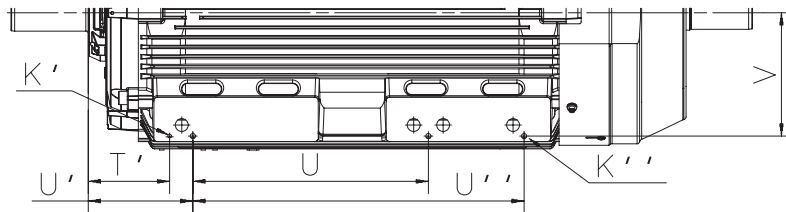

Mounting options IM B5 (IM 3001), V1 (IM 3011), V3 (IM 3031), IM B35 (IM 2001), IM V15 (IM 2011), IM V36 (IM 2031)

Flange

| Motor size | Poles | HB ¹⁾ | HB ²⁾ | HB ³⁾ | LA | M | N | P | S | T |
|-----------------------------------|-------|------------------|------------------|------------------|----|------|------|------|----|---|
| 355 SM ₋ | 2 | 589 | 603 | - | 25 | 740 | 680 | 800 | 23 | 6 |
| | 4-12 | 589 | 603 | - | 25 | 740 | 680 | 800 | 23 | 6 |
| 355 ML ₋ | 2 | 589 | 603 | - | 25 | 740 | 680 | 800 | 23 | 6 |
| | 4-12 | 589 | 603 | - | 25 | 740 | 680 | 800 | 23 | 6 |
| 355 LK ₋ | 2 | 589 | 603 | - | 25 | 740 | 680 | 800 | 23 | 6 |
| | 4-12 | 589 | 603 | - | 25 | 740 | 680 | 800 | 23 | 6 |
| 400 L ₋ | 2 | - | 645 | - | 26 | 940 | 880 | 1000 | 28 | 6 |
| | 4-12 | - | 645 | - | 26 | 940 | 880 | 1000 | 28 | 6 |
| 400 LK ₋ ⁴⁾ | 2 | - | 645 | - | 26 | 740 | 680 | 800 | 24 | 6 |
| | 4-12 | - | 645 | - | 26 | 740 | 680 | 800 | 24 | 6 |
| 450 | 2 | - | 719 | 843 | 33 | 1080 | 1000 | 1150 | 28 | 6 |
| | 4-12 | - | 719 | 843 | 33 | 1080 | 1000 | 1150 | 28 | 6 |

Bottom

| Motor size | Poles | K' | K'' | T' | U | U' | U'' | V |
|-----------------------------------|-------|----|-----|-----|-----|-----|-----|-----|
| 355 SM ₋ | 2 | 10 | M16 | 120 | 280 | 560 | - | 670 |
| | 4-12 | 10 | M16 | 120 | 282 | 560 | - | 670 |
| 355 ML ₋ | 2 | 10 | M16 | 120 | 282 | 630 | - | 670 |
| | 4-12 | 10 | M16 | 120 | 282 | 630 | - | 670 |
| 355 LK ₋ | 2 | 10 | M16 | 120 | 282 | 630 | 890 | 670 |
| | 4-12 | 10 | M16 | 120 | 282 | 630 | 890 | 670 |
| 400 L ₋ | 2 | 10 | M16 | 248 | 287 | 887 | - | 802 |
| | 4-12 | 10 | M16 | 248 | 287 | 887 | - | 802 |
| 400 LK ₋ ⁴⁾ | 2 | 10 | M16 | 248 | 287 | 748 | 916 | 802 |
| | 4-12 | 10 | M16 | 248 | 287 | 748 | 916 | 802 |
| 450 | 2 | 10 | M16 | 274 | 290 | 861 | - | 912 |
| | 4-12 | 10 | M16 | 274 | 323 | 841 | - | 912 |

Tolerances

| | |
|-------|---------|
| A, B | ± 0.8 |
| D, DA | ISO m6 |
| F, FA | ISO h9 |
| H | +0 -1.0 |
| N | ISO js6 |
| C, CA | ± 0.8 |

Footnotes

- ¹⁾ Terminal box 370
- ²⁾ Terminal box 750
- ³⁾ Terminal box 1200
- ⁴⁾ Same electrical values as with 400 L₋, alternative dimensions.

Accessories

Built-in brake (variant code 412)

Brake design

Electromagnetic disc brakes are applied by the action of a set of springs and are released when voltage is applied to the brake coil.

This means that the motor will brake automatically in case of any voltage failure, as significant safety feature. The brake is always functional, irrespective of the mounting position of the brake motor.

Detailed view

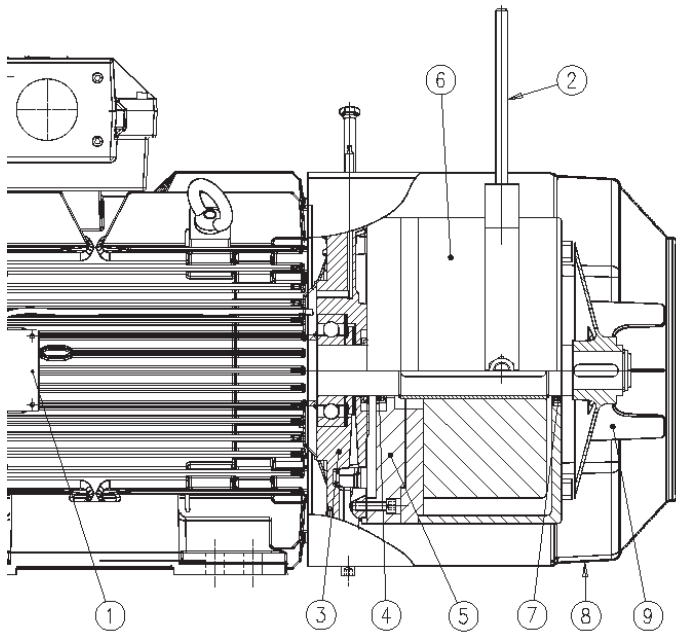

- 1 Connection box, (with rectifier, optional)
- 2 Manual release (optional)
- 3 Modified N-end shield
- 4 V-ring seal
- 5 Adapter flange for brake
- 6 Brake
- 7 V-ring seal
- 8 Fan cover
- 9 Fan

Brake disc

The brake linings are made of asbestos-free material. The linings are highly resistant to wear and have excellent thermal conductivity, providing consistent performance also in high temperatures.

The brake disc withstands a large number of braking instances and is insensitive to dust and moisture.

Note that changing from a used to a new disc will result in a different braking torque.

Replacing the brake disc

The brake disc must be replaced when the minimum permissible lining thickness has been reached. For minimum lining thickness, refer to the brake manufacturer's catalog.

Rectifier

Rectifier is a device for DC brake applications. It is highly resistant to temperature changes as well as to voltage peaks and has additional protection for the auxiliary contact of the contactor. Thanks to its compact design, it can be placed inside the motor's terminal box. Rectifier is an optional element.

Torque adjustment

Reducing the torque of the brake is possible with most brake types. Refer to the brake manufacturer's catalog or contact ABB for more information.

Manual release

Manual release bolts are provided as standard. A manual release handle is an optional element. Manual release overrides the action of brake springs as long as it is applied.

Though the manual release handle is optionally available for all motor sizes, it cannot be used in combination with the Pintsch Bamag brake type SFB.

Brake rating plates

The brake comes with two rating plates, one attached to the brake itself and another delivered loose, together with the motor. Variant code 412 is marked on the motor's rating plate (if it is listed among the five first codes on the motor order).

Available brake types

Motors can be fitted with recommended brakes from either Pintsch Bamag or Stromag, as seen in the tables below. Other brakes can be provided on request.

| Brake type | Brake torque | |
|------------|--------------|----------------|
| | Nm | For motor size |
| KFB 10 | 100 | 160 |
| KFB 16 | 160 | 160 - 180 |
| KFB 25 | 250 | 180 - 225 |
| KFB 40 | 400 | 200 - 250 |
| KFB 63 | 630 | 225 - 280 |
| KFB 1000 | 1000 | 280 - 315 |
| KFB 1600 | 1600 | 315 - 355 |
| On request | | 355 - 450 |

Pintsch & Bamag, type KFB, IP 67, 110 V DC Electromagnetic Double-Disc Spring-Applied Brake

| Brake type | Brake torque | |
|------------|--------------|----------------|
| | Nm | For motor size |
| SFB 16 | 160 | 200 - 225 |
| SFB 25 | 250 | 200 - 225 |
| SFB 40 | 400 | 225 - 250 |
| SFB 63 | 630 | 250 |
| SFB 100 | 1000 | 280 - 315 |
| SFB 160 | 1600 | 315 - 355 |
| SFB 250 | 2500 | 355 - 400 |
| SFB 400 | 4000 | 400 |
| On request | | 450 |

Pintsch & Bamag, type SFB, IP 67, 110 V DC Electromagnetic Double-Disc Spring-Applied Brake

| Brake type | Brake torque | |
|------------------------------|--------------|----------------|
| | Nm | For motor size |
| NFF 10 | 100 | 160 |
| NFF 16 | 160 | 160 - 180 |
| NFF 25 | 250 | 180 - 225 |
| NFF 40 | 400 | 200 - 250 |
| NFF 63 | 630 | 225 - 250 |
| For sizes 280-450 on request | | |

Stromag, type NFF, 110 V DC, IP66

Options for the brake

On new manufacture only

- Hand release (not possible for Pintsch Bamag brake type SFB)
- Rectifier
- Micro switch
- Proximity switch (not possible for Stromag brake)
- Standstill heater

On request

- Special brake voltage
- Raised brake torque
- Combination with brake, separate cooling fan and/or tachometer
- For other variants, please contact ABB

Dimensions of brake motor

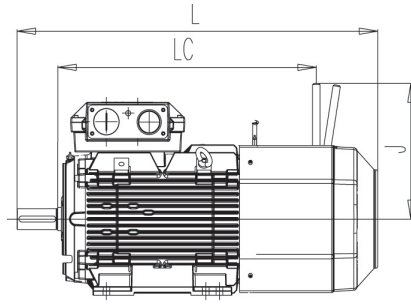

Foot-mounted: IM B3 (IM1001), IM B6 (IM 1051), IM B7 (IM1061), IM B8 (IM 1071), IM V5 (IM 1011), IM V6 (IM 1031)

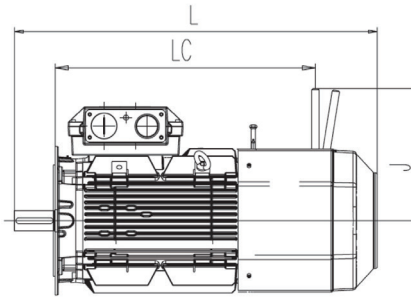

Flange-mounted: IM B5 (IM 3001), IM V1 (IM 3011), IM V3 (IM 3031), IM B14 (IM 3601), IM V18 (IM 3611), IM V19 (IM 3631)

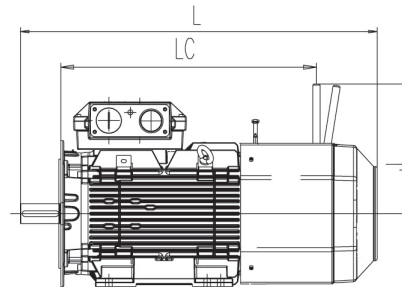

Foot- and flange-mounted: IM B35 (IM 2001), IM V15 (IM 2011), IM V36 (IM 2031)

| Motor size | Poles | Foot-mounted | | | Flange-mounted | | | Foot- and flange-mounted | | |
|-------------------|-------|--------------|-----|-----|----------------|-----|-----|--------------------------|-----|-----|
| | | L | LC | J | L | LC | J | L | LC | J |
| 160 ¹⁾ | 2-8 | 773 | 511 | 372 | 773 | 511 | 372 | 773 | 511 | 372 |
| 160 ²⁾ | 2-8 | 871 | 608 | 372 | 871 | 608 | 372 | 871 | 608 | 372 |
| 180 | 2-8 | 935 | 687 | 372 | 935 | 687 | 372 | 935 | 687 | 372 |
| 200 | 2-8 | 1011 | 695 | 460 | 1011 | 695 | 460 | 1011 | 695 | 460 |
| 225 | 2 | 1085 | 729 | 460 | 1085 | 729 | 460 | 1085 | 729 | 460 |
| 225 | 4-8 | 1115 | 729 | 460 | 1105 | 729 | 460 | 1115 | 729 | 460 |
| 250 | 2-8 | 1119 | 755 | 460 | 1119 | 755 | 460 | 1119 | 755 | 460 |

¹⁾MLA-2, MLB-2, MLC-2, MLA-4, MLA-6, MLA-8 and MLB-8 -poles

²⁾MLD-2, MLE-2, MLB-4, MLC-4, MLD-4, MLB-6, MLC-6 and MLC-8 -poles

Motor sizes 280 to 450 on request. Other dimensions same as Process performance cast iron motors sizes 180 to 250

Accessories

Separate cooling

Axial fan, N-end

Fan motors with an axial fan are available for motor sizes 71-450 and can be ordered with variant code 183.

The values here are given for 400 V, but technical data for other voltages can be found in MotSize.

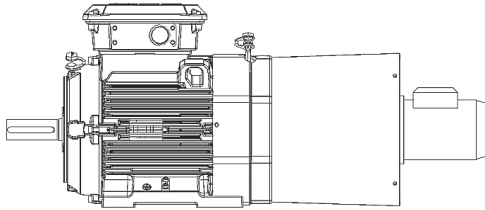

Axial fan, N-end, for motor sizes 71 - 132

| Main motor | Fan motor type | Voltage range at 50 Hz, V | Voltage range at 60 Hz, V | Power W | Current A |
|------------|----------------|---------------------------|---------------------------|---------|-----------|
| M3BP 71 | Wistro 132 | 380 - 500 | 380 - 575 | 29 | 0,06 |
| | | 220 - 290 | 220 - 332 | 28 | 0,1 |
| M3BP 80 | Wistro 156 | 380 - 500 | 380 - 575 | 34 | 0,06 |
| | | 220 - 290 | 220 - 332 | 34 | 0,1 |
| M3BP 90 | Wistro 169 | 380 - 500 | 380 - 575 | 75 | 0,19 |
| | | 220 - 290 | 220 - 332 | 78 | 0,33 |
| M3BP 100 | Wistro 187 | 380 - 500 | 380 - 575 | 94 | 0,17 |
| | | 220 - 290 | 220 - 332 | 87 | 0,31 |
| M3BP 112 | Wistro 210 | 380 - 500 | 380 - 575 | 99 | 0,17 |
| | | 220 - 290 | 220 - 332 | 103 | 0,31 |
| M3BP 132 | Wistro 250 | 380 - 500 | 380 - 575 | 148 | 0,25 |
| | | 220 - 290 | 220 - 332 | 146 | 0,45 |

Axial fan, N-end, for motor sizes 160 - 450, IE2

| Main motor | Fan motor type (at 50 Hz) | Voltage V at 50 Hz | Power kW | Current A |
|----------------------|---------------------------|--------------------|----------|-----------|
| M3BP 160 - 250 | M3BP 71MA 4 B14 | 400 | 0.25 | 0.64 |
| M3BP 280 - 315 ML | M3BP 80MD 4 B14 | 400 | 0.75 | 1.83 |
| M3BP 315 LK - 355 SM | M3BP 90SLD 4 B14 | 400 | 1.5 | 3.0 |
| M3BP 355 ML - 450 L | M3BP 100LD 4 B14 | 400 | 3.0 | 6.3 |

Axial fan, N-end, for motor sizes 160 - 450, IE3

| Main motor | Fan motor type (at 50 Hz) | Voltage V at 50 Hz | Power kW | Current A |
|----------------------|---------------------------|--------------------|----------|-----------|
| M3BP 160 - 250 | M3BP 71MA 4 B14 | 400 | 0.25 | 0.64 |
| M3BP 280 - 315 ML | M3BP 80MLE 4 B14 | 400 | 0.75 | 1.7 |
| M3BP 315 LK - 355 SM | M3BP 90LB 4 B14 | 400 | 1.5 | 3.3 |
| M3BP 355 ML, LK | M3BP 100MLB 4 B14 | 400 | 3.0 | 6.1 |

Fan on top, N-end

The non-axial fan available for motor sizes 280 and above is a Ziehl-Abegg fan with an integrated motor. This cooling option is suited for 400 V, 50 Hz networks and can be ordered with variant code 422.

| MV at 50 Hz in motor | Fan motor type | Voltage V | Freq. Hz | Power kW | Current A |
|----------------------|------------------|-----------|----------|----------|-----------|
| M3BP 280 | Ziehl-Abegg RH35 | 400 VY | 50 | 0.35 | 0.83 |
| | | 460 VY | 60 | 0.5 | 0.9 |
| M3BP 315 | Ziehl-Abegg RH40 | 400 VY | 50 | 0.50 | 1.0 |
| | | 460 VY | 60 | 0.8 | 1.4 |
| M3BP 355 | Ziehl-Abegg RH45 | 400 VY | 50 | 0.90 | 1.8 |
| | | 460 VY | 60 | 1.4 | 2.2 |
| M3BP 400 | Ziehl-Abegg RH50 | 400 VY | 50 | 1.55 | 3.3 |
| | | 460 VY | 60 | 2.5 | 4.3 |
| M3BP 450 | Ziehl-Abegg RH56 | 400 VY | 50 | 2.30 | 4.5 |
| | | 460 VY | 60 | 2.5 | 4.3 |

Special motor and fan on top, N-end

A special ABB fan motor type is available for motor sizes 280 and above. It is suited for environments where IP 65 is the required IP class or where the input voltage must be other than 360 – 420 V (50 Hz).

The values here are given for 400 V, but technical data for other voltages can be found in MotSize.

The centrifugal impeller used in the fan is a Ziehl-Abegg impeller. This type of cooling can be ordered with variant code 514.

Special motor and fan on top, N-end, for motor sizes 280 - 450

| Main motor | Fan motor type | Voltage V at 50 Hz | Power kW | Current A |
|----------------|-------------------|--------------------|----------|-----------|
| M3BP 280 - 315 | M3BP 80 MD 4 B34 | 400 | 0.75 | 1.83 |
| M3BP 355 | M3BP 90 SLD 4 B34 | 400 | 1.5 | 3.0 |
| M3BP 400 | M3BP 100 LD 4 B34 | 400 | 3.0 | 6.3 |
| M3BP 450 | M3BP 112 MB 4 B34 | 400 | 4.0 | 8.2 |

Accessories

Silencer for motor sizes 280 - 450

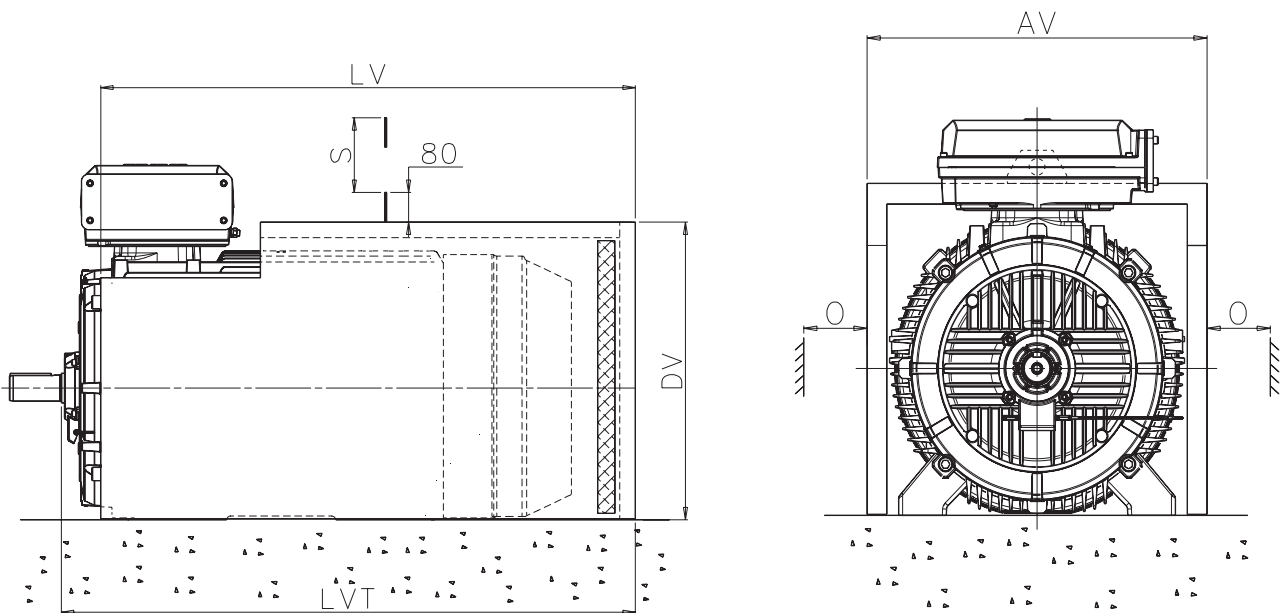

Both foot-mounted and flange-mounted motors can be fitted with a silencer to reduce noise level by about 5 - 6 dB(A). The silencer is painted blue and made of 2 mm steel sheet. The sound absorbing material is 40 mm thick polyurethane foam. On the rim there is a rubber strip for sealing on the floor. The silencer fits loosely over the motor.

The variant code for ordering a silencer is 055.

| Motor size | AV | LV | LVT | DV | O ¹⁾ | S ²⁾ | Weight kg |
|------------|------|------|------|-----|-----------------|-----------------|-----------|
| 280 SM_ | 681 | 1010 | 1090 | 616 | 50 | 762 | 38 |
| 315 SM_ | 760 | 1094 | 1191 | 697 | 60 | 852 | 47 |
| 315 ML_ | 760 | 1205 | 1302 | 697 | 60 | 852 | 51 |
| 315 LK_ | 760 | 1411 | 1508 | 697 | 60 | 852 | 58 |
| 355 SM_ | 850 | 1335 | 1441 | 777 | 65 | 958 | 62 |
| 355 ML_ | 850 | 1440 | 1546 | 777 | 65 | 958 | 67 |
| 355 LK_ | 850 | 1690 | 1796 | 777 | 65 | 958 | 77 |
| 400 L_ | 938 | 1750 | 1873 | 866 | 75 | 1045 | 88 |
| 400 LK_ | 938 | 1750 | 1873 | 866 | 75 | 1045 | 88 |
| 450 L_ | 1050 | 2110 | 2230 | 990 | 80 | 1045 | 120 |

¹⁾ Clearance for motor cooling.

²⁾ Clearance for removal of silencer.

Note: The dimensions are only valid for standard foot-mounted motors.

Accessories

Slide rails for motor sizes 160 - 250

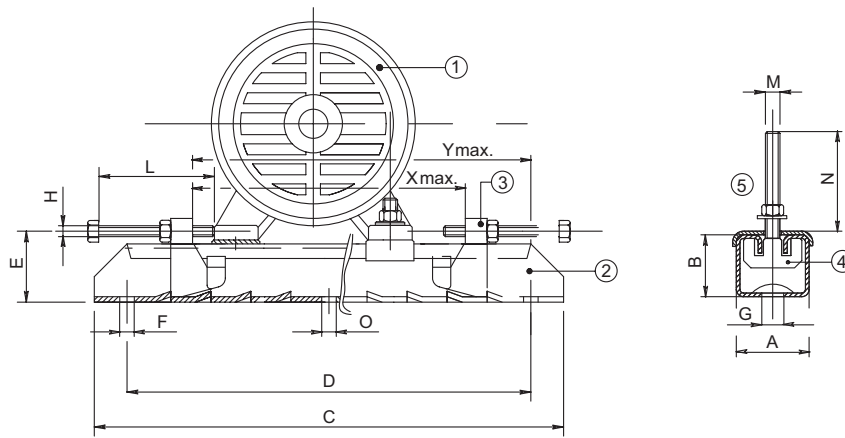

1 Motor | 2 Rail | 3 Movable adjusting bolt | 4 Fixing bolt, motor | 5 Plate

A set of slide rails includes two complete rails with screws for mounting the motor on the rails. Screws for mounting the rails on the foundation are not included. Slide rails have unmachined lower surfaces and should, before tightening down, be supported in a suitable manner.

Slide rails can be ordered with article numbers shown in the table.

| Motor size | Type | Article no. | A | B | C | D | E | F | G | H | L | M | N | O | Xmax | Ymax | Weight/ rail kg |
|-----------------------------------------|----------|-------------|-----|----|------|------|----|----|----|-----|-----|-----|----|----|------|------|--------------------|
| Frame sizes 71 to 132 on request | | | | | | | | | | | | | | | | | |
| 160 - 180 | TT180/12 | -14 | 75 | 42 | 700 | 630 | 57 | 17 | 26 | M12 | 120 | M12 | 50 | - | 520 | 580 | 12.0 |
| 200 - 225 | TT225/16 | -15 | 82 | 50 | 864 | 800 | 68 | 17 | 27 | M16 | 140 | M16 | 65 | 17 | 670 | 740 | 20.4 |
| 250 | TT280/20 | -16 | 116 | 70 | 1072 | 1000 | 90 | 20 | 27 | M18 | 150 | M20 | 80 | 20 | 870 | 940 | 43.0 |

Accessories

Slide rails for motor sizes 280 - 400

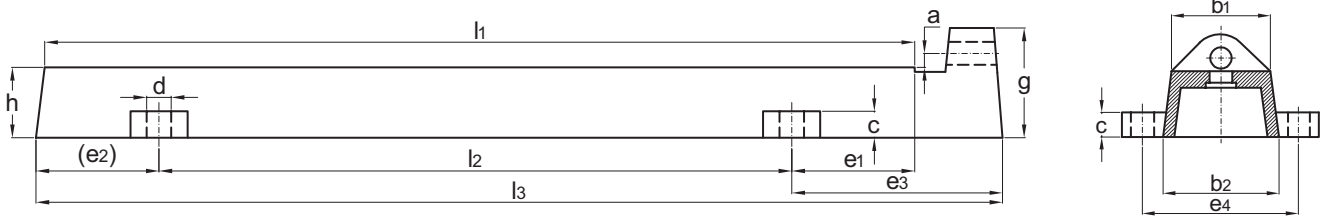

Slide rails for motor sizes 280 - 315.

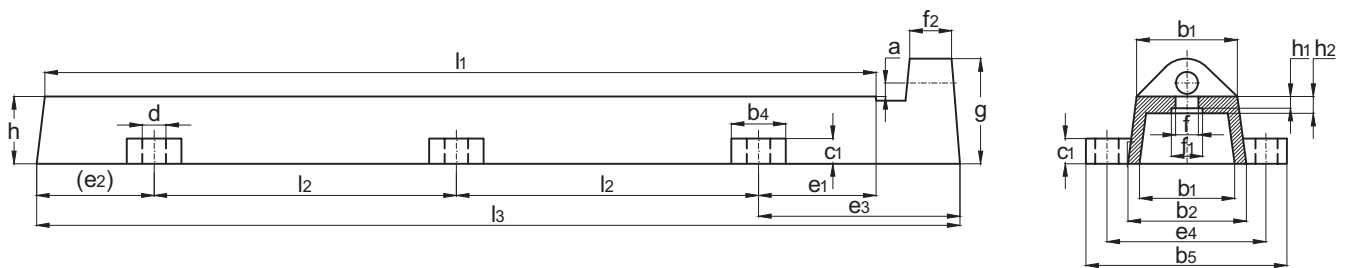

Slide rails for motor sizes 355 - 400.

Note: Slide rails that do not fulfill the DIN standard are available for motor size 450 on request.

A set of slide rails includes two complete rails with screws for mounting the motor on the rails. Screws for mounting the rails on the foundation are not included. Slide rails have unmachined lower surfaces and should be supported in a suitable manner before tightening down.

Slide rails can be ordered with article numbers shown in the table.

| Motor | | | | | | | | | | | | | | | Bolts | Horizontal | Weight |
|-----------|---------------|------|-----|------|----|----|-----|-----|----|----|-----|-----|-----|-----|---------|------------|---------|
| size | Article no. | l1 | l2 | l3 | a | h | b1 | b2 | c | d | e1 | e2 | e3 | e4 | to feet | bolts | kg/2 pc |
| 280 | 3GZF334730-55 | 800 | 600 | 900 | 16 | 75 | 100 | 120 | 35 | 28 | 100 | 100 | 200 | 165 | M20x90 | M24x300 | 50 |
| 315 | 3GZF334730-56 | 1000 | 720 | 1100 | 16 | 80 | 120 | 140 | 40 | 28 | 140 | 140 | 240 | 190 | M24x100 | M24x300 | 80 |
| 355 - 400 | 3GZF334730-57 | 1250 | 485 | 1350 | 16 | 80 | 120 | 140 | 35 | 28 | 140 | 140 | 240 | 190 | M24x100 | M24x300 | 90 |

Motors in brief

IE2 cast iron motors, sizes 71 - 132

The following tables present the standard design of IE2 cast iron motors.

| Motor size | | 71 | 80 | 90 | 100 | 112 | 132 |
|------------------------------------------------------------|--------------------|-----------------------------------------------------------------------|------------|------------|------------|---------------|------------|
| Stator and end shields | Material | Cast iron | | | | | |
| | Paint color shade | Munsell blue 8B 4.5/3.25 | | | | | |
| | Corrosion class | C3 (medium) | | | | | |
| Feet | | Integrated cast iron feet | | | | | |
| Bearings | D-end | 6203-2Z/C3 | 6204-2Z/C3 | 6205-2Z/C3 | 6206-2Z/C3 | 6206-2Z/C | 6208-2Z/C3 |
| | N-end | 6202-2Z/C3 | 6203-2Z/C3 | 6204-2Z/C3 | 6205-2Z/C3 | 6205-2Z/C3 *) | 6208-2Z/C3 |
| Axially locked bearings | | Locked at D-end | | | | | |
| Bearing seals | D-end | V-ring | | | | | |
| | N-end | Labyrinth seal in IE2, V-ring in IE3 | | | | | |
| Lubrication | | Permanently lubricated shielded bearings | | | | | |
| Measuring nipples for condition monitoring of the bearings | | Not included | | | | | |
| Rating plate | Material | Stainless steel | | | | | |
| Terminal box | Frame and cover | Cast iron | | | | | |
| | Corrosion class | C3 (medium) | | | | | |
| | Cover screws | Zinc-electroplated steel | | | | | |
| Connections | Threaded openings | 2xM16 | 2xM25 | 2xM32 | | | |
| | Terminals | 6 terminals for connection with cable lugs (not included) | | | | | |
| | Cable glands | Cable flange included, glands as option | | | | | |
| Fan | Material | Glass-fiber reinforced polypropylene | | | | | |
| Fan cover | Material | Steel | | | | | |
| | Paint color shade | Munsell blue 8B 4.5/3.25 | | | | | |
| | Corrosion class | C3 (medium) | | | | | |
| Stator winding | Material | Copper | | | | | |
| | Insulation | Insulation class F. Temperature rise class B unless otherwise stated. | | | | | |
| | Winding protection | 3 PTC thermistors, 150 °C | | | | | |
| Rotor winding | Material | Pressure die-cast aluminum | | | | | |
| Balancing method | | Half-key balancing as standard | | | | | |
| Keyway | | Closed keyway | | | | | |
| Drain holes | | Drain holes with closable plastic plugs, open on delivery | | | | | |
| Enclosure | | IP 55 | | | | | |
| Cooling method | | IC 411 | | | | | |

*) 6206-2Z/C3 in IE3

Motors in brief

IE2/IE3 cast iron motors, sizes 160 - 250

| Motor size | | 160 | 180 | 200 | 225 | 250 |
|------------------------------------------------------------|--------------------|-----------------------------------------------------------------------|---------|--------------|---------|---------|
| Stator and end shields | Material | Cast iron | | | | |
| | Paint color shade | Munsell blue 8B 4.5/3.25 | | | | |
| | Corrosion class | C3 (medium) | | | | |
| Feet | Material | Integrated cast iron feet, bolted feet when terminal box on LHS/RHS | | | | |
| Bearings | D-end | 6309/C3 | 6310/C3 | 6312/C3 | 6313/C3 | 6315/C3 |
| | N-end | 6209/C3 | 6209/C3 | 6210/C3 | 6212/C3 | 6213/C3 |
| Axially locked bearings | | Locked at D-end | | | | |
| Bearing seals | D-end | Gamma-ring | | | | |
| | N-end | Gamma-ring | | | | |
| Lubrication | | Regreasable bearings, regreasing nipples M6x1 | | | | |
| Measuring nipples for condition monitoring of the bearings | | Included | | | | |
| Rating plate | Material | Stainless steel | | | | |
| Terminal box | Frame and cover | Cast iron | | | | |
| | Corrosion class | C3 (medium) | | | | |
| | Cover screws | Zinc-electroplated steel | | | | |
| Connections | Cable entries | 2xM40, 2xM20 | | 2xM63, 2xM20 | | |
| | Terminals | 6 terminals for connection with cable lugs (not included) | | | | |
| | Cable glands | Cable flange included, glands as option | | | | |
| Fan | Material | Glass-fiber reinforced polypropylene | | | | |
| Fan cover | Material | Steel | | | | |
| | Paint color shade | Munsell blue 8B 4.5/3.25 | | | | |
| | Corrosion class | C3 (medium) | | | | |
| Stator winding | Material | Copper | | | | |
| | Insulation | Insulation class F, Temperature rise class B unless otherwise stated. | | | | |
| | Winding protection | 3 PTC thermistors, 150 °C | | | | |
| Rotor winding | Material | Pressure die-cast aluminum | | | | |
| Balancing method | | Half-key balancing as standard | | | | |
| Keyway | | Closed keyway | | | | |
| Drain holes | | Drain holes with closable plastic plugs, open on delivery | | | | |
| Enclosure | | IP 55 | | | | |
| Cooling method | | IC 411 | | | | |

Motors in brief

IE2/IE3/IE4 cast iron motors, sizes 280 - 450

| Motor size | 280 | | 315 | 355 | 400 | 450 | |
|------------------------------------------------------------|--------------------|-----------------------------------------------------------------------|-------------------------------------------------------------|-----------------------|------------------------|-----------------------------|-----------------|
| Stator and end shields | Material | Cast iron | | | | | |
| | Paint color shade | Munsell blue 8B 4.5/3.25 | | | | | |
| | Corrosion class | C3 (medium) | | | | | |
| Feet | Material | Integrated cast iron feet | | | | | |
| Bearings | D-end | 2-pole | 6316/C3 | 6316/C3 | 6316M/C3 | 6317M/C3 | 6317M/C3 |
| | | 4-12-pole | 6316/C3 | 6319/C3 | 6322/C3 | 6324/C3 | 6326M/C3 |
| | N-end | 2-pole | 6316/C3 | 6316/C3 | 6316M/C3 | 6317M/C3 | 6317M/C3 |
| | | 4-12-pole | 6316/C3 | 6316/C3 | 6316/C3 | 6319/C3 | 6322/C3 |
| Axially locked bearings | | Locked at D-end | | | | | |
| Bearing seals | D-end | V-ring or labyrinth seal | | | | | |
| | N-end | V-ring or labyrinth seal | | | | | |
| Lubrication | | Regreasable bearings, regreasing nipples M10x1 | | | | | |
| Measuring nipples for condition monitoring of the bearings | | Included | | | | | |
| Rating plate | Material | Stainless steel | | | | | |
| Terminal box | Frame and cover | Cast iron | | | | | Cover steel |
| | Corrosion class | C3 (medium) | | | | | Steel |
| | Cover screws | Zinc-electroplated steel | | | | | |
| Connections | Cable-entries | 2-4-pole | 2xM63+2xM20 | 2xM63, 2xØ48-60+2xM20 | 2xØ48-60, 60-80, 2xM20 | 2xØ60-80 (2-6-pole), 2xM2+0 | 2xØ60-80, 2xM20 |
| | | 6-8-pole | | | 2xØ32-49, 48-60, 2xM20 | 2xØ48-60 (6-pole), 2xM20 | |
| | | | See section Standard terminal box for detailed information. | | | | |
| | Terminals | 6 terminals for connection with cable lugs (not included) | | | | | |
| | Cable glands | Cable flange, glands as option | | | | | |
| Fan | Material | Glass-fiber reinforced polypropylene | | | | | |
| Fan cover | Material | Steel | | | | | |
| | Paint color shade | Munsell blue 8B 4.5/3.25 | | | | | |
| | Corrosion class | C3 (medium) | | | | | |
| Stator winding | Material | Copper | | | | | |
| | Insulation | Insulation class F, Temperature rise class B unless otherwise stated. | | | | | |
| | Winding protection | 3 PTC thermistors, 155 °C | | | | | |
| Rotor winding | Material | Pressure die-cast aluminum | | | | | |
| Balancing method | | Half-key balancing | | | | | |
| Keyway | | Open keyway | | | | | |
| Drain holes | | Drain holes with closable plastic plugs, open on delivery | | | | | |
| Enclosure | | IP 55 | | | | | |
| Cooling method | | IC 411 | | | | | |

Motor construction

Exploded view, frame size 315

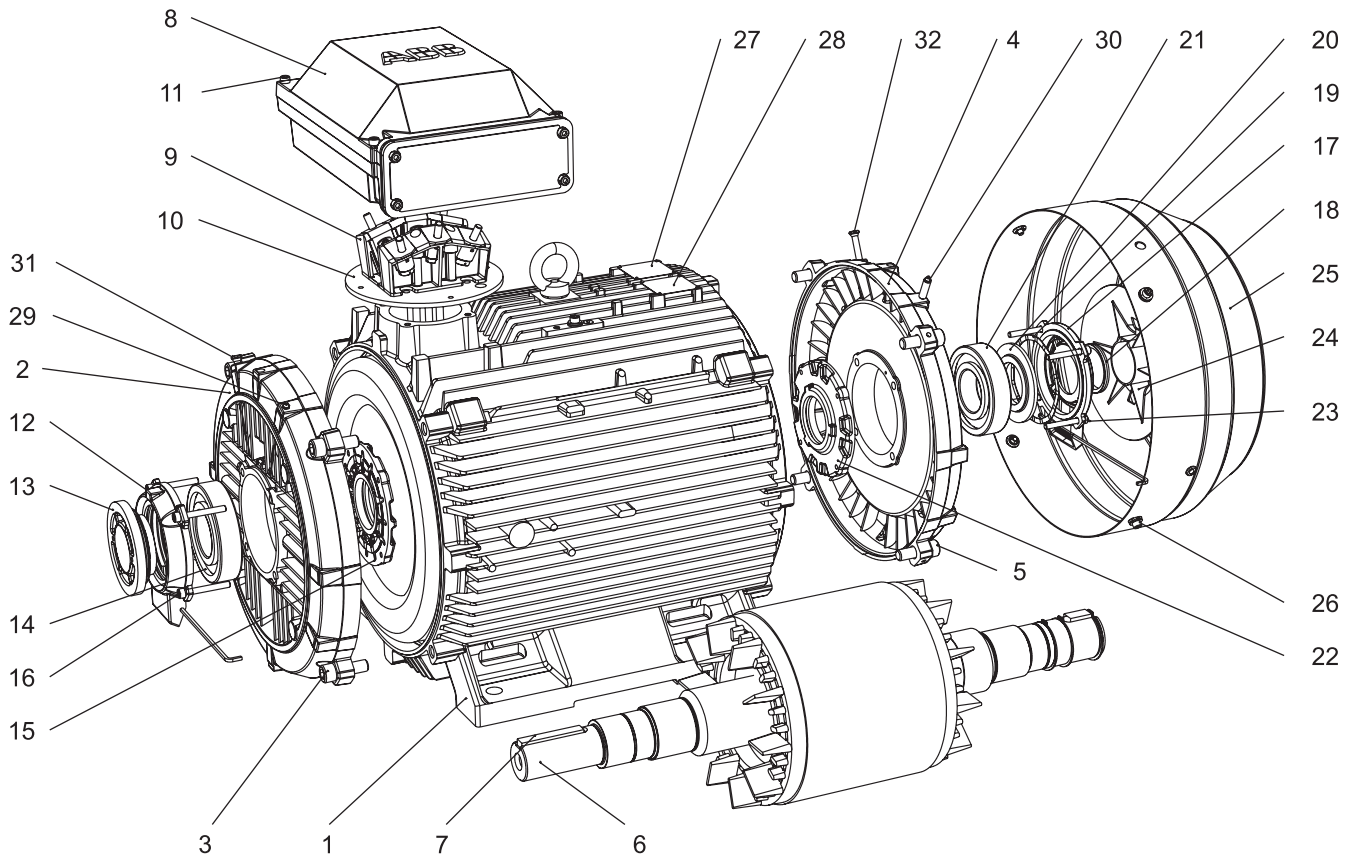

- 1 Stator frame
- 2 End shield, D-end
- 3 Screws for end shield, D-end
- 4 End shield, N-end
- 5 Screws for end shield, N-end
- 6 Rotor with shaft
- 7 Key, D-end
- 8 Terminal box
- 9 Terminal board
- 10 Intermediate flange
- 11 Screws for terminal box cover
- 12 Outer bearing cover, D-end

- 13 Valve disc with labyrinth seal, D-end; standard in 2-pole motors, V-ring in 4-8 pole motors
- 14 Bearing, D-end
- 15 Inner bearing cover, D-end
- 16 Screws for bearing cover
- 17 Outer bearing cover, N-end
- 18 Seal, N-end
- 19 Wave spring
- 20 Valve disc, N-end
- 21 Bearing, N-end
- 22 Inner bearing cover, N-end

- 23 Screws for bearing cover
- 24 Fan
- 25 Fan cover
- 26 Screws for fan cover
- 27 Rating plate
- 28 Lubrication plate
- 29 Grease nipple, D-end
- 30 Grease nipple, N-end
- 31 SPM nipple, D-end
- 32 SPM nipple, N-end

Low voltage Process performance aluminum motors

Sizes 63 to 280, 0.09 to 90 kW

| | |
|----------------------------------|------------|
| Ordering information | 84 |
| Rating plates | 85 |
| Technical data IE2 | 86 |
| 3000 r/min motors..... | 86 |
| 1500 r/min motors..... | 87 |
| 1000 r/min motors..... | 88 |
| 750 r/min motors..... | 89 |
| Technical data IE3 | 90 |
| 3000 and 1500 r/min motors..... | 90 |
| 1000 r/min motors..... | 91 |
| Variant codes | 95 |
| Mechanical design | 99 |
| Motor frame and drain holes..... | 99 |
| Bearings..... | 100 |
| Terminal box..... | 108 |
| Dimension drawings | 110 |
| Motor sizes 63 - 112..... | 110 |
| Motor sizes 71 - 132..... | 114 |
| Motor size 132..... | 115 |
| Motors sizes 160 - 180..... | 117 |
| Motor sizes 200 - 225..... | 120 |
| Motor sizes 200 - 225..... | 121 |
| Motor sizes 250 - 280..... | 126 |
| Motor sizes 250 - 280..... | 127 |
| Accessories | 132 |
| Slide rails..... | 132 |
| Aluminum motors in brief | 133 |
| Motor sizes 63 - 132..... | 133 |
| Motor sizes 160 - 280..... | 134 |

Ordering information

Explanation of the product code

| Motor type | Motor size | Product code | Code for mounting arrangement, Voltage and frequency code, Generation code followed by variant codes |
|------------|------------|-------------------------------------|------------------------------------------------------------------------------------------------------|
| M3AA | 112MB | 3GAA 112 312 | - ADE, 122, 003, etc. |
| | | 1 2 3 4 5 6 7 8 9 10 11 12 13 14... | |

When placing an order, specify motor type, size and product code according to the following example.

Example

| | |
|--------------------------------|-----------------|
| Motor type | M3AA 112 MB |
| Pole number | 4 |
| Mounting arrangement (IM-code) | IM B3 (IM 1001) |
| Rated output | 4 kW |
| Product code | 3GAA 112312-ADE |
| Variant codes if needed | |

Positions 1 to 4

3GAA: Totally enclosed motor with aluminum stator frame

Positions 5 and 6

IEC size

| | |
|-----|-----|
| 06: | 63 |
| 07: | 71 |
| 08: | 80 |
| 09: | 90 |
| 10: | 100 |
| 11: | 112 |
| 13: | 132 |
| 16: | 160 |
| 18: | 180 |
| 20: | 200 |
| 22: | 225 |
| 25: | 250 |
| 28: | 280 |

Position 7

Pole pairs

| | |
|----|--------------------|
| 1: | 2 poles |
| 2: | 4 poles |
| 3: | 6 poles |
| 4: | 8 poles |
| 5: | 10 poles |
| 6: | 12 poles |
| 7: | > 12 poles |
| 8: | Two-speed motors |
| 9: | Multi-speed motors |

Position 11

- (dash)

Position 12 (marked with black dot in data tables)

Mounting arrangement

| | |
|----|--------------------------------------------------------------------|
| A: | Foot-mounted motor |
| B: | Flange-mounted motor. Large flange with clearance holes. |
| C: | Flange-mounted motor. Small flange with tapped holes. |
| F: | Foot- and flange-mounted motor. Special flange. |
| H: | Foot- and flange-mounted motor. Large flange with clearance holes. |
| J: | Foot- and flange-mounted motor. Small flange with tapped holes. |
| N: | Flange-mounted (CI ring flange FF) |
| P: | Foot-and flange-mounted motor (CI ring flange FF) |
| V: | Flange-mounted motor. Special flange. |

Position 13 (marked with black dot in data tables)

Voltage and frequency code

Single-speed motors

| | |
|----|-------------------------------------------------------------|
| B: | 380 VΔ 50 Hz |
| D: | 400 VΔ, 415 VΔ, 690 VY 50 Hz |
| E: | 500 VΔ 50 Hz |
| F: | 500 VY 50 Hz |
| S: | 230 VΔ, 400 VY, 415 VY 50 Hz |
| T: | 660 VΔ 50 Hz |
| U: | 690 VΔ 50 Hz |
| X: | Other rated voltage, connection or frequency, 690 V maximum |

Two-speed motors

| | |
|---------|----------------------------------------------------------------------------------------------------------------|
| A: | 220 V 50 Hz |
| B: | 380 V 50 Hz |
| D: | 400 V 50 Hz |
| E: | 500 V 50 Hz |
| S: | 230 V 50 Hz |
| X: | Other rated voltage, connection or frequency, 690 V maximum |
| Remark: | For voltage code X the variant code "209 Non-standard voltage or frequency (special winding)" must be ordered. |

Position 14

Version

A, B, C...: Generation code followed by variant codes

Efficiency values are given according to IEC 60034-2-1; 2014

For detailed dimension drawings please see our web-pages 'www.abb.com/motors&generators' or contact ABB.

Positions 8 to 10

Running number

Position 11

- (dash)

Rating plates

The motor's main rating plate shows the motor's performance values with various connections at nominal speed. The rating plate also shows the efficiency level (IE2, IE3, or IE4), year of manufacture, and the lowest nominal efficiency at 100, 75, and 50 % nominal load. The material of the rating plate is aluminum as standard.

| | | | | | | |
|-----------------------------------------|----|----------------------|-------------|-------------|---------------|----|
| ABB | | 3~Motor M3AA 080 C 2 | | | IE2 CE | |
| 3GAA081313-ASE | | No. E101508P9150 | | Cl. F IP 55 | | |
| 6204-2Z/C3 | | 6203-2Z/C3 | | 11 | | kg |
| V | Hz | r/min | kW | A | Cos φ | |
| 230 D / 400 Y | 50 | 2870 | 1,10 | 4,30 / 2,50 | 0,78 | |
| 460 Y | 60 | 3485 | 1,10 | 2,20 | 0,75 | |
| IE2-50Hz-80,9(100%)-81,7(75%)-79,8(50%) | | | | | | |
| IE2-60Hz-82,8(100%) | | | | | | |
| 2011 | | | IEC 60034-1 | | | |

Motor sizes 71 to 80

| | | | | | | |
|-----------------------------------------|----|-----------------------|------|------------|---------------|--|
| ABB | | 3~Motor M3AA 100 LB 2 | | | IE2 CE | |
| 3GAA101520-ASE | | CL. F IP 55 | | IEC60034-1 | | |
| Nº. E101110P9165 | | 2011 | | | | |
| V | Hz | r/min | kW | A | Cos φ | |
| 230 D | 50 | 2920 | 3,00 | 10,00 | 0,86 | |
| 400 Y | 50 | 2920 | 3,00 | 5,80 | 0,86 | |
| 460 Y | 60 | 3530 | 3,00 | 5,10 | 0,84 | |
| IE2-50Hz-86,4(100%)-86,0(75%)-83,9(50%) | | | | | | |
| IE2-60Hz-87,5(100%) | | | | | | |
| 6306-2Z/C3 | | 6205-2Z/C3 | | 24 kg | | |

Motor sizes 90 to 132

| | | | | | | | |
|-------------------------------------------|----|-------------------------|-------|-------------|---------------|------|----|
| ABB | | 3~ Motor M3AA 225 SMB 4 | | | IE3 CE | | |
| No. | | Ins. cl. F | | IP 55 | | | |
| V | Hz | kW | r/min | A | cos φ | duty | |
| 400 | Δ | 50 | 45 | 1482 | 80.2 | 0.85 | S1 |
| 690 | Y | 50 | 45 | 1482 | 46.5 | 0.85 | S1 |
| 415 | Δ | 50 | 45 | 1483 | 78.3 | 0.84 | S1 |
| 460 | Δ | 60 | 45 | 1785 | 70.5 | 0.84 | S1 |
| 50 Hz: IE3-93.3(100%)-94.0(75%)-93.8(50%) | | | | | | | |
| 60 Hz: IE3-93.8(100%)-94.2(75%)-93.7(50%) | | | | | | | |
| 3GAA 222 220-ADK | | | | | | | |
| 6313/C3 | | 6212/C3 | | 316 kg | | | |
| spare-parts@www.abb.com/partsonline | | | | IEC 60034-1 | | | |

Motor sizes 160 to 280

Technical data

IE2 aluminum motors, 3000 r/min

IP 55 - IC 411 - Insulation class F, temperature rise class B
IE2 efficiency class according to IEC 60034-30-1; 2014

| Output kW | Motor type | Product code | Speed r/min | Efficiency IEC 60034-30-1; 2014 | | | Power factor Cosφ | Current | | Torque | | | Moment of inertia J = 1/4 GD²kgm² | Weight kg | Sound pressure Level L _{PA} dB |
|-----------------------------|-----------------------------|----------------|-------------|---------------------------------|--------------|--------------|-------------------|-----------------------|--------------------------------|-------------------|--------------------------------|--------------------------------|-----------------------------------|-----------|-----------------------------------------|
| | | | | Full load 100% | 3/4 load 75% | 1/2 load 50% | | I _N A | I _g /I _N | T _N Nm | T _r /T _N | T _b /T _N | | | |
| 3000 r/min = 2 poles | | | | 400 V 50 Hz | | | | CENELEC-design | | | | | | | |
| 0.18 | M3AA 63A 2 | 3GAA061311-••C | 2820 | 75,0 | 72,0 | 66,1 | 0,62 | 0,55 | 4,2 | 0,6 | 3,5 | 3,1 | 0,000130 | 3,9 | 54 |
| 0.25 | M3AA 63B 2 | 3GAA061312-••C | 2810 | 78,6 | 77,0 | 69,6 | 0,69 | 0,66 | 4,5 | 0,84 | 3,6 | 3,3 | 0,000160 | 4,4 | 54 |
| 0.37 | M3AA 71A 2 | 3GAA071311-••E | 2800 | 73,8 | 75,8 | 73,9 | 0,76 | 1,0 | 4,9 | 1,3 | 2,7 | 2,7 | 0,000350 | 4,9 | 58 |
| 0.55 | M3AA 71B 2 | 3GAA071312-••E | 2790 | 78,4 | 79,8 | 78,7 | 0,78 | 1,3 | 5,3 | 1,9 | 2,9 | 2,8 | 0,000450 | 5,9 | 58 |
| 0.75 | M3AA 80B 2 | 3GAA081312-••E | 2895 | 80,6 | 80,4 | 77,3 | 0,79 | 1,7 | 8,1 | 2,4 | 3,7 | 3,9 | 0,00090 | 10,5 | 60 |
| 1.1 | M3AA 80C 2 | 3GAA081313-••E | 2875 | 80,6 | 80,4 | 77,9 | 0,80 | 2,4 | 7,8 | 3,6 | 3,6 | 3,5 | 0,00120 | 11,0 | 60 |
| 1.5 | M3AA 90L 2 | 3GAA091500-••E | 2900 | 84,1 | 85,0 | 83,5 | 0,86 | 2,9 | 7,6 | 4,9 | 2,5 | 3,3 | 0,00240 | 16 | 60 |
| 2.2 | M3AA 90LB 2 | 3GAA091520-••E | 2870 | 84,6 | 85,7 | 84,9 | 0,86 | 4,4 | 6,9 | 7,3 | 2,8 | 3,2 | 0,00270 | 18 | 63 |
| 3 | M3AA 100LB 2 | 3GAA101520-••E | 2920 | 86,4 | 86,1 | 84,0 | 0,86 | 5,8 | 9,3 | 9,8 | 3,3 | 3,9 | 0,0050 | 25 | 62 |
| 4 | M3AA 112MB 2 | 3GAA111320-••E | 2885 | 86,1 | 87,0 | 88,0 | 0,88 | 7,6 | 7,6 | 13,2 | 2,5 | 2,8 | 0,00620 | 30 | 68 |
| 5.5 | M3AA 132SB 2 | 3GAA131120-••E | 2915 | 88,0 | 88,1 | 86,9 | 0,82 | 11,0 | 7,9 | 18,0 | 2,6 | 3,6 | 0,0160 | 52 | 73 |
| 7.5 | M3AA 132SC 2 | 3GAA131130-••E | 2915 | 88,3 | 89,0 | 88,4 | 0,90 | 13,6 | 7,6 | 24,5 | 2,2 | 3,2 | 0,0220 | 52 | 73 |
| 11 | M3AA 160MB 2 | 3GAA161320-••E | 2900 | 90,3 | 90,5 | 89,4 | 0,87 | 20,2 | 8,5 | 36,2 | 2,7 | 3,7 | 0,0187 | 79 | 68 |
| 11 | M3AA 160MLA 2 | 3GAA161410-••G | 2938 | 90,6 | 91,5 | 91,1 | 0,90 | 19,2 | 7,5 | 35,7 | 2,4 | 3,1 | 0,044 | 91 | 69 |
| 15 | M3AA 160M 2 | 3GAA161300-••E | 2905 | 90,4 | 90,8 | 90,0 | 0,84 | 28,5 | 9,1 | 49,3 | 3,3 | 4,0 | 0,020 | 83 | 69 |
| 15 | M3AA 160MLB 2 | 3GAA161420-••G | 2934 | 91,5 | 92,4 | 92,2 | 0,90 | 26,0 | 7,5 | 48,8 | 2,5 | 3,3 | 0,053 | 105 | 69 |
| 18.5 | M3AA 160LB 2 | 3GAA161520-••E | 2895 | 91,1 | 92,0 | 92,1 | 0,89 | 32,9 | 9,7 | 61,0 | 3,2 | 4,3 | 0,0256 | 95 | 68 |
| 18.5 | M3AA 160MLC 2 | 3GAA161430-••G | 2932 | 92,0 | 93,1 | 93,1 | 0,92 | 31,5 | 7,5 | 60,2 | 2,9 | 3,4 | 0,063 | 123 | 69 |
| 22 | M3AA 180MLA 2 | 3GAA181410-••G | 2952 | 92,2 | 92,7 | 92,2 | 0,87 | 39,5 | 7,7 | 71,1 | 2,8 | 3,3 | 0,076 | 132 | 69 |
| 30 | M3AA 200MLA 2 | 3GAA201410-••G | 2956 | 93,1 | 93,5 | 92,8 | 0,90 | 51,6 | 7,7 | 96,9 | 2,7 | 3,1 | 0,178 | 210 | 72 |
| 37 | M3AA 200MLB 2 | 3GAA201420-••G | 2959 | 93,4 | 93,7 | 92,9 | 0,90 | 63,5 | 8,2 | 119 | 3,0 | 3,3 | 0,196 | 225 | 72 |
| 45 | M3AA 225SMA 2 | 3GAA221210-••G | 2961 | 93,6 | 93,9 | 93,1 | 0,88 | 78,8 | 6,7 | 145 | 2,5 | 2,5 | 0,244 | 263 | 74 |
| 55 | M3AA 250SMA 2 | 3GAA251210-••G | 2967 | 94,1 | 94,4 | 93,8 | 0,88 | 95,8 | 6,8 | 177 | 2,2 | 2,7 | 0,507 | 304 | 75 |
| 75 | M3AA 280SMA 2 | 3GAA281210-••G | 2968 | 94,4 | 94,7 | 94,3 | 0,89 | 128 | 7,1 | 241 | 2,5 | 2,8 | 0,583 | 389 | 75 |
| 86 | ¹⁾ M3AA 280SMB 2 | 3GAA281220-••G | 2973 | 94,8 | 95,1 | 94,5 | 0,89 | 146 | 8,3 | 276 | 2,8 | 3,3 | 0,644 | 425 | 75 |
| 90 | ¹⁾ M3AA 280SMB 2 | 3GAA281229-••G | 2971 | 94,9 | 95,2 | 94,7 | 0,89 | 153 | 7,8 | 289 | 2,6 | 3,2 | 0,644 | 425 | 75 |

¹⁾ Temperature rise class F

| Output kW | Motor type | Product code | Speed r/min | Efficiency IEC 60034-30-1; 2014 | | | Power factor Cosφ | Current | | Torque | | | Moment of inertia J = 1/4 GD²kgm² | Weight kg | Sound pressure Level L _{PA} dB |
|-----------------------------|-----------------------------|----------------|-------------|---------------------------------|--------------|--------------|-------------------|---------------------------|--------------------------------|-------------------|--------------------------------|--------------------------------|-----------------------------------|-----------|-----------------------------------------|
| | | | | Full load 100% | 3/4 load 75% | 1/2 load 50% | | I _N A | I _g /I _N | T _N Nm | T _r /T _N | T _b /T _N | | | |
| 3000 r/min = 2 poles | | | | 400 V 50 Hz | | | | High-output design | | | | | | | |
| 11 | M3AA 132SMF 2 | 3GAA131260-••E | 2900 | 90,3 | 90,5 | 89,4 | 0,87 | 20,2 | 8,5 | 36,2 | 2,7 | 3,7 | 0,0187 | 77 | 68 |
| 15 | M3AA 132SMG 2 | 3GAA131270-••E | 2905 | 90,4 | 90,8 | 90,0 | 0,84 | 28,5 | 9,1 | 49,3 | 3,3 | 4,0 | 0,020 | 81 | 69 |
| 18.5 | M3AA 132SMJ 2 | 3GAA131290-••E | 2895 | 91,1 | 92,0 | 92,1 | 0,89 | 32,9 | 9,7 | 61,0 | 3,2 | 4,3 | 0,0256 | 93 | 68 |
| 22 | M3AA 160MLD 2 | 3GAA161440-••G | 2933 | 91,7 | 92,8 | 92,8 | 0,90 | 38,0 | 8,1 | 71,6 | 3,2 | 3,6 | 0,063 | 123 | 69 |
| 27 | M3AA 160MLE 2 | 3GAA161450-••G | 2939 | 92,2 | 93,1 | 93,0 | 0,90 | 46,4 | 8,8 | 87,7 | 3,4 | 3,8 | 0,072 | 145 | 69 |
| 30 | M3AA 180MLB 2 | 3GAA181420-••G | 2950 | 92,7 | 93,5 | 93,3 | 0,88 | 53,0 | 7,9 | 97,1 | 2,8 | 3,3 | 0,092 | 149 | 69 |
| 45 | M3AA 200MLC 2 | 3GAA201430-••G | 2957 | 93,3 | 93,8 | 93,2 | 0,90 | 78,2 | 8,1 | 145 | 3,1 | 3,3 | 0,196 | 225 | 72 |
| 55 | ¹⁾ M3AA 200MLD 2 | 3GAA201440-••G | 2953 | 93,8 | 94,4 | 94,3 | 0,89 | 95,0 | 7,8 | 177 | 2,9 | 3,3 | 0,217 | 241 | 72 |
| 55 | M3AA 225SMB 2 | 3GAA221220-••G | 2961 | 93,9 | 94,3 | 93,6 | 0,88 | 96,0 | 6,5 | 177 | 2,4 | 2,5 | 0,274 | 286 | 74 |
| 70 | ¹⁾ M3AA 225SMC 2 | 3GAA221230-••G | 2972 | 94,4 | 94,5 | 93,7 | 0,83 | 128 | 7,9 | 224 | 3,4 | 3,3 | 0,309 | 312 | 74 |
| 75 | ¹⁾ M3AA 225SMD 2 | 3GAA221240-••G | 2967 | 94,4 | 94,6 | 94,0 | 0,87 | 131 | 7,7 | 241 | 3,2 | 3,0 | 0,329 | 317 | 74 |
| 75 | M3AA 250SMB 2 | 3GAA251220-••G | 2970 | 94,5 | 94,8 | 94,4 | 0,89 | 128 | 7,6 | 241 | 2,8 | 3,1 | 0,583 | 351 | 75 |
| 80 | ¹⁾ M3AA 225SMD 2 | 3GAA221240-••G | 2964 | 94,4 | 94,8 | 94,3 | 0,87 | 140 | 7,3 | 257 | 3,0 | 2,8 | 0,329 | 317 | 74 |
| 90 | ¹⁾ M3AA 250SMC 2 | 3GAA251230-••G | 2971 | 95,0 | 95,3 | 94,9 | 0,89 | 153 | 7,6 | 289 | 2,5 | 3,1 | 0,644 | 386 | 75 |

¹⁾ Temperature rise class F

Technical data

IE2 aluminum motors, 1500 r/min

IP 55 - IC 411 - Insulation class F, temperature rise class B
IE2 efficiency class according to IEC 60034-30-1; 2014

| Output kW | Motor type | Product code | Speed r/min | Efficiency IEC 60034-30-1; 2014 | | | Power factor Cos ϕ | Current | | Torque | | | Moment of inertia J = 1/4 GD ² kgm ² | Weight kg | Sound pressure Level L _{PA} dB |
|----------------------|-----------------------------|----------------|-------------|---------------------------------|--------------|--------------|-------------------------|------------------|--------------------------------|-------------------|--------------------------------|--------------------------------|------------------------------------------------------------|-----------|-----------------------------------------|
| | | | | Full load 100% | 3/4 load 75% | 1/2 load 50% | | I _N A | I _S /I _N | T _N Nm | T _I /T _N | T _B /T _N | | | |
| 1500 r/min = 4 poles | | | | 400 V 50 Hz | | | | GENELEC-design | | | | | | | |
| 0.12 | M3AA 63A 4 | 3GAA062311-••C | 1400 | 65,5 | 60,4 | 51,7 | 0,57 | 0,46 | 3,1 | 0,81 | 2,7 | 2,8 | 0,000190 | 4,0 | 40 |
| 0.18 | M3AA 63B 4 | 3GAA062312-••C | 1380 | 67,3 | 63,9 | 56,7 | 0,62 | 0,62 | 3,1 | 1,24 | 2,5 | 2,6 | 0,000260 | 4,5 | 40 |
| 0.25 | M3AA 71A 4 | 3GAA072311-••E | 1365 | 65,1 | 66,0 | 62,7 | 0,76 | 0,7 | 4,0 | 1,7 | 2,0 | 2,1 | 0,000660 | 5,2 | 45 |
| 0.37 | M3AA 71B 4 | 3GAA072312-••E | 1375 | 69,7 | 71,9 | 71,1 | 0,79 | 1,0 | 3,8 | 2,5 | 2,0 | 2,2 | 0,00080 | 5,9 | 45 |
| 0.55 | M3AA 80A 4 | 3GAA082311-••E | 1375 | 72,8 | 76,1 | 75,2 | 0,77 | 1,4 | 4,5 | 3,8 | 1,8 | 2,2 | 0,00130 | 8,5 | 50 |
| 0.75 | M3AA 80E 4 | 3GAA082315-••E | 1425 | 79,8 | 80,4 | 77,9 | 0,72 | 1,9 | 6,6 | 5,0 | 3,5 | 3,6 | 0,0020 | 15,0 | 54 |
| 1.1 | M3AA 90LB 4 | 3GAA092520-••E | 1435 | 83,7 | 83,7 | 81,7 | 0,78 | 2,4 | 6,6 | 7,3 | 2,9 | 3,2 | 0,00430 | 16 | 50 |
| 1.5 | M3AA 90LD 4 | 3GAA092540-••E | 1435 | 84,2 | 84,1 | 81,9 | 0,76 | 3,3 | 7,0 | 9,9 | 3,1 | 3,5 | 0,00480 | 17 | 50 |
| 2.2 | M3AA 100LC 4 | 3GAA102530-••E | 1450 | 86,4 | 86,2 | 84,1 | 0,79 | 4,6 | 7,3 | 14,4 | 2,8 | 3,4 | 0,0090 | 25 | 54 |
| 3 | M3AA 100LD 4 | 3GAA102540-••E | 1445 | 85,7 | 86,1 | 85,1 | 0,79 | 6,3 | 7,0 | 19,8 | 2,4 | 3,0 | 0,0110 | 28 | 63 |
| 4 | M3AA 112MB 4 | 3GAA112320-••E | 1445 | 86,7 | 86,5 | 85,2 | 0,75 | 8,8 | 7,3 | 26,4 | 3,1 | 3,4 | 0,0126 | 34 | 64 |
| 5.5 | M3AA 132M 4 | 3GAA132300-••E | 1465 | 89,0 | 89,5 | 88,6 | 0,79 | 10,9 | 6,3 | 36,0 | 1,9 | 2,6 | 0,0380 | 48 | 66 |
| 7.5 | M3AA 132MA 4 | 3GAA132310-••E | 1460 | 89,1 | 89,8 | 89,4 | 0,79 | 14,7 | 6,4 | 49,0 | 1,8 | 2,6 | 0,0480 | 59 | 63 |
| 11 | M3AA 160MLA 4 | 3GAA162410-••G | 1466 | 90,4 | 91,6 | 91,3 | 0,84 | 20,9 | 6,8 | 71,6 | 2,2 | 2,8 | 0,081 | 99 | 62 |
| 11 | M3AA 160MB 4 | 3GAA162320-••E | 1460 | 90,4 | 90,8 | 89,9 | 0,79 | 21,5 | 7,7 | 71,9 | 2,1 | 3,1 | 0,0433 | 85 | 65 |
| 15 | M3AA 160MLB 4 | 3GAA162420-••G | 1470 | 91,4 | 92,3 | 92,2 | 0,83 | 28,5 | 7,1 | 97,4 | 2,6 | 3,0 | 0,099 | 118 | 62 |
| 15 | M3AA 160LB 4 | 3GAA162520-••E | 1455 | 90,6 | 91,0 | 90,3 | 0,77 | 29,8 | 7,1 | 98,4 | 2,4 | 2,9 | 0,0517 | 84 | 67 |
| 18.5 | M3AA 180MLA 4 | 3GAA182410-••G | 1477 | 91,9 | 92,8 | 92,6 | 0,84 | 34,5 | 7,2 | 119 | 2,6 | 2,9 | 0,166 | 146 | 62 |
| 22 | M3AA 180MLB 4 | 3GAA182420-••G | 1475 | 92,3 | 93,3 | 93,2 | 0,84 | 40,9 | 7,3 | 142 | 2,6 | 3,0 | 0,195 | 163 | 62 |
| 30 | M3AA 200MLA 4 | 3GAA202410-••G | 1480 | 93,2 | 94,0 | 93,7 | 0,84 | 55,2 | 7,4 | 193 | 2,8 | 3,0 | 0,309 | 218 | 63 |
| 37 | M3AA 225SMA 4 | 3GAA222210-••G | 1479 | 93,4 | 93,9 | 93,4 | 0,84 | 68,0 | 7,1 | 238 | 2,6 | 2,9 | 0,356 | 240 | 66 |
| 45 | M3AA 225SMB 4 | 3GAA222220-••G | 1480 | 93,9 | 94,3 | 93,9 | 0,85 | 81,3 | 7,5 | 290 | 2,8 | 3,2 | 0,44 | 273 | 66 |
| 55 | M3AA 250SMA 4 | 3GAA252210-••G | 1480 | 94,4 | 94,9 | 94,6 | 0,85 | 98,9 | 7,0 | 354 | 2,6 | 2,9 | 0,765 | 314 | 67 |
| 75 | M3AA 280SMA 4 | 3GAA282210-••G | 1478 | 94,3 | 94,9 | 94,6 | 0,85 | 135 | 7,1 | 484 | 2,8 | 3,0 | 0,866 | 389 | 67 |
| 85 | ¹⁾ M3AA 280SMB 4 | 3GAA282220-••G | 1480 | 94,8 | 95,3 | 95,0 | 0,84 | 153 | 8,0 | 548 | 3,4 | 3,6 | 0,941 | 418 | 67 |
| 90 | ¹⁾ M3AA 280SMB 4 | 3GAA282220-••G | 1478 | 94,6 | 95,4 | 95,2 | 0,84 | 163 | 7,7 | 581 | 3,2 | 3,4 | 0,941 | 418 | 67 |

¹⁾ Temperature rise class F

| Output kW | Motor type | Product code | Speed r/min | Efficiency IEC 60034-30-1; 2014 | | | Power factor Cos ϕ | Current | | Torque | | | Moment of inertia J = 1/4 GD ² kgm ² | Weight kg | Sound pressure Level L _{PA} dB |
|----------------------|-----------------------------|----------------|-------------|---------------------------------|--------------|--------------|-------------------------|--------------------|--------------------------------|-------------------|--------------------------------|--------------------------------|------------------------------------------------------------|-----------|-----------------------------------------|
| | | | | Full load 100% | 3/4 load 75% | 1/2 load 50% | | I _N A | I _S /I _N | T _N Nm | T _I /T _N | T _B /T _N | | | |
| 1500 r/min = 4 poles | | | | 400 V 50 Hz | | | | High-output design | | | | | | | |
| 11 | M3AA 132SMF 4 | 3GAA132260-••E | 1460 | 90,4 | 90,8 | 89,9 | 0,79 | 21,5 | 7,7 | 71,9 | 2,1 | 3,1 | 0,0433 | 83 | 65 |
| 15 | M3AA 132SMH 4 | 3GAA132280-••E | 1455 | 90,6 | 91,0 | 90,3 | 0,77 | 29,8 | 7,1 | 98,4 | 2,4 | 2,9 | 0,0517 | 82 | 67 |
| 18.5 | M3AA 160MLC 4 | 3GAA162430-••G | 1469 | 91,4 | 92,4 | 92,2 | 0,84 | 34,7 | 7,6 | 120 | 3,0 | 3,2 | 0,110 | 127 | 62 |
| 22 | ¹⁾ M3AA 160MLD 4 | 3GAA162440-••G | 1463 | 91,6 | 93,0 | 93,2 | 0,85 | 40,7 | 6,9 | 143 | 2,5 | 2,9 | 0,125 | 140 | 62 |
| 30 | ¹⁾ M3AA 180MLC 4 | 3GAA182430-••G | 1474 | 92,3 | 93,5 | 93,5 | 0,83 | 56,5 | 7,3 | 194 | 2,7 | 2,9 | 0,217 | 177 | 62 |
| 37 | M3AA 200MLB 4 | 3GAA202420-••G | 1479 | 93,4 | 94,4 | 94,4 | 0,85 | 67,2 | 7,1 | 238 | 2,6 | 2,9 | 0,343 | 234 | 63 |
| 45 | ¹⁾ M3AA 200MLC 4 | 3GAA202430-••G | 1479 | 93,6 | 94,4 | 94,2 | 0,83 | 83,6 | 7,5 | 290 | 2,9 | 3,2 | 0,366 | 246 | 63 |
| 55 | M3AA 225SMC 4 | 3GAA222230-••G | 1478 | 94,0 | 94,6 | 94,4 | 0,85 | 99,3 | 7,4 | 355 | 2,9 | 3,1 | 0,474 | 287 | 66 |
| 64 | M3AA 225SMD 4 | 3GAA222240-••G | 1480 | 94,2 | 94,6 | 94,1 | 0,85 | 115 | 8,2 | 412 | 3,3 | 3,3 | 0,542 | 314 | 66 |
| 75 | ¹⁾ M3AA 250SMB 4 | 3GAA252220-••G | 1478 | 94,4 | 95,1 | 94,8 | 0,85 | 134 | 7,3 | 484 | 2,8 | 3,1 | 0,866 | 350 | 67 |
| 90 | ¹⁾ M3AA 250SMC 4 | 3GAA252230-••G | 1478 | 94,6 | 95,3 | 95,0 | 0,84 | 163 | 7,4 | 581 | 3,1 | 3,3 | 0,941 | 377 | 67 |

¹⁾ Temperature rise class F

Technical data

IE2 aluminum motors 1000 r/min

IP 55 - IC 411 - Insulation class F, temperature rise class B
IE2 efficiency class according to IEC 60034-30-1; 2014

| Output kW | Motor type | Product code | Speed r/min | Efficiency IEC 60034-30-1; 2014 | | | Power factor Cosφ | Current | | Torque | | | Moment of inertia J = 1/4 GD ² kgm ² | Weight kg | Sound pressure Level L _{PA} dB |
|----------------------|------------------|----------------|-------------|---------------------------------|--------------|--------------|-------------------|------------------|--------------------------------|-------------------|--------------------------------|--------------------------------|------------------------------------------------------------|-----------|-----------------------------------------|
| | | | | Full load 100% | 3/4 load 75% | 1/2 load 50% | | I _N A | I _S /I _N | T _N Nm | T _r /T _N | T _v /T _N | | | |
| 1000 r/min = 6 poles | | | | 400 V 50 Hz | | | | CENELEC-design | | | | | | | |
| 0.09 | M3AA 63A 6 | 3GAA063311-••C | 910 | 47,1 | 42,5 | 32,1 | 0,56 | 0,49 | 2,1 | 0,94 | 2,1 | 2,1 | 0,00020 | 4,0 | 38 |
| 0.12 | M3AA 63B 6 | 3GAA063312-••C | 910 | 57,5 | 54,0 | 46,2 | 0,58 | 0,51 | 2,1 | 1,25 | 2,1 | 2,1 | 0,000270 | 4,5 | 38 |
| 0.18 | M3AA 71A 6 | 3GAA073311-••E | 885 | 59,5 | 61,1 | 56,5 | 0,71 | 0,6 | 3,1 | 1,9 | 1,7 | 1,9 | 0,000920 | 5,5 | 42 |
| 0.25 | M3AA 71B 6 | 3GAA073312-••E | 895 | 64,0 | 63,6 | 59,5 | 0,71 | 0,8 | 3,3 | 2,6 | 2,2 | 2,2 | 0,00120 | 6,5 | 42 |
| 0.37 | M3AA 80A 6 | 3GAA083311-••E | 905 | 68,0 | 70,7 | 68,3 | 0,73 | 1,1 | 3,6 | 3,9 | 1,6 | 2,1 | 0,0020 | 9,0 | 47 |
| 0.55 | M3AA 80B 6 | 3GAA083312-••E | 905 | 68,7 | 71,8 | 69,7 | 0,73 | 1,6 | 3,3 | 5,8 | 1,6 | 1,8 | 0,00260 | 10,0 | 47 |
| 0.75 | M3AA 90LB 6 | 3GAA093520-••E | 930 | 77,6 | 78,0 | 75,6 | 0,71 | 2,0 | 4,0 | 7,7 | 2,0 | 2,3 | 0,00480 | 18 | 44 |
| 1.1 | M3AA 90LD 6 | 3GAA093540-••E | 935 | 78,3 | 79,3 | 77,6 | 0,69 | 2,9 | 4,2 | 11,2 | 2,2 | 2,6 | 0,00560 | 20 | 44 |
| 1.5 | M3AA 100LC 6 | 3GAA103530-••E | 945 | 80,3 | 81,4 | 80,7 | 0,73 | 3,6 | 3,9 | 15,1 | 1,7 | 2,0 | 0,0090 | 26 | 49 |
| 2.2 | M3AA 112MB 6 | 3GAA113320-••E | 955 | 81,9 | 81,8 | 79,2 | 0,72 | 5,3 | 5,2 | 21,9 | 1,8 | 2,2 | 0,010 | 34 | 56 |
| 3 | M3AA 132S 6 | 3GAA133100-••E | 960 | 83,3 | 82,9 | 80,5 | 0,69 | 7,7 | 4,3 | 29,8 | 1,6 | 2,3 | 0,0310 | 46 | 57 |
| 4 | M3AA 132MB 6 | 3GAA133320-••E | 975 | 86,4 | 85,8 | 83,1 | 0,70 | 9,4 | 7,3 | 39,2 | 2,1 | 4,4 | 0,0450 | 54 | 57 |
| 4 | M3AA 132MA 6 | 3GAA133310-••E | 960 | 84,9 | 85,3 | 83,9 | 0,68 | 10,0 | 4,6 | 39,7 | 1,5 | 2,2 | 0,0380 | 46 | 61 |
| 5.5 | M3AA 132MC 6 | 3GAA133330-••E | 965 | 86,1 | 85,6 | 83,0 | 0,69 | 13,3 | 6,2 | 54,3 | 2,5 | 2,8 | 0,0490 | 59 | 61 |
| 7.5 | M3AA 160MLA 6 | 3GAA163410-••G | 975 | 88,5 | 89,9 | 89,7 | 0,79 | 15,4 | 7,4 | 73,4 | 1,7 | 3,2 | 0,087 | 98 | 59 |
| 11 | M3AA 160MLB 6 | 3GAA163420-••G | 972 | 89,3 | 90,6 | 90,5 | 0,79 | 22,5 | 7,5 | 108 | 1,9 | 2,9 | 0,114 | 125 | 59 |
| 15 | M3AA 180MLA 6 | 3GAA183410-••G | 977 | 90,5 | 91,5 | 91,0 | 0,77 | 31,0 | 5,8 | 146 | 1,8 | 2,7 | 0,168 | 148 | 59 |
| 18.5 | M3AA 200MLA 6 | 3GAA203410-••G | 988 | 91,6 | 92,2 | 91,7 | 0,80 | 36,4 | 6,7 | 178 | 2,3 | 2,9 | 0,382 | 196 | 63 |
| 22 | M3AA 200MLB 6 | 3GAA203420-••G | 987 | 92,0 | 92,9 | 92,7 | 0,82 | 42,0 | 6,6 | 212 | 2,2 | 2,8 | 0,448 | 218 | 63 |
| 30 | M3AA 225SMA 6 | 3GAA223210-••G | 986 | 92,6 | 93,3 | 92,8 | 0,83 | 56,2 | 7,0 | 290 | 2,6 | 2,9 | 0,663 | 266 | 63 |
| 37 | M3AA 250SMA 6 | 3GAA253210-••G | 989 | 93,1 | 93,8 | 93,4 | 0,82 | 69,9 | 6,8 | 357 | 2,4 | 2,7 | 1,130 | 294 | 63 |
| 45 | 1) M3AA 280SMA 6 | 3GAA283210-••G | 988 | 93,2 | 94,0 | 93,9 | 0,84 | 82,9 | 6,8 | 434 | 2,4 | 2,6 | 1,370 | 378 | 63 |
| 55 | 1) M3AA 280SMB 6 | 3GAA283220-••G | 988 | 93,2 | 94,1 | 94,0 | 0,84 | 101 | 7,1 | 531 | 2,6 | 2,8 | 1,500 | 404 | 63 |

¹⁾ Temperature rise class F

| Output kW | Motor type | Product code | Speed r/min | Efficiency IEC 60034-30-1; 2014 | | | Power factor Cosφ | Current | | Torque | | | Moment of inertia J = 1/4 GD ² kgm ² | Weight kg | Sound pressure Level L _{PA} dB |
|----------------------|------------------|----------------|-------------|---------------------------------|--------------|--------------|-------------------|--------------------|--------------------------------|-------------------|--------------------------------|--------------------------------|------------------------------------------------------------|-----------|-----------------------------------------|
| | | | | Full load 100% | 3/4 load 75% | 1/2 load 50% | | I _N A | I _S /I _N | T _N Nm | T _r /T _N | T _v /T _N | | | |
| 1000 r/min = 6 poles | | | | 400 V 50 Hz | | | | High-output design | | | | | | | |
| 15 | M3AA 160MLC 6 | 3GAA163430-••G | 971 | 89,7 | 91,2 | 91,2 | 0,77 | 31,3 | 7,3 | 147 | 1,8 | 3,6 | 0,131 | 138 | 59 |
| 18.5 | M3AA 180MLB 6 | 3GAA183420-••G | 975 | 90,7 | 92,0 | 92,0 | 0,79 | 37,2 | 5,8 | 181 | 1,7 | 2,7 | 0,198 | 162 | 59 |
| 30 | 1) M3AA 200MLC 6 | 3GAA203430-••G | 985 | 92,0 | 93,1 | 92,8 | 0,83 | 56,7 | 6,9 | 290 | 2,3 | 2,8 | 0,531 | 245 | 63 |
| 37 | M3AA 225SMB 6 | 3GAA223220-••G | 985 | 93,1 | 94,0 | 94,0 | 0,83 | 69,1 | 6,6 | 358 | 2,3 | 2,6 | 0,821 | 300 | 63 |
| 45 | M3AA 250SMB 6 | 3GAA253220-••G | 989 | 93,4 | 94,1 | 93,9 | 0,83 | 83,7 | 7,0 | 434 | 2,5 | 2,7 | 1,370 | 341 | 63 |
| 45 | 1) M3AA 225SMC 6 | 3GAA223230-••G | 984 | 92,6 | 93,9 | 94,0 | 0,83 | 84,4 | 6,4 | 436 | 2,3 | 2,6 | 0,821 | 300 | 63 |
| 55 | 1) M3AA 250SMC 6 | 3GAA253230-••G | 988 | 93,2 | 94,1 | 94,0 | 0,84 | 101 | 7,1 | 531 | 2,6 | 2,8 | 1,50 | 367 | 63 |

¹⁾ Temperature rise class F

Technical data

Aluminum motors, 750 r/min

IP 55 - IC 411 - Insulation class F, temperature rise class B
Efficiency class according to IEC 60034-30-1; 2014

| Output kW | Motor type | Product code | Speed r/min | Efficiency IEC 60034-30-1; 2014 | | | Power factor Cosφ | Current | | Torque | | | Moment of inertia J = 1/4 GD ² kgm ² | Weight kg | Sound pressure Level L _{PA} dB |
|---------------------|---------------|----------------|-------------|---------------------------------|--------------|--------------|-------------------|------------------|--------------------------------|-------------------|--------------------------------|--------------------------------|------------------------------------------------------------|-----------|-----------------------------------------|
| | | | | Full load 100% | 3/4 load 75% | 1/2 load 50% | | I _N A | I _g /I _N | T _N Nm | T _r /T _N | T _b /T _N | | | |
| 750 r/min = 8 poles | | | | 400 V 50 Hz | | | | GENELEC-design | | | | | | | |
| 0.09 | M3AA 71A 8 | 3GAA074001-••E | 675 | 48,8 | 45,2 | 37,8 | 0,57 | 0,5 | 2,5 | 1,3 | 2,2 | 2,1 | 0,000920 | 5,5 | 40 |
| 0.12 | M3AA 71B 8 | 3GAA074002-••E | 665 | 51,5 | 49,0 | 41,9 | 0,60 | 0,6 | 2,5 | 1,7 | 2,2 | 2,1 | 0,00120 | 6,5 | 43 |
| 0.18 | M3AA 80A 8 | 3GAA084001-••E | 690 | 57,2 | 55,4 | 48,8 | 0,61 | 0,7 | 2,9 | 2,4 | 2,3 | 2,3 | 0,00180 | 8,5 | 45 |
| 0.25 | M3AA 80B 8 | 3GAA084002-••E | 690 | 61,4 | 60,0 | 54,0 | 0,60 | 1,0 | 3,1 | 3,4 | 2,5 | 2,5 | 0,00240 | 9,5 | 50 |
| 0.37 | M3AA 90S 8 | 3GAA094100-••E | 695 | 57,4 | 53,8 | 45,2 | 0,56 | 1,6 | 2,7 | 5,0 | 1,7 | 2,1 | 0,00320 | 13 | 52 |
| 0.55 | M3AA 90L 8 | 3GAA094500-••E | 660 | 61,7 | 59,5 | 53,0 | 0,58 | 2,3 | 2,5 | 7,6 | 1,5 | 1,6 | 0,00430 | 16 | 52 |
| 0.75 | M3AA 100LA 8 | 3GAA104510-••E | 720 | 70,7 | 67,1 | 59,9 | 0,47 | 3,2 | 3,9 | 9,9 | 2,5 | 3,3 | 0,00690 | 20 | 46 |
| 1.1 | M3AA 100LB 8 | 3GAA104520-••E | 695 | 76,0 | 74,9 | 70,9 | 0,66 | 3,1 | 3,4 | 15,1 | 1,7 | 2,2 | 0,00820 | 23 | 53 |
| 1.5 | M3AA 112M 8 | 3GAA114300-••E | 690 | 74,4 | 74,1 | 70,6 | 0,70 | 4,1 | 3,2 | 20,7 | 1,4 | 1,9 | 0,010 | 28 | 55 |
| 2.2 | M3AA 132S 8 | 3GAA134100-••E | 715 | 77,7 | 79,2 | 77,6 | 0,65 | 6,2 | 3,4 | 29,3 | 1,3 | 1,9 | 0,0310 | 46 | 56 |
| 3 | M3AA 132M 8 | 3GAA134300-••E | 715 | 79,3 | 78,8 | 75,5 | 0,64 | 8,5 | 3,2 | 40,0 | 1,2 | 1,8 | 0,0370 | 53 | 58 |
| 4 | M3AA 160MLA 8 | 3GAA164410-••G | 728 | 84,0 | 85,1 | 83,6 | 0,67 | 10,2 | 5,4 | 52,4 | 1,5 | 2,6 | 0,068 | 84 | 59 |
| 5.5 | M3AA 160MLB 8 | 3GAA164420-••G | 726 | 84,6 | 85,9 | 84,8 | 0,67 | 13,9 | 5,6 | 72,3 | 1,4 | 2,6 | 0,085 | 98 | 59 |
| 7.5 | M3AA 160MLC 8 | 3GAA164430-••G | 727 | 86,0 | 87,3 | 86,5 | 0,65 | 19,3 | 4,7 | 98,5 | 1,5 | 2,8 | 0,132 | 137 | 59 |
| 11 | M3AA 180MLA 8 | 3GAA184410-••G | 731 | 86,9 | 88,5 | 87,9 | 0,67 | 27,3 | 4,4 | 143 | 1,8 | 2,6 | 0,214 | 175 | 59 |
| 15 | M3AA 200MLA 8 | 3GAA204410-••G | 737 | 90,1 | 91,3 | 90,8 | 0,74 | 32,4 | 5,3 | 194 | 2,0 | 2,4 | 0,45 | 217 | 60 |
| 18.5 | M3AA 225SMA 8 | 3GAA224210-••G | 739 | 91,0 | 92,0 | 91,5 | 0,73 | 40,1 | 5,2 | 239 | 2,0 | 2,3 | 0,669 | 266 | 63 |
| 22 | M3AA 225SMB 8 | 3GAA224220-••G | 738 | 91,6 | 92,3 | 92,0 | 0,74 | 46,8 | 5,5 | 284 | 2,0 | 2,3 | 0,722 | 279 | 63 |
| 30 | M3AA 250SMA 8 | 3GAA254210-••G | 742 | 92,3 | 92,8 | 92,2 | 0,71 | 66,0 | 5,8 | 386 | 2,6 | 2,4 | 1,400 | 340 | 63 |
| 37 | M3AA 280SMA 8 | 3GAA284031-••G | 740 | 92,2 | 93,0 | 92,6 | 0,74 | 78,1 | 5,6 | 477 | 2,4 | 2,3 | 1,510 | 403 | 63 |

| Output kW | Motor type | Product code | Speed r/min | Efficiency IEC 60034-30-1; 2014 | | | Power factor Cosφ | Current | | Torque | | | Moment of inertia J = 1/4 GD ² kgm ² | Weight kg | Sound pressure Level L _{PA} dB |
|---------------------|---------------|----------------|-------------|---------------------------------|--------------|--------------|-------------------|--------------------|--------------------------------|-------------------|--------------------------------|--------------------------------|------------------------------------------------------------|-----------|-----------------------------------------|
| | | | | Full load 100% | 3/4 load 75% | 1/2 load 50% | | I _N A | I _g /I _N | T _N Nm | T _r /T _N | T _b /T _N | | | |
| 750 r/min = 8 poles | | | | 400 V 50 Hz | | | | High-output design | | | | | | | |
| 0.18 | M3AA 71C 8 | 3GAA074003-••E | 660 | 49,8 | 48,5 | 41,7 | 0,63 | 0,8 | 2,7 | 2,6 | 2,1 | 2,0 | 0,00150 | 7,0 | 40 |
| 0.37 | M3AA 80C 8 | 3GAA084003-••E | 685 | 63,1 | 63,2 | 58,1 | 0,62 | 1,4 | 3,3 | 5,1 | 2,3 | 2,3 | 0,00310 | 11,0 | 45 |
| 0.75 ¹⁾ | M3AA 90LF 8 | 3GAA094560-••E | 635 | 58,5 | 60,7 | 56,2 | 0,60 | 3,0 | 2,7 | 11,2 | 1,7 | 2,0 | 0,00480 | 18 | 43 |
| 1.5 ¹⁾ | M3AA 100LG 8 | 3GAA104570-••E | 685 | 70,7 | 70,9 | 67,3 | 0,64 | 4,7 | 3,1 | 20,9 | 1,9 | 2,0 | 0,0090 | 26 | 46 |
| 3.8 ¹⁾ | M3AA 132MF 8 | 3GAA134360-••E | 710 | 76,7 | 79,3 | 78,1 | 0,68 | 10,5 | 3,7 | 51,1 | 1,4 | 2,5 | 0,0490 | 54 | 68 |
| 18.5 | M3AA 200MLB 8 | 3GAA204420-••G | 739 | 90,1 | 90,9 | 90,3 | 0,74 | 40,0 | 5,4 | 239 | 2,1 | 2,3 | 0,530 | 245 | 60 |
| 30 | M3AA 225SMC 8 | 3GAA224230-••G | 737 | 91,6 | 92,6 | 92,4 | 0,73 | 64,7 | 5,6 | 388 | 2,3 | 2,4 | 0,828 | 300 | 63 |
| 37 | M3AA 250SMB 8 | 3GAA254220-••G | 740 | 92,7 | 93,6 | 93,4 | 0,73 | 78,9 | 5,4 | 477 | 2,6 | 2,3 | 1,510 | 367 | 63 |
| 45 ¹⁾ | M3AA 250SMC 8 | 3GAA254230-••G | 738 | 92,2 | 93,4 | 93,4 | 0,74 | 95,1 | 5,6 | 582 | 2,3 | 2,4 | 1,510 | 367 | 63 |

¹⁾ Temperature rise class F

Technical data

IE3 aluminum motors, 3000 and 1500 r/min

IP 55 - IC 411 - Insulation class F, temperature rise class B
IE3 efficiency class according to IEC 60034-30-1; 2014

| Output kW | Motor type | Product code | Speed r/min | Efficiency IEC 60034-30-1; 2014 | | | Power factor Cos ϕ | Current | | Torque | | | Moment of inertia J = 1/4 GD ² kgm ² | Weight kg | Sound pressure Level L _{PA} dB |
|-----------------------------|---------------|----------------|-------------|---------------------------------|--------------|--------------|-------------------------|-----------------------|--------------------------------|-------------------|--------------------------------|--------------------------------|------------------------------------------------------------|-----------|-----------------------------------------|
| | | | | Full load 100% | 3/4 load 75% | 1/2 load 50% | | I _N A | I _S /I _N | T _N Nm | T _I /T _N | T _v /T _N | | | |
| 3000 r/min = 2 poles | | | | 400 V 50 Hz | | | | CENELEC-design | | | | | | | |
| 0.75 | M3AA 80B 2 | 3GAA081320-••J | 2885 | 80,7 | 80,9 | 80,2 | 0,76 | 1,7 | 7,5 | 2,5 | 4,1 | 4,6 | 0,0020 | 9,4 | 60 |
| 1.1 | M3AA 80MC 2 | 3GAA081330-••J | 2871 | 82,7 | 82,8 | 80,7 | 0,80 | 2,4 | 7,6 | 3,7 | 4,0 | 4,2 | 0,0020 | 11 | 60 |
| 1.5 | M3AA 90L 2 | 3GAA091500-••J | 2900 | 84,4 | 84,6 | 83,1 | 0,86 | 3,0 | 6,7 | 4,9 | 2,6 | 3,2 | 0,0020 | 16 | 60 |
| 2.2 | M3AA 90LB 2 | 3GAA091520-••J | 2903 | 85,9 | 86,3 | 84,9 | 0,79 | 4,7 | 7,4 | 7,2 | 3,2 | 3,8 | 0,0030 | 18 | 63 |
| 3 | M3AA 100LB 2 | 3GAA101520-••J | 2897 | 87,5 | 88,5 | 88,6 | 0,93 | 5,4 | 7,6 | 9,9 | 2,7 | 3,1 | 0,0090 | 31 | 62 |
| 4 | M3AA 112MB 2 | 3GAA111320-••J | 2873 | 88,5 | 89,7 | 89,9 | 0,92 | 7,2 | 8,5 | 13,2 | 3,2 | 3,9 | 0,0130 | 35 | 68 |
| 5.5 | M3AA 132SB 2 | 3GAA131120-••J | 2914 | 89,2 | 89,4 | 88,3 | 0,91 | 9,8 | 8,4 | 18,0 | 2,6 | 4,5 | 0,0210 | 56 | 73 |
| 7.5 | M3AA 132SC 2 | 3GAA131130-••J | 2898 | 90,5 | 91,0 | 90,6 | 0,91 | 13,0 | 8,1 | 24,7 | 2,8 | 3,9 | 0,0230 | 63 | 73 |
| 22 | M3AA 180MLA 2 | 3GAA181410-••L | 2944 | 92,7 | 93,5 | 93,4 | 0,90 | 38,0 | 8,4 | 71,4 | 3,2 | 3,7 | 0,071 | 133 | 74 |
| 30 | M3AA 200MLA 2 | 3GAA201410-••L | 2957 | 93,3 | 94,0 | 93,9 | 0,88 | 52,7 | 8,7 | 96,9 | 3,0 | 3,8 | 0,104 | 171 | 74 |
| 37 | M3AA 200MLB 2 | 3GAA201420-••L | 2952 | 93,7 | 94,5 | 94,5 | 0,88 | 64,7 | 8,7 | 120 | 3,1 | 3,7 | 0,115 | 185 | 74 |
| 45 | M3AA 225SMA 2 | 3GAA221210-••L | 2955 | 94,0 | 94,9 | 95,0 | 0,89 | 77,6 | 8,0 | 145 | 2,9 | 3,3 | 0,214 | 254 | 77 |
| 55 | M3AA 250SMA 2 | 3GAA251210-••L | 2966 | 94,3 | 94,6 | 94,1 | 0,88 | 95,6 | 7,4 | 177 | 2,9 | 2,9 | 0,274 | 302 | 79 |
| 75 | M3AA 280SMA 2 | 3GAA281210-••L | 2971 | 94,7 | 95,1 | 94,8 | 0,90 | 127 | 7,9 | 241 | 2,8 | 3,3 | 0,644 | 413 | 81 |
| 90 | M3AA 280SMB 2 | 3GAA281220-••L | 2968 | 95,0 | 95,4 | 95,0 | 0,90 | 151 | 8,4 | 290 | 2,7 | 3,4 | 0,644 | 421 | 81 |

| Output kW | Motor type | Product code | Speed r/min | Efficiency IEC 60034-30-1; 2014 | | | Power factor Cos ϕ | Current | | Torque | | | Moment of inertia J = 1/4 GD ² kgm ² | Weight kg | Sound pressure Level L _{PA} dB |
|-----------------------------|---------------|----------------|-------------|---------------------------------|--------------|--------------|-------------------------|-----------------------|--------------------------------|-------------------|--------------------------------|--------------------------------|------------------------------------------------------------|-----------|-----------------------------------------|
| | | | | Full load 100% | 3/4 load 75% | 1/2 load 50% | | I _N A | I _S /I _N | T _N Nm | T _I /T _N | T _v /T _N | | | |
| 1500 r/min = 4 poles | | | | 400 V 50 Hz | | | | CENELEC-design | | | | | | | |
| 0.75 | M3AA 80ME 4 | 3GAA082350-••J | 1437 | 82,5 | 82,8 | 81,0 | 0,73 | 1,9 | 5,9 | 5,0 | 3,5 | 3,8 | 0,0040 | 13 | 54 |
| 1.1 | M3AA 90LB 4 | 3GAA092520-••J | 1437 | 84,1 | 83,7 | 81,2 | 0,80 | 2,5 | 8,0 | 7,3 | 3,3 | 3,8 | 0,0070 | 17 | 50 |
| 1.5 | M3AA 90LD 4 | 3GAA092540-••J | 1445 | 85,3 | 85,0 | 82,7 | 0,75 | 3,3 | 7,6 | 10,0 | 3,4 | 4,1 | 0,0070 | 20 | 50 |
| 2.2 | M3AA 100LC 4 | 3GAA102530-••J | 1455 | 86,7 | 86,6 | 84,6 | 0,80 | 4,6 | 7,9 | 14,4 | 3,2 | 4,0 | 0,0110 | 25 | 54 |
| 3 | M3AA 100LD 4 | 3GAA102540-••J | 1445 | 87,9 | 88,4 | 87,8 | 0,83 | 5,9 | 7,7 | 19,8 | 2,8 | 3,5 | 0,0140 | 32 | 63 |
| 4 | M3AA 112MB 4 | 3GAA112320-••J | 1451 | 88,6 | 89,4 | 89,0 | 0,77 | 8,6 | 7,6 | 26,3 | 3,1 | 4,1 | 0,0180 | 34 | 64 |
| 5.5 | M3AA 132M 4 | 3GAA132300-••J | 1460 | 89,6 | 90,1 | 89,6 | 0,82 | 11,0 | 6,6 | 35,9 | 2,2 | 3,3 | 0,0310 | 48 | 66 |
| 7.5 | M3AA 132MA 4 | 3GAA132310-••J | 1462 | 90,6 | 91,1 | 90,5 | 0,79 | 15,6 | 6,7 | 48,9 | 2,5 | 3,4 | 0,0370 | 59 | 63 |
| 18.5 | M3AA 180MLA 4 | 3GAA182410-••L | 1473 | 92,6 | 93,3 | 93,1 | 0,82 | 35,1 | 8,3 | 120 | 3,1 | 3,5 | 0,124 | 137 | 67 |
| 30 | M3AA 200MLA 4 | 3GAA202410-••L | 1476 | 93,6 | 94,0 | 93,8 | 0,85 | 54,6 | 8,1 | 194 | 2,9 | 3,4 | 0,0 | 193 | 63 |
| 37 | M3AA 225SMA 4 | 3GAA222210-••L | 1480 | 93,9 | 94,8 | 94,8 | 0,82 | 69,3 | 7,5 | 239 | 2,8 | 2,9 | 0,362 | 249 | 68 |
| 55 | M3AA 250SMA 4 | 3GAA252210-••L | 1478 | 94,6 | 95,3 | 95,1 | 0,84 | 99,9 | 7,7 | 355 | 3,3 | 3,3 | 0,536 | 331 | 71 |
| 75 | M3AA 280SMA 4 | 3GAA282210-••L | 1482 | 95,0 | 95,5 | 95,3 | 0,82 | 138 | 7,9 | 483 | 3,6 | 3,8 | 0,941 | 410 | 73 |

Note! For missing motor types on generation J and L list please refer to K generation data.

Technical data

IE3 aluminum motors, 1000 r/min

IP 55 - IC 411 - Insulation class F, temperature rise class B
IE3 efficiency class according to IEC 60034-30-1; 2014

| Output kW | Motor type | Product code | Speed r/min | Efficiency IEC 60034-30-1; 2014 | | | Power factor Cosφ | Current | | Torque | | | Moment of inertia J = 1/4 GD ² kgm ² | Weight kg | Sound pressure Level L _{PA} dB |
|----------------------|---------------|----------------|----------------|------------------------------------|-----------------|-----------------|-------------------------|---------------------|--------------------------------|----------------------|--------------------------------|--------------------------------|---------------------------------------------------------------------|--------------|--------------------------------------------------|
| | | | | Full load 100% | 3/4 load 75% | 1/2 load 50% | | I _N A | I _G /I _N | T _N Nm | T _r /T _N | T _b /T _N | | | |
| 1000 r/min = 6 poles | | | | 400 V 50 Hz | | | | GENELEC-design | | | | | | | |
| 0.75 | M3AA 90LB 6 | 3GAA093520-••J | 930 | 78,9 | 78,9 | 76,7 | 0,68 | 2,1 | 3,9 | 7,7 | 2,3 | 2,7 | 0,0070 | 17 | 44 |
| 1.1 | M3AA 90LD 6 | 3GAA093540-••J | 928 | 81,0 | 81,7 | 81,2 | 0,77 | 2,7 | 4,0 | 11,3 | 1,7 | 2,2 | 0,0070 | 19 | 44 |
| 1.5 | M3AA 100LC 6 | 3GAA103530-••J | 962 | 84,7 | 85,0 | 83,3 | 0,69 | 3,6 | 5,3 | 14,9 | 2,5 | 3,1 | 0,0140 | 28 | 49 |
| 2.2 | M3AA 112MB 6 | 3GAA113320-••J | 960 | 84,3 | 85,0 | 84,0 | 0,65 | 5,9 | 5,3 | 21,9 | 2,3 | 3,0 | 0,0180 | 33 | 56 |
| 3 | M3AA 132S 6 | 3GAA133100-••J | 972 | 85,6 | 85,5 | 83,6 | 0,69 | 7,4 | 5,3 | 29,5 | 1,8 | 3,0 | 0,0310 | 48 | 57 |
| 4 | M3AA 132MA 6 | 3GAA133310-••J | 964 | 86,8 | 88,0 | 87,8 | 0,75 | 8,9 | 4,5 | 39,1 | 1,8 | 3,0 | 0,0390 | 60 | 61 |
| 5.5 | M3AA 132MC 6 | 3GAA133330-••J | 970 | 88,5 | 89,4 | 88,8 | 0,67 | 13,3 | 6,1 | 54,2 | 2,3 | 3,1 | 0,0440 | 64 | 61 |
| 18.5 | M3AA 200MLA 6 | 3GAA203410-••L | 980 | 91,7 | 92,5 | 92,0 | 0,75 | 38,8 | 6,4 | 180 | 2,1 | 3,1 | 0,220 | 177 | 65 |
| 37 | M3AA 250SMA 6 | 3GAA253210-••L | 985 | 93,3 | 94,2 | 94,0 | 0,80 | 71,5 | 7,0 | 359 | 2,7 | 3,0 | 0,813 | 320 | 68 |
| 45 | M3AA 280SMA 6 | 3GAA283210-••L | 991 | 93,7 | 94,1 | 93,6 | 0,81 | 85,5 | 7,6 | 434 | 2,9 | 3,3 | 1,50 | 399 | 68 |
| 55 | M3AA 280SMB 6 | 3GAA283220-••L | 989 | 94,1 | 94,7 | 94,4 | 0,80 | 105 | 7,1 | 531 | 3,0 | 3,1 | 1,490 | 400 | 68 |

Note! For missing motor types on generation J and L list please refer to K generation data.

Technical data

IE3 aluminum motors, 3000 r/min

IP 55 - IC 411 - Insulation class F, temperature rise class B
IE3 efficiency class according to IEC 60034-30-1; 2014

| Output kW | Motor type | Product code | Speed r/min | Efficiency IEC 60034-30-1; 2014 | | | Power factor Cosφ | Current | | Torque | | | Moment of inertia J = 1/4 GD ² kgm ² | Weight kg | Sound pressure Level L _{PA} dB |
|----------------------|---------------|----------------|-------------|---------------------------------|--------------|--------------|-------------------|------------------|--------------------------------|-------------------|--------------------------------|--------------------------------|------------------------------------------------------------|-----------|-----------------------------------------|
| | | | | Full load 100% | 3/4 load 75% | 1/2 load 50% | | I _N A | I _S /I _N | T _N Nm | T _r /T _N | T _v /T _N | | | |
| 3000 r/min = 2 poles | | | | 400 V 50 Hz | | | | CENELEC-design | | | | | | | |
| 11 | M3AA 160MLA 2 | 3GAA161410-••K | 2943 | 92,1 | 92,7 | 92,4 | 0,92 | 18,7 | 8,1 | 35,6 | 2,7 | 3,4 | 0,0520 | 106 | 69 |
| 15 | M3AA 160MLB 2 | 3GAA161420-••K | 2943 | 92,5 | 93,4 | 93,2 | 0,92 | 25,4 | 8,4 | 48,6 | 3,1 | 3,4 | 0,0620 | 123 | 69 |
| 18.5 | M3AA 160MLC 2 | 3GAA161430-••K | 2942 | 93,1 | 93,9 | 93,9 | 0,93 | 30,8 | 8,3 | 60,0 | 3,1 | 3,6 | 0,0720 | 137 | 69 |
| 22 | M3AA 180MLA 2 | 3GAA181410-••K | 2957 | 93,2 | 93,9 | 93,8 | 0,91 | 37,4 | 8,1 | 71,0 | 2,6 | 3,2 | 0,116 | 176 | 69 |
| 30 | M3AA 200MLA 2 | 3GAA201410-••K | 2958 | 94,2 | 94,9 | 94,7 | 0,90 | 51,0 | 7,8 | 96,8 | 2,8 | 3,1 | 0,196 | 225 | 72 |
| 37 | M3AA 200MLB 2 | 3GAA201420-••K | 2960 | 94,7 | 95,2 | 95,0 | 0,91 | 61,9 | 8,8 | 119 | 3,1 | 3,4 | 0,217 | 241 | 72 |
| 45 | M3AA 225SMA 2 | 3GAA221210-••K | 2972 | 94,9 | 95,1 | 94,7 | 0,89 | 76,8 | 7,8 | 144 | 3,1 | 3,0 | 0,323 | 326 | 74 |
| 55 | M3AA 250SMA 2 | 3GAA251210-••K | 2975 | 95,2 | 95,4 | 95,0 | 0,89 | 93,6 | 8,0 | 176 | 2,8 | 3,3 | 0,579 | 351 | 75 |

| Output kW | Motor type | Product code | Speed r/min | Efficiency IEC 60034-30-1; 2014 | | | Power factor Cosφ | Current | | Torque | | | Moment of inertia J = 1/4 GD ² kgm ² | Weight kg | Sound pressure Level L _{PA} dB |
|----------------------|---------------|----------------|-------------|---------------------------------|--------------|--------------|-------------------|--------------------|--------------------------------|-------------------|--------------------------------|--------------------------------|------------------------------------------------------------|-----------|-----------------------------------------|
| | | | | Full load 100% | 3/4 load 75% | 1/2 load 50% | | I _N A | I _S /I _N | T _N Nm | T _r /T _N | T _v /T _N | | | |
| 3000 r/min = 2 poles | | | | 400 V 50 Hz | | | | High-output design | | | | | | | |
| 22 | M3AA 160MLD 2 | 3GAA161440-••K | 2944 | 92,7 | 93,5 | 93,4 | 0,90 | 38,0 | 8,4 | 71,4 | 3,2 | 3,7 | 0,0710 | 131 | 74 |
| 30 | M3AA 180MLB 2 | 3GAA181420-••K | 2957 | 93,3 | 94,0 | 93,9 | 0,88 | 52,7 | 8,7 | 96,9 | 3,0 | 3,8 | 0,104 | 162 | 74 |
| 37 | M3AA 180MLC 2 | 3GAA181430-••K | 2952 | 93,7 | 94,5 | 94,5 | 0,88 | 64,7 | 8,7 | 120 | 3,1 | 3,7 | 0,115 | 176 | 74 |
| 45 | M3AA 200MLC 2 | 3GAA201430-••K | 2955 | 94,0 | 94,9 | 95,0 | 0,89 | 77,6 | 8,0 | 145 | 2,9 | 3,3 | 0,214 | 250 | 77 |
| 55 | M3AA 225SMB 2 | 3GAA221220-••K | 2966 | 94,3 | 94,6 | 94,1 | 0,88 | 95,6 | 7,4 | 177 | 2,9 | 2,9 | 0,274 | 288 | 79 |
| 75 | M3AA 225SMC 2 | 3GAA221230-••K | 2966 | 94,7 | 95,1 | 94,7 | 0,88 | 129,0 | 8,1 | 241 | 3,3 | 3,0 | 0,329 | 328 | 79 |
| 75 | M3AA 250SMB 2 | 3GAA251220-••K | 2971 | 94,7 | 95,1 | 94,8 | 0,90 | 127,0 | 7,9 | 241 | 2,8 | 3,3 | 0,644 | 405 | 81 |
| 90 | M3AA 250SMC 2 | 3GAA251230-••K | 2968 | 95,0 | 95,4 | 95,0 | 0,90 | 151,0 | 8,4 | 290 | 2,7 | 3,4 | 0,644 | 414 | 81 |

Note! For missing motor types on generation K list please refer to previous page (L generation data)

Technical data

IE3 aluminum motors, 1500 r/min

IP 55 - IC 411 - Insulation class F, temperature rise class B
IE3 efficiency class according to IEC 60034-30-1; 2014

| Output kW | Motor type | Product code | Speed r/min | Efficiency IEC 60034-30-1; 2014 | | | Power factor Cosφ | Current | | | Torque | | | Moment of inertia J = 1/4 GD ² kgm ² | Weight kg | Sound pressure Level L _{PA} dB |
|-----------------------------|---------------|----------------|----------------|------------------------------------|-----------------|-----------------|-------------------------|-----------------------|--------------------------------|----------------------|--------------------------------|--------------------------------|-------|---------------------------------------------------------------------|--------------|--------------------------------------------------|
| | | | | Full load 100% | 3/4 load 75% | 1/2 load 50% | | I _N A | I _S /I _N | T _N Nm | T _r /T _N | T _b /T _N | | | | |
| 1500 r/min = 4 poles | | | | 400 V 50 Hz | | | | CENELEC-design | | | | | | | | |
| 11 | M3AA 160MLA 4 | 3GAA162410-••K | 1473 | 92,2 | 93,0 | 92,7 | 0,84 | 20,4 | 7,7 | 71,3 | 2,6 | 2,9 | 0,108 | 126 | 62 | |
| 15 | M3AA 160MLB 4 | 3GAA162420-••K | 1474 | 92,6 | 93,4 | 93,2 | 0,84 | 27,8 | 7,9 | 97,1 | 2,8 | 3,3 | 0,125 | 140 | 62 | |
| 18.5 | M3AA 180MLA 4 | 3GAA182410-••K | 1481 | 93,3 | 94,0 | 93,8 | 0,82 | 34,9 | 7,6 | 119 | 3,0 | 3,1 | 0,217 | 177 | 62 | |
| 22 | M3AA 180MLB 4 | 3GAA182420-••K | 1480 | 93,3 | 94,1 | 94,1 | 0,82 | 41,5 | 8,2 | 141 | 2,8 | 3,1 | 0,217 | 176 | 62 | |
| 30 | M3AA 200MLA 4 | 3GAA202410-••K | 1484 | 94,4 | 94,8 | 94,6 | 0,84 | 54,6 | 8,3 | 193 | 3,0 | 3,3 | 0,366 | 246 | 63 | |
| 37 | M3AA 225SMA 4 | 3GAA222210-••K | 1482 | 94,9 | 95,5 | 95,4 | 0,86 | 65,4 | 7,7 | 238 | 2,8 | 3,1 | 0,536 | 315 | 66 | |
| 45 | M3AA 225SMB 4 | 3GAA222220-••K | 1482 | 95,2 | 95,6 | 95,5 | 0,85 | 80,2 | 7,9 | 289 | 2,8 | 3,2 | 0,536 | 316 | 66 | |
| 55 | M3AA 250SMA 4 | 3GAA252210-••K | 1485 | 95,4 | 95,9 | 95,7 | 0,85 | 97,8 | 7,9 | 353 | 3,0 | 3,3 | 0,933 | 376 | 67 | |

| Output kW | Motor type | Product code | Speed r/min | Efficiency IEC 60034-30-1; 2014 | | | Power factor Cosφ | Current | | | Torque | | | Moment of inertia J = 1/4 GD ² kgm ² | Weight kg | Sound pressure Level L _{PA} dB |
|-----------------------------|---------------|----------------|----------------|------------------------------------|-----------------|-----------------|-------------------------|---------------------------|--------------------------------|----------------------|--------------------------------|--------------------------------|-------|---------------------------------------------------------------------|--------------|--------------------------------------------------|
| | | | | Full load 100% | 3/4 load 75% | 1/2 load 50% | | I _N A | I _S /I _N | T _N Nm | T _r /T _N | T _b /T _N | | | | |
| 1500 r/min = 4 poles | | | | 400 V 50 Hz | | | | High-output design | | | | | | | | |
| 18.5 | M3AA 160MLC 4 | 3GAA162430-••K | 1473 | 92,6 | 93,3 | 93,1 | 0,82 | 35,1 | 8,3 | 120 | 3,1 | 3,5 | 0,124 | 135 | 67 | |
| 37 | M3AA 200MLB 4 | 3GAA202420-••K | 1480 | 93,9 | 94,8 | 94,8 | 0,82 | 69,3 | 7,5 | 239 | 2,8 | 2,9 | 0,362 | 244 | 68 | |
| 55 | M3AA 225SMC 4 | 3GAA222230-••K | 1478 | 94,6 | 95,3 | 95,1 | 0,84 | 99,9 | 7,7 | 355 | 3,3 | 3,3 | 0,536 | 318 | 71 | |
| 75 | M3AA 250SMB 4 | 3GAA252220-••K | 1482 | 95,0 | 95,4 | 95,0 | 0,84 | 135 | 7,9 | 483 | 3,3 | 3,5 | 0,941 | 389 | 73 | |

Note! For missing motor types on generation K list please refer to previous page (L generation data)

Technical data

IE3 aluminum motors, 1000 r/min

IP 55 - IC 411 - Insulation class F, temperature rise class B
IE3 efficiency class according to IEC 60034-30-1; 2014

| Output kW | Motor type | Product code | Speed r/min | Efficiency IEC 60034-30-1; 2014 | | | Power factor Cosφ | Current | | Torque | | | Moment of inertia J = 1/4 GD ² kgm ² | Weight kg | Sound pressure Level L _{PA} dB |
|-----------------------------|---------------|----------------|----------------|------------------------------------|-----------------|-----------------|-------------------------|-----------------------|--------------------------------|----------------------|--------------------------------|--------------------------------|---------------------------------------------------------------------|--------------|--------------------------------------------------|
| | | | | Full load 100% | 3/4 load 75% | 1/2 load 50% | | I _N A | I _S /I _N | T _N Nm | T _r /T _N | T _b /T _N | | | |
| 1000 r/min = 6 poles | | | | 400 V 50 Hz | | | | CENELEC-design | | | | | | | |
| 7.5 | M3AA 160MLA 6 | 3GAA163410-••K | 980 | 90,8 | 91,5 | 91,0 | 0,78 | 15,2 | 7,9 | 73,0 | 1,7 | 3,3 | 0,114 | 125 | 59 |
| 11 | M3AA 160MLB 6 | 3GAA163420-••K | 979 | 91,2 | 91,8 | 91,1 | 0,74 | 23,5 | 8,5 | 107 | 2,2 | 3,9 | 0,131 | 139 | 59 |
| 15 | M3AA 180MLA 6 | 3GAA183410-••K | 987 | 92,2 | 92,4 | 91,5 | 0,77 | 30,4 | 7,7 | 145 | 2,2 | 3,5 | 0,225 | 175 | 59 |
| 18.5 | M3AA 200MLA 6 | 3GAA203410-••K | 990 | 92,8 | 93,2 | 92,6 | 0,77 | 37,3 | 7,5 | 178 | 2,6 | 3,2 | 0,448 | 218 | 63 |
| 22 | M3AA 200MLB 6 | 3GAA203420-••K | 990 | 93,3 | 93,7 | 93,1 | 0,79 | 43,0 | 7,8 | 212 | 2,6 | 3,2 | 0,531 | 245 | 63 |
| 30 | M3AA 225SMA 6 | 3GAA223210-••K | 989 | 94,1 | 94,6 | 94,4 | 0,81 | 56,8 | 7,9 | 289 | 2,8 | 3,1 | 0,813 | 310 | 63 |
| 37 | M3AA 250SMA 6 | 3GAA253210-••K | 991 | 94,4 | 94,9 | 94,7 | 0,83 | 68,0 | 7,7 | 356 | 2,7 | 2,9 | 1,490 | 367 | 63 |

| Output kW | Motor type | Product code | Speed r/min | Efficiency IEC 60034-30-1; 2014 | | | Power factor Cosφ | Current | | Torque | | | Moment of inertia J = 1/4 GD ² kgm ² | Weight kg | Sound pressure Level L _{PA} dB |
|-----------------------------|---------------|----------------|----------------|------------------------------------|-----------------|-----------------|-------------------------|---------------------------|--------------------------------|----------------------|--------------------------------|--------------------------------|---------------------------------------------------------------------|--------------|--------------------------------------------------|
| | | | | Full load 100% | 3/4 load 75% | 1/2 load 50% | | I _N A | I _S /I _N | T _N Nm | T _r /T _N | T _b /T _N | | | |
| 1000 r/min = 6 poles | | | | 400 V 50 Hz | | | | High-output design | | | | | | | |
| 18.5 | M3AA 180MLB 6 | 3GAA183420-••K | 980 | 91,7 | 92,5 | 92,0 | 0,75 | 38,8 | 6,4 | 180 | 2,1 | 3,1 | 0,220 | 168 | 65 |
| 37 | M3AA 225SMB 6 | 3GAA223220-••K | 985 | 93,3 | 94,2 | 94,0 | 0,80 | 71,5 | 7,0 | 359 | 2,7 | 3,0 | 0,813 | 307 | 68 |
| 45 | M3AA 250SMB 6 | 3GAA253220-••K | 991 | 93,7 | 94,1 | 93,6 | 0,81 | 85,5 | 7,6 | 434 | 2,9 | 3,3 | 1,50 | 389 | 68 |
| 55 | M3AA 250SMC 6 | 3GAA253230-••K | 989 | 94,1 | 94,7 | 94,5 | 0,80 | 105 | 7,1 | 531 | 3,0 | 3,1 | 1,490 | 390 | 68 |

Note! For missing motor types on generation K list please refer to previous page (L generation data)

Variant codes

Aluminum motors

Variant codes specify additional options and features to the standard motor. The desired features are listed as three-digit variant codes in the motor order. Note also that there are variants that cannot be used together.

Most of the variant codes apply to IE2 and IE3 motors. However, confirm the availability of variants for IE3 motors with your ABB sales office before making an order. Variant codes for L generation motors on request!

| Code/Variants | Frame size | | | | | | | | | | | | |
|---------------------------------|----------------------------------------------------------------------------------|----|----|----|-----|-----|-----|-----|-----|-----|-----|-----|-----|
| | 63 | 71 | 80 | 90 | 100 | 112 | 132 | 160 | 180 | 200 | 225 | 250 | 280 |
| Balancing | | | | | | | | | | | | | |
| 423 | Balanced without key. | - | - | - | • | • | • | • | • | • | • | • | • |
| 424 | Full-key balancing | - | - | - | • | • | • | • | • | • | • | • | • |
| Bearings and Lubrication | | | | | | | | | | | | | |
| 036 | Transport lock for bearings. | - | - | - | • | • | • | • | • | • | • | • | • |
| 037 | Roller bearing at D-end. | - | - | - | • | • | • | • | • | • | • | • | • |
| 039 | Cold-resistant grease | • | • | • | • | • | • | - | - | - | - | - | - |
| 040 | Heat-resistant grease | • | • | • | • | • | • | - | - | - | - | - | - |
| 041 | Bearings regreasable via grease nipples. | - | - | - | • | • | • | • | • | • | • | • | ○ |
| 043 | SPM compatible nipples for vibration measurement | - | - | - | - | - | • | • | • | • | • | • | ○ |
| 057 | 2RS bearings at both ends. | • | • | • | • | • | • | • | • | • | • | • | • |
| 058 | Angular contact bearing at D-end, shaft force away from bearing. | - | - | - | • | • | • | • | • | • | • | • | • |
| 059 | Angular contact bearing at N-end, shaft force towards bearing. | - | - | - | • | • | • | • | • | • | • | • | • |
| 188 | 63-series bearing in D-end | - | - | - | ○ | • | ○ | • | ○ | ○ | ○ | ○ | ○ |
| 796 | Grease nipples JIS B 1575 PT 1/8 Type A | - | - | - | - | - | • | • | • | • | • | • | • |
| 797 | Stainless steel SPM nipples | - | - | - | - | - | • | • | • | • | • | • | • |
| 798 | Stainless steel grease nipples | - | - | - | - | - | • | • | • | • | • | • | • |
| Brakes | | | | | | | | | | | | | |
| 412 | Built-in brake. | - | - | - | - | - | - | • | • | - | - | - | - |
| Branch standard designs | | | | | | | | | | | | | |
| 071 | Cooling Tower duty | - | - | - | - | - | • | • | • | • | • | • | • |
| 142 | Manilla connection. | - | - | - | • | • | • | • | • | • | • | • | • |
| 178 | Stainless steel / acid proof bolts. | • | • | • | • | • | • | • | • | • | • | • | • |
| 209 | Non-standard voltage or frequency, (special winding). | - | - | - | • | • | • | • | • | • | • | • | • |
| 217 | Cast iron D-end shield (on aluminum motor). | - | - | - | • | • | • | • | ○ | ○ | ○ | ○ | ○ |
| 425 | Corrosion protected stator and rotor core. | • | • | • | • | • | • | • | • | • | • | • | • |
| 983 | Shock resistant design | - | - | - | - | - | - | - | - | • | • | • | - |
| Cooling system | | | | | | | | | | | | | |
| 053 | Metal fan cover. | - | • | • | • | • | • | • | ○ | ○ | ○ | ○ | ○ |
| 068 | Light alloy metal fan | - | • | • | • | • | • | • | • | • | • | • | • |
| 075 | Cooling method IC418 (without fan). | - | - | - | • | • | • | • | • | • | • | • | • |
| 183 | Separate motor cooling (fan axial, N-end). | - | • | • | • | • | • | • | • | • | • | • | • |
| 189 | Separate motor cooling, IP44, 400V, 50Hz (fan axial, N-end). | - | - | - | - | - | - | • | • | • | • | • | • |
| Documentation | | | | | | | | | | | | | |
| 141 | Binding 2D main dimension drawing. | - | • | • | • | • | • | • | • | • | • | • | • |
| Drain holes | | | | | | | | | | | | | |
| 065 | Plugged existing drain holes. | • | • | • | • | • | • | • | • | • | • | • | • |
| Earthing Bolt | | | | | | | | | | | | | |
| 067 | External earthing bolt. | • | • | • | • | • | • | • | • | • | • | • | • |
| Hazardous Environments | | | | | | | | | | | | | |
| 334 | Ex t, Dust group III B T125C Db, IP6X (non-conductive dust) acc. IEC/EN60079-31. | - | - | - | • | • | • | • | - | - | - | - | - |
| 335 | Ex t, Dust group III B T125C Dc, IP5X (non-conductive dust) acc. IEC/EN60079-31. | - | - | - | • | • | • | • | - | - | - | - | - |
| 336 | Ex t, Dust group III C T125 Db, IP6X (conductive dust) acc. IEC/EN60079-31. | - | - | - | • | • | • | • | - | - | - | - | - |
| 337 | Ex t, Dust group III C T125 Dc, IP6X (conductive dust) acc. IEC/EN60079-31. | - | - | - | • | • | • | • | - | - | - | - | - |
| 452 | DIP/Ex tD acc. to ATEX directive 94/9/EC, T= 125 °C, cat. 3D, IP55 | - | • | • | • | • | • | • | • | • | • | • | • |
| 454 | DIP/Ex tD acc. to ATEX directive 94/9/EC, T= 125 °C, cat. 3D, IP65 | - | - | - | - | - | - | • | - | - | - | - | - |
| 456 | Ex nA IIC T3 Gc acc. IEC/EN 60079-15 with certificates. | - | - | - | • | • | • | - | - | - | - | - | - |
| 480 | Ex nA II acc. to ATEX directive 94/9/EC, temp. class T3. | - | • | • | • | • | • | • | • | • | • | • | • |
| 804 | DIP/Ex tD, IEC 61241, T125 °C, IP55 (zone 22). | - | - | - | - | - | • | - | - | - | - | - | - |
| 805 | DIP/Ex tD, IEC 61241, T125 °C, IP65 (zone 21). | - | - | - | - | - | • | - | - | - | - | - | - |
| Heating elements | | | | | | | | | | | | | |
| 450 | Heating element, 100-120 V | - | - | • | • | • | • | • | • | • | • | • | • |
| 451 | Heating element, 200 - 240 V | - | • | • | • | • | • | • | • | • | • | • | • |
| Insulation system | | | | | | | | | | | | | |

○ = Included as standard | • = Available as option | - = Not applicable

| Code/Variants | Frame size | | | | | | | | | | | | |
|----------------------------------------------------------------------------------------------------------------------------------|------------|----|----|----|-----|-----|-----|-----|-----|-----|-----|-----|-----|
| | 63 | 71 | 80 | 90 | 100 | 112 | 132 | 160 | 180 | 200 | 225 | 250 | 280 |
| 014 Winding insulation class H. | - | - | - | • | • | • | • | • | • | • | • | • | • |
| 405 Special winding insulation for frequency converter supply. | - | - | - | • | • | • | • | • | • | • | • | • | • |
| 406 Winding insulation for supply > 690 <= 1000 volts | - | - | - | - | - | - | - | - | - | • | • | • | • |
| Marine | | | | | | | | | | | | | |
| 024 Fulfilling Bureau Veritas (BV) requirements, with certificate. | - | - | - | • | • | • | • | • | • | • | • | • | • |
| 025 Fulfilling Det Norske Veritas (DNV) requirements, with certificate. | • | • | • | • | • | • | • | • | • | • | • | • | • |
| 026 Fulfilling Lloyds Register of Shipping (LR) requirements, with certificate. | • | • | • | • | • | • | • | • | • | • | • | • | • |
| 027 Fulfilling American Bureau of Shipping (ABS) requirements, with certificate. | • | • | • | • | • | • | • | • | • | • | • | • | • |
| 049 Fulfilling Germanischer Lloyd (GL) requirements, with certificate. | • | • | • | • | • | • | • | • | • | • | • | • | • |
| 050 Fulfilling Registro Italiano Navale (RINA) requirements, with certificate. | - | • | • | • | • | • | • | • | • | • | • | • | • |
| 051 Fulfilling Russian Maritime Register of Shipping (RS) requirements, with certificate. | - | - | - | - | - | - | - | • | • | • | • | • | • |
| 096 Fulfilling Lloyds Register of Shipping (LR) requirements, without certificate (non-essential duty only) | • | • | • | • | • | • | • | • | • | • | • | • | • |
| 186 Fulfilling Det Norske Veritas (DNV) requirements, without certificate (non-essential duty only) | • | • | • | • | • | • | • | • | • | • | • | • | • |
| 481 Fulfilling Nippon Kaiji Kyokai (NK) requirements, with certificate. | - | - | - | • | • | • | • | • | • | • | • | • | • |
| 483 Fulfilling China Classification Societies (CCS) requirements (Beijing), with certificate. | - | - | - | • | • | • | • | • | • | • | • | • | • |
| 484 Fulfilling Korea Register of Shipping (KR) requirements, with certificate. | - | - | - | • | • | • | • | • | • | • | • | • | • |
| 491 Fulfilling Nippon Kaiji Kyokai (NK) requirements, without certificate. | - | • | • | • | • | • | • | • | • | • | • | • | • |
| 492 Fulfilling Registro Italiano Navale (RINA) requirements, without certificate. | • | • | • | • | • | • | • | • | • | • | • | • | • |
| 493 Fulfilling China Classification Societies (CCS) requirements (Beijing), without certificate. | • | • | • | • | • | • | • | • | • | • | • | • | • |
| 494 Fulfilling Korea Register of Shipping (KR) requirements, without certificate. | - | • | • | • | • | • | • | • | • | • | • | • | • |
| 496 Fulfilling Bureau Veritas (BV) requirements, without certificate(non-essential duty only) | • | • | • | • | • | • | • | • | • | • | • | • | • |
| 497 Fulfilling Russian Maritime Register of Shipping (RS) requirements, without certificate. | - | - | - | - | - | - | - | • | • | • | • | • | • |
| 675 Fulfilling American Bureau of Shipping (ABS) requirements, without certificate (non-essential duty only) | • | • | • | • | • | • | • | • | • | • | • | • | • |
| 676 Fulfilling Germanischer Lloyd (GL) requirements, without certificate (non-essential duty only) | - | - | - | • | • | • | • | • | • | • | • | • | • |
| Mounting arrangements | | | | | | | | | | | | | |
| 007 IM 3001 flange mounted, IEC flange, from IM 1001 (B5 from B3). | - | - | - | - | - | - | - | • | • | • | • | • | • |
| 008 IM 2101 foot/flange mounted, IEC flange, from IM 1001 (B34 from B3). | • | • | • | • | • | • | • | • | - | - | - | - | - |
| 009 IM 2001 foot/flange mounted, IEC flange, from IM 1001 (B35 from B3). | • | • | • | • | • | • | • | • | • | • | • | • | • |
| 047 IM 3601 flange mounted, IEC flange, from IM 3001 (B14 from B5). | • | • | • | • | • | • | • | • | • | - | - | - | - |
| 048 IM 3001 flange mounted, IEC flange, from IM 3601 (B5 from B14). | - | • | • | • | • | • | • | - | - | - | - | - | - |
| 066 Modified for specified mounting position differing from IM B3 (1001), IM B5 (3001), B14 (3601), IM B35 (2001), IM B34 (2101) | • | • | • | • | • | • | • | • | • | • | • | • | • |
| 200 Flange ring holder. | - | • | • | • | • | • | • | - | - | - | - | - | - |
| 218 Flange ring FT 85. | - | • | • | - | • | - | - | - | - | - | - | - | - |
| 219 Flange ring FT 100. | - | • | • | - | • | - | - | - | - | - | - | - | - |
| 220 Flange ring FF 100. | - | • | • | - | • | - | - | - | - | - | - | - | - |
| 223 Flange ring FF 115. | - | • | • | - | • | - | - | - | - | - | - | - | - |
| 224 Flange ring FT 115. | - | • | • | - | • | - | - | - | - | - | - | - | - |
| 226 Flange ring FF 130. | - | • | • | • | • | - | - | - | - | - | - | - | - |
| 227 Flange ring FT 130. | - | • | • | • | • | - | - | - | - | - | - | - | - |
| 229 Flange FT 130. | - | - | - | • | - | • | - | - | - | - | - | - | - |
| 233 Flange ring FF 165. | - | - | • | • | • | • | - | - | - | - | - | - | - |
| 234 Flange ring FT 165. | - | • | • | • | • | • | - | - | - | - | - | - | - |
| 235 Flange FF 165. | - | - | - | - | • | - | - | - | - | - | - | - | - |
| 236 Flange FT 165. | - | - | - | - | - | • | - | - | - | - | - | - | - |
| 243 Flange ring FF 215. | - | - | - | - | - | • | - | - | - | - | - | - | - |
| 244 Flange ring FT 215. | - | - | - | - | - | • | - | - | - | - | - | - | - |
| 245 Flange FF 215. | - | - | - | • | - | • | - | - | - | - | - | - | - |
| 253 Flange ring FF 265. | - | - | - | - | - | • | - | - | - | - | - | - | - |
| 254 Flange ring FT 265. | - | - | - | - | - | • | - | - | - | - | - | - | - |
| 255 Flange FF 265. | - | - | - | - | - | - | • | - | - | - | - | - | - |
| 260 Flange FT 115. | - | - | - | - | • | - | - | - | - | - | - | - | - |
| Painting | | | | | | | | | | | | | |
| 114 Special paint color, standard grade | • | • | • | • | • | • | • | • | • | • | • | • | • |
| Protection | | | | | | | | | | | | | |
| 005 Protective roof, vertical motor, shaft down. | - | • | • | • | • | • | • | • | • | • | • | • | • |
| 072 Radial seal at D-end. Not possible for 2-pole , 280 and 315 frames | - | • | • | • | • | • | • | • | • | • | • | • | • |
| 158 Degree of protection IP65. | - | • | • | • | • | • | • | • | • | • | • | • | • |
| 211 Weather protected, IP xx W | - | • | • | • | • | • | • | • | • | • | • | • | • |
| 403 Degree of protection IP56. | • | • | • | • | • | • | • | • | • | • | • | • | • |
| 404 Degree of protection IP56, without fan and fan cover. | - | - | - | • | • | • | - | - | - | - | - | - | - |

○ = Included as standard | • = Available as option | - = Not applicable

| Code/Variants | Frame size | | | | | | | | | | | | |
|---------------------------------------------------------------------------------------------------------|------------|----|----|----|-----|-----|-----|-----|-----|-----|-----|-----|-----|
| | 63 | 71 | 80 | 90 | 100 | 112 | 132 | 160 | 180 | 200 | 225 | 250 | 280 |
| 784 Gamma-seal at D-end. | - | - | - | • | • | • | • | • | • | • | • | • | • |
| Rating & instruction plates | | | | | | | | | | | | | |
| 002 Restamping voltage, frequency and output, continuous duty. | • | • | • | • | • | • | • | • | • | • | • | • | • |
| 004 Additional text on std rating plate (max 12 digits on free text line). | - | - | - | • | • | • | • | • | • | • | • | • | • |
| 095 Restamping output (maintained voltage, frequency), intermittent duty. | • | • | • | • | • | • | • | • | • | • | • | • | • |
| 098 Stainless rating plate. | - | • | • | • | • | • | • | • | • | • | • | • | • |
| 126 Tag plate | - | - | - | • | • | • | • | • | • | • | • | • | • |
| 135 Mounting of additional identification plate, stainless. | - | • | • | • | • | • | • | • | • | • | • | • | - |
| 138 Mounting of additional identification plate, aluminium. | • | • | • | • | • | • | • | • | • | • | • | • | • |
| 139 Additional identification plate delivered loose. | - | • | • | • | • | • | • | • | • | • | • | • | • |
| 159 Additional plate with text "Made in" | • | • | • | • | • | • | • | • | • | • | • | • | • |
| 160 Additional rating plate affixed. | - | - | - | • | • | • | • | • | • | • | • | • | • |
| 161 Additional rating plate delivered loose. | • | • | • | • | • | • | • | • | • | • | • | • | • |
| 163 Frequency converter rating plate. Rating data according to quotation. | - | - | - | • | • | • | • | • | • | • | • | • | • |
| 270 Additional rating plate with standard data, delivered loose | - | • | • | • | • | • | • | • | • | • | • | • | • |
| 332 Baldor Catalogue # | • | • | • | • | • | • | • | • | • | • | • | • | • |
| 333 Not for use in the USA | • | • | • | • | • | • | • | • | • | • | • | • | • |
| Shaft & rotor | | | | | | | | | | | | | |
| 069 Two shaft extensions according to catalog drawings. | - | - | - | • | • | • | • | • | • | • | • | • | • |
| 070 Special shaft extension at D-End, standard shaft material | - | - | - | • | • | • | • | - | - | - | - | - | - |
| 131 Motor delivered with half key (key not exceeding shaft diameter) | - | - | - | • | • | • | • | • | • | • | • | • | • |
| 165 Shaft extension with open keyway | - | - | - | • | • | • | • | • | • | • | • | • | • |
| 410 Shaft material stainless steel | - | - | - | • | • | • | - | - | - | - | - | - | - |
| 591 Special shaft extension according to customer specification. | - | - | - | • | • | • | • | • | • | • | • | • | • |
| 600 Special shaft extension at N-end, standard shaft material. | - | - | - | • | • | • | • | - | - | - | - | - | - |
| Standards and Regulations | | | | | | | | | | | | | |
| 010 Fulfilling CSA Safety Certificate. | - | - | - | - | - | - | - | • | • | • | • | • | • |
| 242 Fulfilling CSA Energy Efficiency Verification IE2 (code 010 included) | - | - | - | - | - | - | - | • | • | • | • | • | • |
| 331 IE1 motor not for sale for use in EU | - | • | • | • | • | • | • | • | • | • | • | • | • |
| 408 Fulfilling EISA Subtype II efficiency requirements, CC031A. | - | - | - | - | - | - | - | • | • | • | • | • | • |
| 540 China energy label | - | - | - | • | • | • | • | • | • | • | • | • | • |
| 542 NBR design | - | - | - | • | • | • | • | • | • | • | • | • | • |
| 543 Australian MEPS | - | - | - | • | • | • | • | • | • | • | • | • | - |
| 548 Certificate of conformity according TR-CU 004/2011 for customs union RU, KZ, BY. | - | - | - | • | • | • | • | • | • | • | • | • | • |
| 822 WIMES 3.03i6 Compliant Design for DOL operation | - | - | - | • | • | • | • | - | - | - | - | - | - |
| 823 WIMES 3.03i6 Compliant Design for VSD operation | - | - | - | • | • | • | • | • | • | - | - | - | - |
| Stator winding temperature sensors | | | | | | | | | | | | | |
| 121 Bimetal detectors, break type (NCC), (3 in series), 130 °C, in stator winding | • | • | • | • | • | • | • | • | • | • | • | • | • |
| 122 Bimetal detectors, break type (NCC), (3 in series), 150 °C, in stator winding | - | • | • | • | • | • | • | • | • | • | • | • | • |
| 123 Bimetal detectors, break type (NCC), (3 in series), 170 °C, in stator winding | • | • | • | • | • | • | • | • | • | • | • | • | • |
| 124 Bimetal detectors, break type (NCC), (3 in series), 140 °C, in stator winding | - | - | - | - | - | - | - | • | • | • | • | • | • |
| 125 Bimetal detectors, break type (NCC), (2x3 in series), 150 °C, in stator winding | - | - | • | • | • | • | • | • | • | • | • | • | • |
| 127 Bimetal detectors, break type (NCC), (3 in series, 130 °C & 3 in series, 150 °C), in stator winding | - | - | • | • | • | • | • | • | • | • | • | • | • |
| 321 Bimetal detectors, closing type (NO), (3 in parallel), 130°C, in stator winding. | - | - | - | • | • | • | • | - | - | - | - | - | - |
| 322 Bimetal detectors, closing type (NO), (3 in parallel), 150°C, in stator winding. | - | - | - | • | • | • | • | - | - | - | - | - | - |
| 435 PTC - thermistors (3 in series), 130 °C, in stator winding | • | • | • | • | • | • | • | • | • | • | • | • | • |
| 436 PTC - thermistors (3 in series), 150 °C, in stator winding | • | • | • | • | • | • | • | ○ | ○ | ○ | ○ | ○ | ○ |
| 437 PTC - thermistors (3 in series), 170 °C, in stator winding | - | - | - | • | • | • | • | • | • | • | • | • | • |
| 439 PTC - thermistors (2x3 in series), 150 °C, in stator winding | • | • | • | • | • | • | • | • | • | • | • | • | • |
| 440 PTC - thermistors (3 in series, 110°C & 3 in series, 130°C), in stator winding. | - | - | - | • | • | • | • | - | - | - | - | - | - |
| 441 PTC - thermistors (3 in series, 130 °C & 3 in series, 150 °C), in stator winding | • | • | • | • | • | • | • | • | • | • | • | • | • |
| 442 PTC - thermistors (3 in series, 150 °C & 3 in series, 170 °C), in stator winding | - | - | - | • | • | • | • | • | • | • | • | • | • |
| 445 Pt100 2-wire in stator winding, 1 per phase | - | - | - | • | • | • | • | • | • | • | • | • | • |
| 446 Pt100 2-wire in stator winding, 2 per phase | - | - | - | - | - | - | - | • | • | • | • | • | • |
| Terminal box | | | | | | | | | | | | | |
| 015 Motor supplied in D connection. | - | • | • | • | • | • | • | • | • | • | • | • | • |
| 016 9 terminals in terminal box | - | - | - | • | • | • | • | - | - | - | - | - | - |
| 017 Motor supplied in Y connection. | - | - | - | • | • | • | • | • | • | • | • | • | • |
| 019 Larger than standard terminal box. | - | - | - | - | - | - | - | - | • | • | • | • | • |
| 021 Terminal box LHS (seen from D-end). | - | - | - | - | - | - | - | - | • | • | • | • | • |
| 180 Terminal box RHS (seen from D-end). | - | - | - | - | - | - | - | - | • | • | • | • | • |
| 230 Standard metal cable gland. | - | • | • | • | • | • | • | • | • | • | • | • | • |
| 375 Standard plastic cable gland | - | • | • | • | • | • | • | - | - | - | - | - | - |
| 376 Two standard plastic cable glands | - | - | - | • | • | • | • | - | - | - | - | - | - |
| 418 Separate terminal box for auxiliaries, standard material. | - | - | - | - | - | • | • | • | • | • | • | • | • |

○ = Included as standard | • = Available as option | - = Not applicable

| Code/Variants | Frame size | | | | | | | | | | | | |
|---------------------------------------------------------------------------------------------------------------------|------------|----|----|----|-----|-----|-----|-----|-----|-----|-----|-----|-----|
| | 63 | 71 | 80 | 90 | 100 | 112 | 132 | 160 | 180 | 200 | 225 | 250 | 280 |
| 467 Lower than standard terminal box and rubber extended cable. Cable length 2 m | - | - | - | - | - | • | • | • | • | • | • | • | • |
| 729 Aluminum non-drilled flange for cable glands | - | - | - | - | - | - | - | - | - | • | • | • | • |
| 731 Two standard metal cable glands. | - | • | • | • | • | • | • | • | • | • | • | • | • |
| 740 Prepared for PG cable glands. | - | - | - | - | - | - | - | • | • | • | • | • | • |
| Testing | | | | | | | | | | | | | |
| 140 Test confirmation. | - | - | - | - | - | - | - | • | • | • | • | • | • |
| 145 Type test report from a catalogue motor; 400V 50Hz. | - | • | • | • | • | • | • | • | • | • | • | • | • |
| 146 Type test with report for one motor from specific delivery batch. | - | - | - | • | • | • | • | • | • | • | • | • | • |
| 147 Type test with report for motor from specific delivery batch, customer witnessed. | - | - | - | • | • | • | • | • | • | • | • | • | • |
| 148 Routine test report. | • | • | • | • | • | • | • | • | • | • | • | • | • |
| 153 Reduced test for classification society. | - | - | - | • | • | • | • | • | • | • | • | • | • |
| 221 Type test and multi-point load test with report for one motor from specific delivery batch. | - | - | - | • | • | • | • | • | • | • | • | • | • |
| 222 Torque/speed curve, type test and multi-point load test with report for one motor from specific delivery batch. | - | - | - | • | • | • | • | • | • | • | • | • | • |
| 760 Vibration level test | - | - | - | • | • | • | • | • | • | • | • | • | • |
| 762 Noise level test for one motor from specific delivery batch. | - | - | - | • | • | • | • | • | • | • | • | • | • |
| Variable speed drives | | | | | | | | | | | | | |
| 470 Prepared for hollow shaft pulse tacho (L&L equivalent). | - | - | - | - | - | - | - | • | • | • | • | • | • |
| 472 1024 pulse tacho (L&L 861007455-1024). | - | - | - | - | - | - | - | • | • | • | • | • | • |
| 473 2048 pulse tacho (L&L 861007455-2048). | - | - | - | - | - | - | - | • | • | • | • | • | • |
| 474 Separate motor cooling (axial fan, N-end) and prepared for hollow shaft tacho (L&L equivalent) | - | - | - | - | - | - | - | • | • | • | • | • | • |
| 476 Separate motor cooling (axial fan, N-end) and 1024 pulse tacho (L&L 861007455-1024) | - | - | - | - | - | - | - | • | • | • | • | • | • |
| 477 Separate motor cooling (axial fan, N-end) and 2048 pulse tacho (L&L 861007455-2048) | - | - | - | - | - | - | - | • | • | • | • | • | • |
| 570 Prepared for hollow shaft pulse tacho (L&L 503). | - | - | - | - | - | - | - | • | • | • | • | • | • |
| 572 1024 pulse tacho (L&L 503). | - | - | - | - | - | - | - | • | • | • | • | • | • |
| 573 2048 pulse tacho (L&L 503). | - | - | - | - | - | - | - | • | • | • | • | • | • |
| 574 Separate motor cooling (fan axial, N-end) and prepared for hollow shaft tacho (L&L 503). | - | - | - | - | - | - | - | • | • | • | • | • | • |
| 576 Separate motor cooling (fan axial, N-end) and 1024 pulse tacho (L&L 503). | - | - | - | - | - | - | - | • | • | • | • | • | • |
| 577 Separate motor cooling (fan axial, N-end) and 2048 pulse tacho (L&L 503). | - | - | - | - | - | - | - | • | • | • | • | • | • |
| 580 Separate motor cooling, IP44, 400 V, 50Hz (axial fan, N-end) and 1024 pulse tacho (L&L 503) | - | - | - | - | - | - | - | • | • | • | • | • | • |
| 581 Separate motor cooling, IP44, 400V, 50Hz (fan axial, N-end) and 2048 pulse tacho (L&L 503). | - | - | - | - | - | - | - | • | • | • | • | • | • |
| 661 1024 Pulse tacho mounted, Hohner series 59, 11-30V | - | - | - | • | • | • | • | - | - | - | - | - | - |
| 662 2048 Pulse tacho mounted, Hohner series 59, 11-30V | - | - | - | • | • | • | • | - | - | - | - | - | - |
| 701 Insulated bearing at N-end. | - | - | - | - | - | - | - | • | • | • | • | • | • |
| 704 EMC cable entry. | - | - | - | • | • | • | • | • | • | • | • | • | • |

○ = Included as standard | • = Available as option | - = Not applicable

Mechanical design

Motor frame and drain holes

Motor frame

The motor frame is made of aluminum alloy. Frame sizes 63 to 180 have aluminum feet and sizes 200 to 280 have cast iron feet.

The bearing end shields of sizes 63 to 132 are made of aluminum, and those of 160 to 280 are made of cast iron.

Drain holes

Motors that will be operated in very humid or wet environments and especially under intermittent duty should be provided with drain holes. The IM designation, such as IM 3031, determines the intended mounting arrangement for the motor.

Motors are provided with closable plastic plugs in the drain holes. The plugs on delivery, when mounting the motors, ensure that the drainholes face downwards. In the case of vertical mounting, the upper plug must be hammered home completely. In very dusty environments both plugs should be hammered home.

Motors are supplied with drain holes both at the D-end and N-end.

When mounting arrangement differs from foot mounted IM B3, please use variant code 066 when ordering. See variant codes 065, 066 and 076 under the heading "Drain holes".

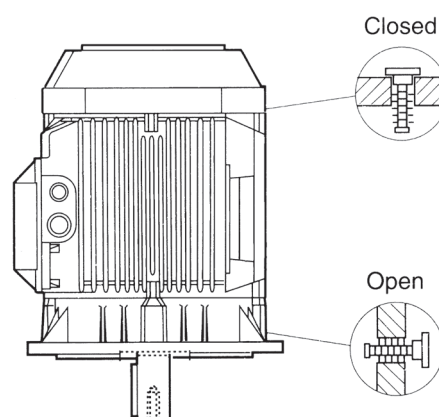
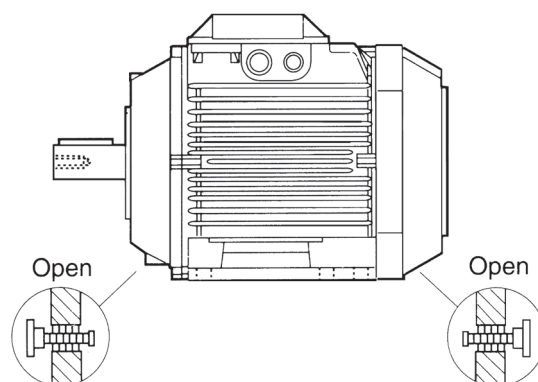

Bearings

The motors are provided with bearings according to the tables below.

Greater axial forces can be tolerated if the motors are provided with angular contact ball bearings.

Standard design: deep groove ball bearings

| Foot- and flange-mounted motor | | | |
|--------------------------------|----------|------------|------------|
| Motor size | | D-end | N-end |
| 63 | | 6202-2Z/C3 | 6201-2Z/C3 |
| 71 | | 6203-2Z/C3 | 6202-2Z/C3 |
| 80 | | 6204-2Z/C3 | 6203-2Z/C3 |
| 90 | | 6205-2Z/C3 | 6204-2Z/C3 |
| 100 | | 6306-2Z/C3 | 6205-2Z/C3 |
| 112 ¹⁾ | | 6306-2Z/C3 | 6205-2Z/C3 |
| 112 ²⁾ | | 6206-2Z/C3 | 6205-2Z/C3 |
| 132 ³⁾ | | 6208-2Z/C3 | 6206-2Z/C3 |
| 132 ⁴⁾ | | 6308-2Z/C3 | 6206-2Z/C3 |
| 160 | | 6309-2Z/C3 | 6209-2Z/C3 |
| 180 | | 6310-2Z/C3 | 6209-2Z/C3 |
| 200 | | 6312-2Z/C3 | 6210-2Z/C3 |
| 225 | | 6313-2Z/C3 | 6212-2Z/C3 |
| 250 | | 6315-2Z/C3 | 6213-2Z/C3 |
| 280 | 2 pole | 6315/C3 | 6213/C3 |
| 280 | 4-8 pole | 6316/C3 | 6213/C3 |

¹⁾all types except²⁾112 J-gen

³⁾all types except⁴⁾SM_

Note that in such cases the axial force must only operate in one direction.

Motor versions with roller bearings tolerate greater radial forces.

Alternative design with roller bearings

It is recommended to use roller bearings in belt drives for motor sizes 160 to 280.

See variant code 037 under the heading “Bearings and lubrication”.

| Foot- and flange-mounted motor | | | |
|--------------------------------|----------|------------|------------|
| Motor size | | D-end | N-end |
| 63 | | - | 6201-2Z/C3 |
| 71 | | - | 6202-2Z/C3 |
| 80 | | - | 6203-2Z/C3 |
| 90 | | NU 205 | 6204-2Z/C3 |
| 100 | | NU 306 | 6205-2Z/C3 |
| 112 ¹⁾ | | NU 306 | 6205-2Z/C3 |
| 112 ²⁾ | | NU 206 | 6205-2Z/C3 |
| 132 ³⁾ | | NU 208 | 6206-2Z/C3 |
| 132 ⁴⁾ | | NU 308 | 6206-2Z/C3 |
| 160 | | NU 309 ECP | 6209-2Z/C3 |
| 180 | | NU 310 ECP | 6209-2Z/C3 |
| 200 | | NU 312 ECP | 6210-2Z/C3 |
| 225 | | NU 313 ECP | 6212-2Z/C3 |
| 250 | | NU 315 ECP | 6213-2Z/C3 |
| 280 | 2 pole | NU 315 ECP | 6213/C3 |
| 280 | 4-8 pole | NU 316 ECP | 6213/C3 |

¹⁾all types except²⁾112 J-gen

³⁾all types except⁴⁾SM_

Alternative design: angular contact ball bearings

See variant codes 058 and 059 under the heading “Bearings and lubrication”.

| Motor size | | D-end | N-end |
|-------------------|----------|----------|----------|
| | | 058 | 059 |
| 63 | | - | - |
| 71 | | - | - |
| 80 | | - | - |
| 90 | | 7205 B | 7204 B |
| 100 | | 7306 B | 7205 B |
| 112 ¹⁾ | | 7306 B | 7205 B |
| 112 ²⁾ | | 7206 B | 7205 B |
| 132 ³⁾ | | 7208 B | 7206 B |
| 132 ⁴⁾ | | 7308 B | 7206 B |
| 160 | | 7309 BEP | 7209 BEP |
| 180 | | 7310 BEP | 7209 BEP |
| 200 | | 7312 BEP | 7210 BEP |
| 225 | | 7313 BEP | 7212 BEP |
| 250 | | 7315 BEP | 7213 BEP |
| 280 | 2 pole | 7315 BEP | 7213 BEP |
| 280 | 4-8 pole | 7316 BEP | 7213 BEP |

¹⁾all types except²⁾112 J-gen

³⁾all types except⁴⁾SM_

Transport locking

Motors provided with roller bearings or angular contact ball bearings are fitted with a transport lock to prevent damage to the bearings, due to vibration, during transport.

Axially locked bearings

The table below shows which of the motor's bearings are axially locked in the bearing seat. In motor size 63 the locking is done by an internal retaining ring, in motor sizes 71 to 280 by an inner bearing cover.

| Motor size | Foot-mounted motors | Flange-mounted motors | |
|------------|---------------------|-----------------------|---------------------|
| | | Large flange | Small flange |
| 63 | On request at D-end | On request at D-end | On request at D-end |
| 71-132 | D-end ¹⁾ | D-end 1) | D-end 1) |
| 160-280 | D-end | D-end | - |

¹⁾A spring-washer at the N-end presses the rotor toward the D-end.

Bearing seals

| Motor size | Number of poles | Standard design, axial seal | | Alternative design Radial seal (Din3760) Variant code 073 |
|------------|-----------------|-----------------------------|----------------|-----------------------------------------------------------------|
| | | D-end | N-end | |
| 71 | 2-12 | V-16A | Labyrinth seal | 17x28x7 |
| 80 | 2-12 | V-20A | Labyrinth seal | 20x40x7 |
| 90 | 2-12 | V-25A | Labyrinth seal | 25x42x7 |
| 100 | 2-12 | V-30A | Labyrinth seal | 30x47x7 |
| 112 | 2-12 | V-30A | Labyrinth seal | 30x47x7 |
| 132 | 2-12 | V-40A | Labyrinth seal | 40x62x7 |
| 160 | 2-12 | V-45A | V-45A | 45x65x8 |
| 180 | 2-12 | V-50A | V-45A | 50x72x8 |
| 200 | 2-12 | V-60A | V-50A | 60x80x8 |
| 225 | 2-12 | V-65A | V-60A | 65x85x8 |
| 250 | 2-12 | V-75A | V-65A | 75x95x8 |

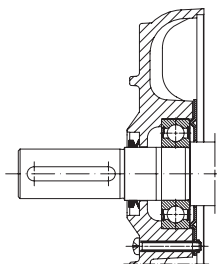

Motor sizes 71 - 132

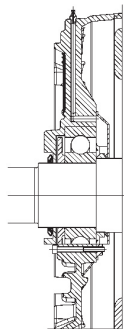

Motor sizes 160 - 250

Bearing life and lubrication

Bearing life

The nominal life is defined as the number of hours that are attained or exceeded by 90 percent of identical bearings, in a large test series, under certain specified conditions. 50 percent of the bearings attain a life of as much as 5 times this figure.

The life of bearings is dependent on various factors such as bearing load, motor speed, operating temperature and the purity of the grease. The permissible radial and axial loading for different motor sizes is shown in the table on the following pages.

The table is valid for 50 Hz. For 60 Hz and/or some other bearing life than specified in the table the values are changed according to the table below.

The table values assume the occurrence of only radial or axial forces. In the case of simultaneous radial and axial forces information can be supplied on request. It is assumed that the radial force is applied at the end of the motor shaft.

Permissible force at changed bearing life or supply frequency

| Bearing life in hours at | | |
|--------------------------|--------|---------------------------------|
| 50 Hz | 60 Hz | |
| 25 000 | 21 000 | 100 % of value for 25.000 hours |
| 40 000 | 33 000 | 100 % of value for 40.000 hours |
| 63 000 | 52 000 | 86 % of value for 40.000 hours |
| 80 000 | 67 000 | 80 % of value for 40.000 hours |

Lubrication

The motors are delivered with bearing grease for use at normal temperatures in dry or humid environments. The motors are lubricated for ambient temperatures 40°C and in other temperatures above 40°C, see table next page.

Motor sizes 63 to 250 are provided with shielded bearings. As an option, motor sizes 90 to 250 are provided with grease nipples for regreasing, see variant code 041 under the heading "Bearings and lubrications".

Motor size 280 is provided with grease nipples for re-greasing as standard.

The lubrication interval L_1 , suitable for relubricated bearings, is defined as the number of operating hours after which 99 percent of the bearings are adequately lubricated.

Lubrication intervals and grease quantities are specified on a plate on the motor as well as in the manual supplied with the motor.

The grease lifetime L_{10} , suitable for permanent lubricated bearings, is defined as the number of operating hours after which 90 percent of the bearings are adequately lubricated. 50 percent of the bearings achieve two times this figure. Maximum lifetime, however, should be regarded as 40,000 hours.

In case of high ambient temperatures the shaft loads must be reduced compared to permissible loadings in the table, please contact ABB.

Lubrication intervals

ABB follows the L_1 -principle in defining lubrication interval. That means that 99 percent of the motors are sure to make the interval time. The lubrication intervals can also be calculated according to the L_{10} -principle, which are normally doubled compared to L_1 -values. Values available from ABB at request.

The table below gives lubrication intervals according to the L_1 -principle for different speeds. The values are valid for horizontal mounted motors (B3), with about 80°C bearing temperature and using good quality grease with lithium complex soap and with mineral or PAO-oil.

For more information, see ABB's Low Voltage Motors Manual.

Lubrication intervals for ball and roller bearings

| Frame size | Amount of grease g | Amount of grease | | | | | |
|------------------------------------------------------|--------------------|------------------|------------|------------|------------|------------|---------------|
| | | 3600 r/min | 3000 r/min | 1800 r/min | 1500 r/min | 1000 r/min | 500-750 r/min |
| Ball bearings: lubrication intervals in duty hours | | | | | | | |
| 280 | 60 | 2000 | 3500 | - | - | - | - |
| 280 | 70 | - | - | 8000 | 10 500 | 14 000 | 17 000 |
| Roller bearings: lubrication intervals in duty hours | | | | | | | |
| 280 | 60 | 1000 | 1750 | - | - | - | - |
| 280 | 70 | - | - | 4000 | 5250 | 7000 | 8500 |

Grease lifetime

In vertically mounted motors, the grease lifetime is half the figures as in following table. For applications corresponding to the empty cells in the table, please contact ABB. These applications can imply reduced lifetime for bearings and winding. Motors with roller bearings (optional) have considerably shorter grease life. For continuous operation regreasing nipples should be considered.

Grease lifetime

Ambient temperature and rated output

| | | 25 °C | | 40 °C | | 50 °C | | 60 °C | | 70 °C | | 80 °C | |
|-------------------|-------|--------|--------|--------|--------|--------|--------|--------|--------|--------|--------|--------|--------|
| Motor | r/min | Basic | High | Basic | High | Basic | High | Basic | High | Basic | High | Basic | High |
| 63 | 3000 | 40 000 | 40 000 | 40 000 | 40 000 | 40 000 | 40 000 | 31 000 | 31 000 | 17 000 | 17 000 | 9000 | 9000 |
| | 1500 | 40 000 | 40 000 | 40 000 | 40 000 | 40 000 | 40 000 | 33 000 | 33 000 | 18 000 | 18 000 | 9000 | 9000 |
| | 1000 | 40 000 | 40 000 | 40 000 | 40 000 | 40 000 | 40 000 | 33 000 | 33 000 | 18 000 | 18 000 | 9000 | 9000 |
| | 750 | 40 000 | 40 000 | 40 000 | 40 000 | 40 000 | 40 000 | 33 000 | 33 000 | 18 000 | 18 000 | 9000 | 9000 |
| 71 | 3000 | 40 000 | 40 000 | 40 000 | 40 000 | 40 000 | 40 000 | 27 000 | 27 000 | 15 000 | 15 000 | 8000 | 8000 |
| | 1500 | 40 000 | 40 000 | 40 000 | 40 000 | 40 000 | 40 000 | 33 000 | 33 000 | 18 000 | 18 000 | 9000 | 9000 |
| | 1000 | 40 000 | 40 000 | 40 000 | 40 000 | 40 000 | 40 000 | 33 000 | 33 000 | 18 000 | 18 000 | 9000 | 9000 |
| | 750 | 40 000 | 40 000 | 40 000 | 40 000 | 40 000 | 40 000 | 33 000 | 33 000 | 18 000 | 18 000 | 9000 | 9000 |
| 80 | 3000 | 40 000 | 40 000 | 40 000 | 40 000 | 39 000 | 39 000 | 23 000 | 23 000 | 13 000 | 13 000 | 7000 | 7000 |
| | 1500 | 40 000 | 40 000 | 40 000 | 40 000 | 40 000 | 40 000 | 33 000 | 33 000 | 18 000 | 18 000 | 9000 | 9000 |
| | 1000 | 40 000 | 40 000 | 40 000 | 40 000 | 40 000 | 40 000 | 33 000 | 33 000 | 18 000 | 18 000 | 9000 | 9000 |
| | 750 | 40 000 | 40 000 | 40 000 | 40 000 | 40 000 | 40 000 | 33 000 | 33 000 | 18 000 | 18 000 | 9000 | 9000 |
| 90 | 3000 | 40 000 | 40 000 | 40 000 | 40 000 | 33 000 | 33 000 | 20 000 | 20 000 | 11 000 | 11 000 | 6000 | 6000 |
| | 1500 | 40 000 | 40 000 | 40 000 | 40 000 | 40 000 | 40 000 | 33 000 | 33 000 | 18 000 | 18 000 | 9000 | 9000 |
| | 1000 | 40 000 | 40 000 | 40 000 | 40 000 | 40 000 | 40 000 | 33 000 | 33 000 | 18 000 | 18 000 | 9000 | 9000 |
| | 750 | 40 000 | 40 000 | 40 000 | 40 000 | 40 000 | 40 000 | 33 000 | 33 000 | 18 000 | 18 000 | 9000 | 9000 |
| 100 | 3000 | 40 000 | 40 000 | 39 000 | 39 000 | 25 000 | 25 000 | 15 000 | 15 000 | 8000 | 8000 | 4000 | 4000 |
| | 1500 | 40 000 | 40 000 | 40 000 | 40 000 | 40 000 | 40 000 | 30 000 | 30 000 | 17 000 | 17 000 | 9000 | 9000 |
| | 1000 | 40 000 | 40 000 | 40 000 | 40 000 | 40 000 | 40 000 | 33 000 | 33 000 | 18 000 | 18 000 | 9000 | 9000 |
| | 750 | 40 000 | 40 000 | 40 000 | 40 000 | 40 000 | 40 000 | 33 000 | 33 000 | 18 000 | 18 000 | 9000 | 9000 |
| 112 ¹⁾ | 3000 | 40 000 | 40 000 | 39 000 | 39 000 | 25 000 | 25 000 | 15 000 | 15 000 | 8000 | 8000 | 4000 | 4000 |
| | 1500 | 40 000 | 40 000 | 40 000 | 40 000 | 40 000 | 40 000 | 30 000 | 30 000 | 17 000 | 17 000 | 9000 | 9000 |
| | 1000 | 40 000 | 40 000 | 40 000 | 40 000 | 40 000 | 40 000 | 33 000 | 33 000 | 18 000 | 18 000 | 9000 | 9000 |
| | 750 | 40 000 | 40 000 | 40 000 | 40 000 | 40 000 | 40 000 | 33 000 | 33 000 | 18 000 | 18 000 | 9000 | 9000 |
| 112 ²⁾ | 3000 | 40 000 | 40 000 | 40 000 | 40 000 | 40 000 | 30 000 | 26 000 | 17 000 | | | | |
| | 1500 | 40 000 | 40 000 | 40 000 | 40 000 | 40 000 | | 27 000 | | | | | |
| | 1000 | 40 000 | 40 000 | 40 000 | 35 000 | 40 000 | | 40 000 | | | | | |
| | 750 | 40 000 | 40 000 | 40 000 | 35 000 | 40 000 | | 40 000 | | | | | |
| 132 ³⁾ | 3000 | 40 000 | 40 000 | 33 000 | 33 000 | 21 000 | 21 000 | 13 000 | 13 000 | 7000 | 7000 | 4000 | 4000 |
| | 1500 | 40 000 | 40 000 | 40 000 | 40 000 | 40 000 | 40 000 | 26 000 | 26 000 | 14 000 | 14 000 | 7000 | 7000 |
| | 1000 | 40 000 | 40 000 | 40 000 | 40 000 | 40 000 | 40 000 | 33 000 | 33 000 | 18 000 | 18 000 | 9000 | 9000 |
| | 750 | 40 000 | 40 000 | 40 000 | 40 000 | 40 000 | 40 000 | 33 000 | 33 000 | 18 000 | 18 000 | 9000 | 9000 |
| 132 ⁴⁾ | 3000 | 40 000 | 40 000 | 31 000 | 31 000 | 20 000 | 20 000 | 12 000 | 12 000 | 6000 | 6000 | 3000 | 3000 |
| | 1500 | 40 000 | 40 000 | 40 000 | 40 000 | 40 000 | 40 000 | 24 000 | 24 000 | 13 000 | 13 000 | 7000 | 7000 |
| | 1000 | 40 000 | 40 000 | 40 000 | 40 000 | 40 000 | 40 000 | 33 000 | 33 000 | 18 000 | 18 000 | 9000 | 9000 |
| | 750 | 40 000 | 40 000 | 40 000 | 40 000 | 40 000 | 40 000 | 33 000 | 33 000 | 18 000 | 18 000 | 9000 | 9000 |
| 160 | 3000 | 40 000 | 40 000 | 40 000 | 36 000 | 40 000 | 19 000 | 26 000 | 9000 | 14 000 | 5000 | 8000 | 2000 |
| | 1500 | 40 000 | 40 000 | 40 000 | 40 000 | 40 000 | 40 000 | 40 000 | 38 000 | 40 000 | 20 000 | 37000 | 10 000 |
| | 1000 | 40 000 | 40 000 | 40 000 | 40 000 | 40 000 | 40 000 | 40 000 | 40 000 | 40 000 | 24 000 | 40 000 | 12 000 |
| | 750 | 40 000 | 40 000 | 40 000 | 40 000 | 40 000 | | 40 000 | | 40 000 | | 40 000 | |
| 180 | 3000 | 38 000 | 38 000 | 38 000 | 38 000 | 38 000 | 38 000 | 38 000 | 23 000 | 23 000 | 12 000 | 13 000 | 7000 |
| | 1500 | 40 000 | 40 000 | 40 000 | 40 000 | 40 000 | 24 000 | 40 000 | 12 000 | 26 000 | 6000 | 13 000 | 3000 |
| | 1000 | 40 000 | 40 000 | 40 000 | 40 000 | 40 000 | 40 000 | 40 000 | 40 000 | 40 000 | 24 000 | 29 000 | 12 000 |
| | 750 | 40 000 | | 40 000 | | 40 000 | | 40 000 | | 37000 | | 21 000 | |
| 200 | 3000 | 27 000 | 27 000 | 27 000 | 27 000 | 27 000 | 18 000 | 24 000 | 10 000 | 14 000 | 5000 | 8000 | 3000 |
| | 1500 | 40 000 | 40 000 | 40 000 | 40 000 | 40 000 | 40 000 | 40 000 | 32000 | 40 000 | 18 000 | 30 000 | 10 000 |
| | 1000 | 40 000 | 40 000 | 40 000 | 40 000 | 40 000 | 40 000 | 40 000 | 40 000 | 40 000 | 30 000 | 38 000 | 17 000 |
| | 750 | 40 000 | | 40 000 | | 40 000 | | 40 000 | | 40 000 | | 40 000 | |
| 225 | 3000 | 23 000 | 23 000 | 23 000 | 18 000 | 23 000 | 10 000 | 20 000 | 6000 | 12 000 | 3000 | 7000 | 1000 |
| | 1500 | 40 000 | 40 000 | 40 000 | 40 000 | 40 000 | 23 000 | 40 000 | 12 000 | 40 000 | 6000 | 25 000 | 3000 |
| | 1000 | 40 000 | 40 000 | 40 000 | 40 000 | 40 000 | 40 000 | 40 000 | 40 000 | 40 000 | 40 000 | 40 000 | 27 000 |
| | 750 | 40 000 | | 40 000 | | 40 000 | | 40 000 | | 40 000 | | 40 000 | |
| 250 | 3000 | 16 000 | 16 000 | 16 000 | 13 000 | 16 000 | 7000 | 12 000 | 4000 | 7000 | 2000 | 4000 | 1000 |
| | 1500 | 40 000 | 40 000 | 40 000 | 39 000 | 40 000 | 21 000 | 40 000 | 11 000 | 33 000 | 6000 | 19 000 | 3000 |
| | 1000 | 40 000 | 40 000 | 40 000 | 40 000 | 40 000 | 40 000 | 40 000 | 40 000 | 40 000 | 25 000 | 36 000 | 13 000 |
| | 750 | 40 000 | | 40 000 | | 40 000 | | 40 000 | | 40 000 | | 40 000 | |

¹⁾all types except ²⁾112 J-gen

³⁾all types except ⁴⁾SM_

Grease lifetime L₁₀ in deep groove ball bearings of type 2Z in horizontally mounted motors in continuous running duty.

Radial forces

Permissible loading on shaft

The tables give the permissible radial force in Newtons, assuming zero axial force, ambient temperature of 25°C.

Permissible loads of simultaneous radial and axial forces will be supplied on request.

The bearing life, L_{10} , is calculated according to SKF's theory on bearing life L_{10aah} , which also takes the purity of the grease into consideration. An adequate lubrication is a necessary prerequisite for the table at right.

If the radial force is applied between points X_0 and X_{max} , the permissible force F_R can be calculated from the following formula:

$$F_R = F_{X0} - \frac{X}{E} (F_{X0} - F_{Xmax})$$

Where:

E: length of the shaft extension in the standard version

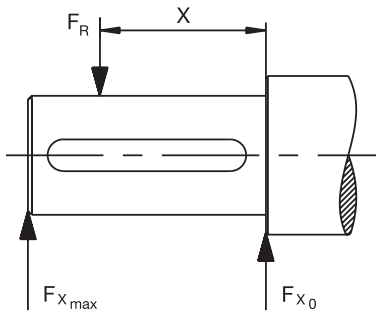

Permissible radial forces

Motor sizes 63 to 132

| Motor size | Poles | Length of shaft extension E (mm) | Ball bearings Basic design with deep groove ball bearings | | | |
|-------------------|-------|-------------------------------------|--------------------------------------------------------------|----------------|--------------|----------------|
| | | | 25000 hours | | 40000 hours | |
| | | | F_{x0} (N) | F_{xmax} (N) | F_{x0} (N) | F_{xmax} (N) |
| 63 | 2-8 | 23 | 490 | 400 | 490 | 400 |
| 71 | 2-8 | 30 | 680 | 570 | 680 | 570 |
| 80 | 2 | 40 | 630 | 750 | 930 | 750 |
| 80 | 4-8 | 40 | 930 | 750 | 930 | 750 |
| 90 | 2-8 | 50 | 1010 | 810 | 1010 | 810 |
| 100 | 2-8 | 60 | 2280 | 1800 | 2280 | 1800 |
| 112 | 2-8 | 60 | 2280 | 1800 | 2280 | 1800 |
| 112 ¹⁾ | 2-6 | 60 | 1770 | 1430 | 1560 | 1260 |
| 132 ²⁾ | 2-8 | 80 | 2120 | 1610 | 2120 | 1610 |
| 132 ³⁾ | 2-8 | 80 | 2600 | 2100 | 2600 | 2100 |

¹⁾ 112 J-gen

²⁾ 62-series bearings

³⁾ 63-series bearings

Motor sizes 160 to 280

| Motor size | Poles | Length of shaft extension E (mm) | Ball bearings Basic design with deep groove ball bearings | | | | Roller bearings Alternative design with roller bearings | | | |
|------------|-------|-------------------------------------|--------------------------------------------------------------|--------------------|--------------------|--------------------|------------------------------------------------------------|----------------|--------------|----------------|
| | | | 20 000 hrs | | 40 000 hrs | | 20 000 hrs | | 40 000 hrs | |
| | | | F_{x0} (N) | F_{xmax} (N) | F_{x0} (N) | F_{xmax} (N) | F_{x0} (N) | F_{xmax} (N) | F_{x0} (N) | F_{xmax} (N) |
| 160 | 2 | 110 | 4760 | 3860 | 4100 | 3320 | 6580 | 4300 | 5620 | 4300 |
| | 4 | 110 | 5180 | 4200 | 4380 | 3545 | 7340 | 4300 | 6180 | 4300 |
| | 6 | 110 | 5160 | 4180 | 4360 | 3540 | 7780 | 4300 | 6500 | 4300 |
| | 8 | 110 | 6280 | 4300 | 5320 | 4300 | 8860 | 4300 | 7440 | 4300 |
| 180 | 2 | 110 | 6060 | 4960 | 5280 ¹⁾ | 4305 ¹⁾ | 7600 | 5500 | 6560 | 5500 |
| | 4 | 110 | 4800 | 3940 | 4020 | 3300 | 7280 | 5500 | 6140 | 5500 |
| | 6 | 110 | 6280 | 5140 | 5280 | 4380 | 8680 | 5500 | 7280 | 5500 |
| | 8 | 110 | 6960 | 5500 | 5880 | 4800 | 9440 | 5500 | 7920 | 5500 |
| 200 | 2 | 110 | 7800 | 6500 | 6760 ²⁾ | 5640 ²⁾ | 10 360 | 8640 | 8880 | 7400 |
| | 4 | 110 | 8400 | 7020 | 7180 | 5980 | 11 560 | 9550 | 9800 | 8180 |
| | 6 | 110 | 8960 | 7480 | 7600 | 6340 | 12 480 | 9550 | 10 520 | 8780 |
| | 8 | 110 | 10480 | 8740 | 8940 | 7400 | 14 100 | 9550 | 11 920 | 9550 |
| 225 | 2 | 110 | 8520 | 7180 | 7360 ³⁾ | 6200 ³⁾ | 12 320 | 10 380 | 10 560 | 8900 |
| | 4 | 140 | 8380 | 6780 | 7200 | 5820 | 13 380 | 10 250 | 11 320 | 9160 |
| | 6 | 140 | 10 960 | 8860 | 9360 | 7560 | 15 860 | 10 250 | 13 420 | 10 250 |
| | 8 | 140 | 12 100 | 9780 | 10 340 | 8360 | 17 220 | 10 250 | 14 580 | 10 250 |
| 250 | 2 | 140 | 10 480 ⁴⁾ | 8500 ⁴⁾ | 9080 ⁴⁾ | 7360 ⁴⁾ | 16 220 | 10 900 | 13 960 | 10 900 |
| | 4 | 140 | 10 840 | 8780 | 9380 | 7600 | 18 020 | 13 800 | 15 320 | 13 800 |
| | 6 | 140 | 12 600 | 10 220 | 10 700 | 8680 | 20 240 | 13 800 | 17 140 | 13 800 |
| | 8 | 140 | 14 660 | 11 880 | 12 540 | 10 160 | 22 680 | 13 800 | 19 220 | 13 800 |
| 280 | 2 | 140 | 6780 | 5500 | 5680 | 4600 | 16 280 | 13 200 | 14 000 | 11 360 |
| | 4 | 140 | 8060 | 6540 | 6640 | 5380 | 19 480 | 15 780 | 16 540 | 13 400 |
| | 6 | 140 | 8980 | 7280 | 7360 | 5960 | 21 920 | 17 760 | 18 580 | 15 060 |
| | 8 | 140 | 9180 | 7460 | 7460 | 6060 | 22 240 | 18 020 | 18 860 | 15 300 |

¹⁾ The maximum lifetime of the grease is 38000 h

²⁾ The maximum lifetime of the grease is 27000 h

³⁾ The maximum lifetime of the grease is 23000 h

⁴⁾ The maximum lifetime of the grease is 16000 h

Axial forces

The following tables present permissible axial forces on the shaft in Newtons, assuming zero radial force, a 25 °C ambient temperature, and normal conditions. The values are given for a calculated bearing life of 20,000 and 40,000 hours per motor size.

At 60 Hz, the values must be reduced by 10 percent, and for two-speed motors, the higher speed determines permissible axial force. Permissible loads of simultaneous radial and axial forces can be supplied on request.

For axial force F_{AD} , it is assumed that the D-bearing is locked with a locking ring.

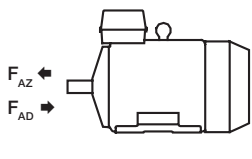

Mounting arrangement IM B3

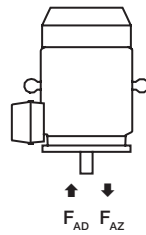

Mounting arrangement IM V1

Permissible axial forces, motor sizes 63 - 280

| Motor size | Poles | Mounting arrangement IM B3, deep groove ball bearings | | | | Mounting arrangement IM V1, deep groove ball bearings | | | |
|------------|-------|-------------------------------------------------------|--------------|--------------|--------------|-------------------------------------------------------|--------------|--------------|--------------|
| | | 20 000 hours | | 40 000 hours | | 20 000 hours | | 40 000 hours | |
| | | F_{AD} (N) | F_{AZ} (N) | F_{AD} (N) | F_{AZ} (N) | F_{AD} (N) | F_{AZ} (N) | F_{AD} (N) | F_{AZ} (N) |
| 63 | 2 | 480 | 125 | 420 | 105 | 495 | 115 | 440 | 95 |
| | 4 | 565 | 165 | 470 | 115 | 585 | 155 | 490 | 105 |
| | 6 | 580 | 190 | 490 | 145 | 600 | 180 | 550 | 115 |
| | 8 | 590 | 195 | 590 | 205 | | | | |
| 71 | 2 | 625 | 325 | 515 | 215 | 640 | 315 | 530 | 200 |
| | 4 | 780 | 480 | 630 | 330 | 800 | 470 | 650 | 320 |
| | 6 | 890 | 590 | 710 | 410 | 925 | 570 | 745 | 390 |
| | 8 | 985 | 685 | 780 | 480 | 1020 | 665 | 815 | 455 |
| 80 | 2 | 810 | 470 | 650 | 315 | 845 | 450 | 690 | 290 |
| | 4 | 1015 | 675 | 810 | 470 | 1075 | 640 | 865 | 430 |
| | 6 | 1170 | 830 | 925 | 595 | 1225 | 795 | 980 | 550 |
| | 8 | 1300 | 960 | 1015 | 675 | 1350 | 925 | 1070 | 645 |
| 90 | 2 | 885 | 485 | 720 | 320 | 945 | 450 | 775 | 280 |
| | 4 | 1170 | 650 | 945 | 425 | 1245 | 600 | 1020 | 375 |
| | 6 | 1270 | 870 | 1005 | 605 | 1360 | 815 | 1095 | 550 |
| | 8 | 1410 | 1010 | 1110 | 710 | 1485 | 960 | 1185 | 660 |
| 100 | 2 | 1620 | 1120 | 1280 | 780 | 1710 | 1060 | 1370 | 715 |
| | 4 | 2065 | 1565 | 1615 | 1115 | 2180 | 1485 | 1735 | 1035 |
| | 6 | 2390 | 1890 | 1860 | 1360 | 2510 | 1815 | 1980 | 1285 |
| | 8 | 2660 | 2160 | 2065 | 1565 | 2780 | 2080 | 2185 | 1485 |
| 112 M, MB | 2 | 1615 | 1115 | 1275 | 775 | 1725 | 1040 | 1385 | 700 |
| | 4 | 2060 | 1560 | 1610 | 1110 | 2210 | 1460 | 1110 | 1010 |
| | 6 | 2385 | 1885 | 1860 | 1360 | 2540 | 1785 | 2010 | 1260 |
| | 8 | 2655 | 2155 | 2060 | 1560 | 2790 | 2055 | 2195 | 1475 |
| 112 J-gen | 2 | 1500 | 1000 | 1160 | 660 | 1610 | 1010 | 1260 | 675 |
| | 4 | 1600 | 1100 | 2160 | 760 | 2100 | 1430 | 985 | 885 |
| | 6 | 1720 | 1220 | 1380 | 880 | 2430 | 1760 | 1885 | 1135 |
| | 8 | 1760 | 1260 | 1420 | 920 | 2880 | 1740 | 2075 | 1325 |

Permissible axial forces, motor sizes 63 - 280

| Motor size | Poles | Mounting arrangement IM B3, deep groove ball bearings | | | | Mounting arrangement IM V1, deep groove ball bearings | | | |
|-------------|-------|-------------------------------------------------------|--------------------|--------------------|--------------------|-------------------------------------------------------|--------------------|--------------------|--------------------|
| | | 20 000 hours | | 40 000 hours | | 20 000 hours | | 40 000 hours | |
| | | F_{AD} (N) | F_{AZ} (N) | F_{AD} (N) | F_{AZ} (N) | F_{AD} (N) | F_{AZ} (N) | F_{AD} (N) | F_{AZ} (N) |
| 132 M, MA | 4 | 2245 | 1645 | 1760 | 1160 | 2460 | 1505 | 1970 | 1015 |
| | 6 | 2595 | 1980 | 2025 | 1425 | 2815 | 1850 | 2245 | 1280 |
| | 8 | 2875 | 2270 | 2240 | 1640 | 3130 | 2115 | 2490 | 1470 |
| 132 MC | 6 | 2580 | 1980 | 2010 | 1410 | 2885 | 1780 | 2315 | 1210 |
| 132 MBA | 4 | 2235 | 1635 | 1750 | 1150 | 2495 | 1465 | 2010 | 980 |
| 132 S | 6 | 2600 | 2000 | 2030 | 1435 | 2780 | 1885 | 2210 | 1315 |
| | 8 | 2885 | 2285 | 2245 | 1645 | 3100 | 2145 | 2460 | 1505 |
| 132 SB | 2 | 1760 | 1160 | 1400 | 800 | 1910 | 1075 | 1540 | 705 |
| 132 SBB, SC | 2 | 1760 | 1160 | 1395 | 795 | 1945 | 1045 | 1575 | 670 |
| 132 SMB, | 2 | 2210 | 1610 | 1740 | 1140 | 2435 | 1470 | 1950 | 985 |
| SMC | 4 | 2840 | 2240 | 2205 | 1605 | 3150 | 2035 | 2515 | 1400 |
| 132 SMD | 4 | 2830 | 2200 | 2230 | 1595 | 3195 | 1995 | 2560 | 1355 |
| 132 SME | 2 | 2210 | 1610 | 1730 | 1130 | 2490 | 1425 | 2005 | 940 |
| 160 | 2 | 4160 | 4160 | 3425 | 3425 | 4560 | 3810 | 3860 | 3110 |
| | 4 | 4740 | 4740 | 3920 | 3920 | 5260 | 4310 | 4440 | 3490 |
| | 6 | 4840 | 4840 | 4000 | 4000 | 5400 | 4420 | 4540 | 3560 |
| 180 | 2 | 5980 | 5980 | 4920 | 4920 | 6560 | 5580 | 5460 | 4480 |
| | 4 | 5480 | 5480 | 4600 ¹⁾ | 4600 ¹⁾ | 5920 | 5115 | 5060 ¹⁾ | 4255 ¹⁾ |
| | 6 | 4360 | 4360 | 3540 | 3540 | 5080 | 3860 | 4240 | 3020 |
| 200 | 2 | 6000 | 6620 | 5460 | 5460 | 6000 | 6120 | 6000 | 4900 |
| | 4 | 5000 | 6880 | 5000 ²⁾ | 5700 ²⁾ | 5000 | 6350 | 5000 ²⁾ | 5230 ²⁾ |
| | 6 | 5000 | 7660 | 5000 | 6340 | 5000 | 6950 | 5000 | 5650 |
| 225 | 2 | 5000 | 8300 | 5000 | 6880 | 5000 | 7505 | 5000 | 6025 |
| | 4 | 5000 | 9880 | 5000 | 8160 | 5000 | 9215 | 5000 | 7435 |
| | 6 | 5000 | 7380 | 5000 ³⁾ | 6120 ³⁾ | 5000 | 6770 | 5000 ³⁾ | 5490 ³⁾ |
| 250 | 2 | 5000 | 7600 | 5000 | 6220 | 5000 | 6795 | 5000 | 5475 |
| | 4 | 5000 | 10140 | 5000 | 8420 | 5000 | 9270 | 5000 | 7490 |
| | 6 | 5000 | 11 420 | 5000 | 9460 | 5000 | 10 595 | 5000 | 8535 |
| 280 | 2 | 6000 ⁴⁾ | 9020 ⁴⁾ | 6000 ⁴⁾ | 7500 ⁴⁾ | 6000 ⁴⁾ | 8335 ⁴⁾ | 6000 ⁴⁾ | 6755 ⁴⁾ |
| | 4 | 6000 | 9800 | 6000 | 8040 | 6000 | 8820 | 6000 | 7120 |
| | 6 | 6000 | 11520 | 6000 | 9520 | 6000 | 10 275 | 6000 | 8235 |
| 280 | 2 | 6000 | 13 700 | 6000 | 11 380 | 6000 | 12 645 | 6000 | 10 205 |
| | 4 | 5260 | 5260 | 4220 | 4220 | 6400 | 4400 | 5420 | 3420 |
| | 6 | 6500 | 6500 | 5160 | 5160 | 7920 | 5400 | 6640 | 4120 |
| 280 | 2 | 7500 | 7500 | 6040 | 6040 | 8500 | 6180 | 7840 | 4640 |
| | 4 | 7740 | 7740 | 6180 | 6180 | 8500 | 6435 | 7980 | 4775 |

¹⁾ The maximum lifetime of the grease is 38 000 h

²⁾ The maximum lifetime of the grease is 27 000 h

³⁾ The maximum lifetime of the grease is 23 000 h

⁴⁾ The maximum lifetime of the grease is 16 000 h

Terminal box

Sizes 63 to 180

The terminal box is made of aluminum alloy and is located on top of the stator. The lower part of the box is integrated with the stator. It is provided with two knockout openings on each side. Sizes 132 SM_ and 160 - 180 also have a third smaller opening. Cable glands are not included.

Sizes 200 to 280

The terminal box and cover are made of deep drawn steel and mounted on top of the stator. The box is bolted to the stator and is not rotatable. The size of the box is the same for all frame sizes.

The motors can also be provided with an extra large terminal box, standard for voltage code S and frame size 280. See variant code 019 under the heading "Terminal box". This will increase the dimension HD by 32 mm. The box is supplied with two FL 21 openings. The right opening is provided with a flange with two holes for M63 cable glands. The holes are sealed by means of plastic plugs. Cable glands are not supplied. The opening on the other side is provided with a cover flange. The box can also be provided with an FL 13 opening towards the N-end.

When new motors are manufactured the terminal box can be mounted on the left or the right side. See variant codes 021 and 180 under the heading "Terminal box".

In the basic design the terminal box is provided with two FL 13 flange openings, one on each side. The opening on the right side, seen from the D-end, is supplied with a flange with two holes for M40 cable glands. On delivery the holes are sealed by means of plastic plugs. Cable glands are not supplied. The opening on the other side is provided with a cover flange.

Dimensions for terminal box

| Motor size | Dimensions | | |
|--------------------------------------------------------------------------------------------------------------|------------|-------|-------|
| | HB | HD | HE |
| Code 019: Larger than standard terminal box | | | |
| 200 ML | 332.5 | 603 | 240 |
| 225 SM | 353 | 578 | 260.5 |
| 250 SM | 376 | 626 | 283.5 |
| Code 021: Terminal box on left-hand side seen from D end | | | |
| Code 180: Terminal box on right-hand side seen from D end | | | |
| 200 ML | 332 | 532 | 239 |
| 225 SM | 354 | 579 | 260.5 |
| 250 SM | 377 | 627 | 284 |
| Code 467: Lower than standard terminal box without screw terminals and extended rubber connection cable 2 m. | | | |
| 160 | 211.5 | 371.5 | |
| 180 | 226.5 | 406.5 | |
| 200 ML | 248 | 448 | |
| 225 SM | 269 | 494 | |
| 250 SM | 292 | 542 | |
| 280 | 292 | 572 | |

Refer to the Dimension drawings section for dimensions HB, HD and HE.

Connections

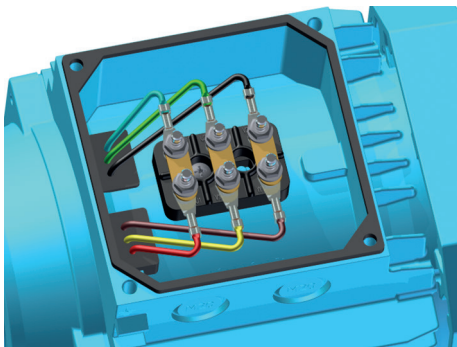

Terminal board for motor sizes 63 to 80

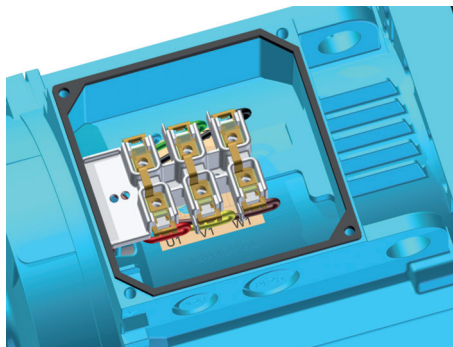

Terminal board for motor sizes 90 to 112

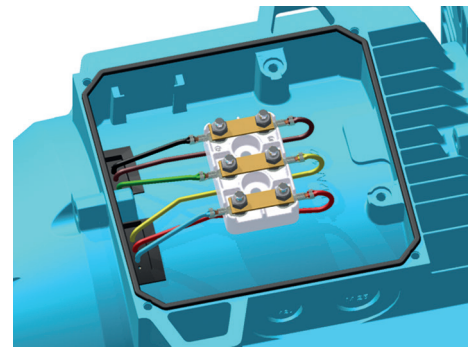

Terminal board for motor size 132

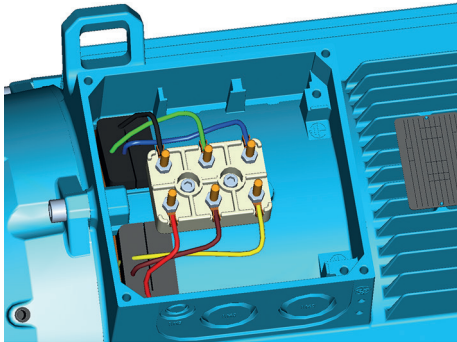

Terminal board for motor sizes 160 to 180 in G-generation

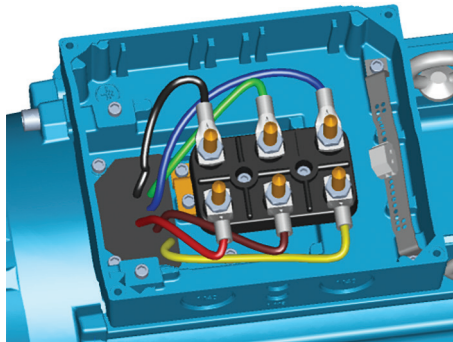

Terminal board for motor sizes 160 to 200 in L-generation

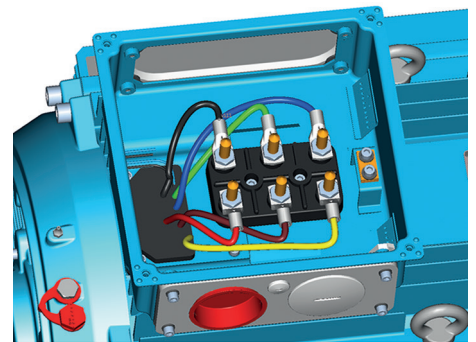

Terminal board for motor sizes 200 to 280 in G-generation

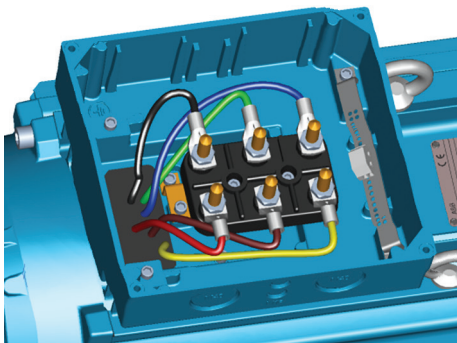

Terminal board for motor sizes 225 to 280 in L-generation

The terminal block is provided with six terminals for connecting Cu-cable.
The terminals are marked in accordance with IEC 60034-8.

Connection openings

| Motor size | Opening | Metric cable entry | Method of connection | Terminal bolt size | Maximum connectable Cu-cable area, mm ² |
|-------------------|-------------------|----------------------------|----------------------|--------------------|----------------------------------------------------|
| 63 | Knock-out opening | 1 x M16 x 1.5 1 x Pg 11 | Cable lug | M4 | 2.5 |
| 71-80 | Knock-out opening | 2 x (2 x M20) | Cable lug | M4 | 4 |
| 90-112 | Knock-out opening | 2 x (M25 + M20) | Screw terminal | M4 | 6 |
| 132 ¹⁾ | Knock-out opening | 2 x (M25 + M20) | Cable lug | M5 | 10 |
| 132 ²⁾ | Knock-out opening | 2 x (M40 x M32 + M12) | Cable lug | M6 | 35 |
| 160-180 | Knock-out opening | 2 x (2 x M40) + M16 | Cable lug | M6 | 35 |
| 200-250 | 2 x FL 13 | 1 x (2 x M40 + M16) | Cable lug | M10 | 70 |
| 280 | 2 x FL 21 | 1 x (2 x M63 + M16) | Cable lug | M10 | 70 |

¹⁾all types except ²⁾

²⁾SM_

Dimension drawings

Foot-mounted aluminum motors, 63 - 112

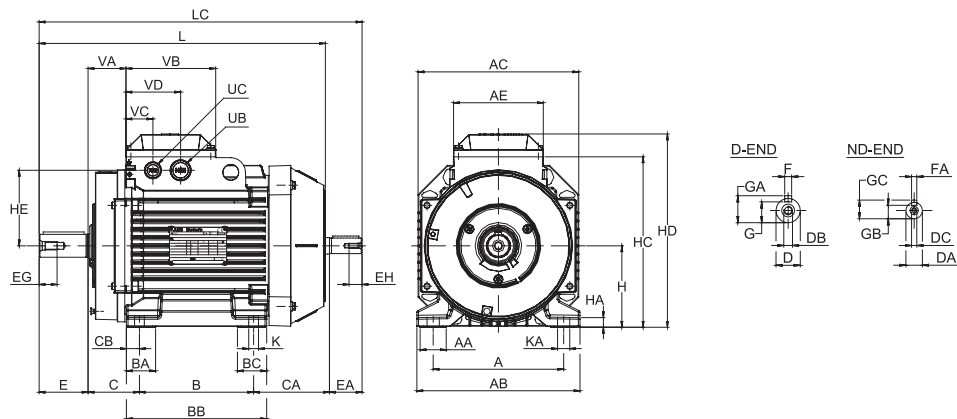

Foot-mounted motor; IM B3 (IM 1001), IM 1002

IM B3 (IM 1001), IM 1002

| Motor size | A | AA | AB | AC | AE | B | BA | BB | BC | C | CA | CB | D | DA | DB | DC | E | EA | EG | EH | F |
|--------------------|-----|----|-----|-----|-----|-----|------|-----|------|----|-------|------|----|----|-----|----|----|----|------|------|---|
| 63 | 100 | 25 | 120 | 120 | 85 | 80 | 32 | 98 | 32 | 40 | 74 | 10 | 11 | 11 | M4 | M4 | 23 | 23 | 10 | 10 | 4 |
| 71 | 112 | 23 | 136 | 130 | 97 | 90 | 24.5 | 110 | 24.5 | 45 | 79.5 | 10 | 14 | 11 | M5 | M4 | 30 | 23 | 12.5 | 10 | 5 |
| 80 ¹⁾ | 125 | 27 | 154 | 150 | 97 | 100 | 32 | 125 | 32 | 50 | 80.5 | 12.5 | 19 | 14 | M6 | M5 | 40 | 30 | 16 | 12.5 | 6 |
| 80 ²⁾ | 125 | 27 | 154 | 150 | 97 | 100 | 32 | 125 | 32 | 50 | 108 | 12.5 | 19 | 14 | M6 | M5 | 40 | 30 | 16 | 12.5 | 6 |
| 90 ³⁾ | 140 | 27 | 170 | 177 | 110 | 100 | 32 | 125 | 32 | 56 | 83.5 | 12.5 | 24 | 14 | M8 | M5 | 50 | 30 | 19 | 12.5 | 8 |
| 90 ⁴⁾ | 140 | 27 | 170 | 177 | 110 | 125 | 32 | 150 | 32 | 56 | 83.5 | 12.5 | 24 | 14 | M8 | M5 | 50 | 30 | 19 | 12.5 | 8 |
| 90 ⁵⁾ | 140 | 27 | 170 | 177 | 110 | 125 | 32 | 150 | 32 | 56 | 105.5 | 12.5 | 24 | 14 | M8 | M5 | 50 | 30 | 19 | 12.5 | 8 |
| 100 ⁶⁾ | 160 | 32 | 200 | 197 | 110 | 140 | 36 | 172 | 36 | 63 | 93 | 16 | 28 | 19 | M10 | M6 | 60 | 40 | 22 | 16 | 8 |
| 100 ⁷⁾ | 160 | 32 | 200 | 197 | 110 | 140 | 36 | 172 | 36 | 63 | 115 | 16 | 28 | 19 | M10 | M6 | 60 | 40 | 22 | 16 | 8 |
| 100 ⁸⁾ | 160 | 32 | 200 | 197 | 110 | 140 | 36 | 172 | 36 | 63 | 136 | 16 | 28 | 19 | M10 | M6 | 60 | 40 | 22 | 16 | 8 |
| 112 ⁹⁾ | 190 | 32 | 230 | 197 | 110 | 140 | 36 | 172 | 36 | 70 | 136 | 16 | 28 | 19 | M10 | M6 | 60 | 40 | 22 | 16 | 8 |
| 112 ¹⁰⁾ | 190 | 41 | 222 | 221 | 160 | 140 | 31 | 168 | 31 | 70 | 123 | 14 | 28 | 19 | M10 | M8 | 60 | 40 | 22 | 19 | 8 |
| 112 ¹¹⁾ | 190 | 41 | 222 | 221 | 160 | 140 | 31 | 168 | 31 | 70 | 143 | 14 | 28 | 19 | M10 | M8 | 60 | 40 | 22 | 19 | 8 |

| Motor size | FA | G | GA | GB | GC | H | HA | HC | HD | HE | K | KA | L | LC | UB | UC | VA | VB | VC | VD |
|--------------------|----|------|------|------|------|-----|----|-------|-------|------|----|----|-------|-------|------|---------|------|-----|------|------|
| 63 | 4 | 8.5 | 12.5 | 8.5 | 12.5 | 63 | 7 | 120 | 151 | 50 | 7 | 11 | 214 | 237 | pg11 | M16x1.5 | 31 | 92 | 30.5 | 61.5 |
| 71 | 4 | 11 | 16 | 8.5 | 12.5 | 71 | 9 | 151 | 180 | 63.5 | 7 | 11 | 240 | 267 | M20 | M20 | 35 | | | |
| 80 ¹⁾ | 5 | 15.5 | 21.5 | 11 | 16 | 80 | 10 | 164.5 | 193.5 | 68 | 10 | 14 | 265.5 | 300.5 | M20 | M20 | 37.5 | 97 | 30.5 | 66.5 |
| 80 ²⁾ | 5 | 15.5 | 21.5 | 11 | 16 | 80 | 10 | 164.5 | 193.5 | 68 | 10 | 14 | 293 | 328 | M20 | M20 | 37.5 | 97 | 30.5 | 66.5 |
| 90 ³⁾ | 5 | 20 | 27 | 11 | 16 | 90 | 10 | 189 | 217 | 82.5 | 10 | 14 | 284.5 | 319.5 | M25 | M20 | 43.5 | 110 | 33 | 67 |
| 90 ⁴⁾ | 5 | 20 | 27 | 11 | 16 | 90 | 10 | 189 | 217 | 82.5 | 10 | 14 | 309.5 | 344.5 | M25 | M20 | 43.5 | 110 | 33 | 67 |
| 90 ⁵⁾ | 5 | 20 | 27 | 11 | 16 | 90 | 10 | 189 | 217 | 82.5 | 10 | 14 | 331.5 | 366.5 | M25 | M20 | 43.5 | 110 | 33 | 67 |
| 100 ⁶⁾ | 6 | 24 | 31 | 15.5 | 21.5 | 100 | 12 | 209 | 237 | 92.5 | 12 | 15 | 351 | 396 | M25 | M20 | 46.5 | 110 | 33 | 67 |
| 100 ⁷⁾ | 6 | 24 | 31 | 15.5 | 21.5 | 100 | 12 | 209 | 237 | 92.5 | 12 | 15 | 373 | 418 | M25 | M20 | 46.5 | 110 | 33 | 67 |
| 100 ⁸⁾ | 6 | 24 | 31 | 15.5 | 21.5 | 100 | 12 | 209 | 237 | 92.5 | 12 | 15 | 393 | 436 | M25 | M20 | 46.5 | 110 | 33 | 67 |
| 112 ⁹⁾ | 6 | 24 | 31 | 15.5 | 21.5 | 112 | 12 | 221 | 249 | 92.5 | 12 | 15 | 393 | 436 | M25 | M20 | 46.5 | 110 | 33 | 67 |
| 112 ¹⁰⁾ | 6 | 24 | 31 | 15.5 | 21.5 | 112 | 12 | 226 | 258 | 92 | 12 | 15 | 390 | 433 | M25 | M20 | 60 | 160 | 80 | 120 |
| 112 ¹¹⁾ | 6 | 24 | 31 | 15.5 | 21.5 | 112 | 12 | 226 | 258 | 92 | 12 | 15 | 410 | 453 | M25 | M20 | 60 | 160 | 80 | 120 |

Tolerances

Footnotes

| | | | |
|-------|---------|----------------------------------------------------------------|-------------------------------------------------------|
| A, B | ±0.8 | ¹⁾ IE2: B-2, C-2, A-4, D-4, A-6, B-6, A-8, B-8, C-8 | ⁶⁾ IE2: LB-2, LC-4, LC-6, LA-8, LB-8, LC-8 |
| D, DA | ISO j6 | IE3: B-2, C-2 | IE3: LC-4 |
| F, FA | ISO h9 | ²⁾ IE3: E-4 | ⁷⁾ IE2: LD-4 |
| H | +0 -0.5 | ³⁾ IE2: S-8 | ⁸⁾ IE3: LB-2, LC-6, LD-4 |
| N | ISO j6 | ⁴⁾ IE2: L-2, L-8, LB-2, LB-4, LB-6, LB-8 | ⁹⁾ IE2: MB-2, MB-4, MB-6, MB-8, M-8 |
| C, CA | ±0.8 | IE3: L-2, LB-2, LB-4, LB-6 | ¹⁰⁾ IE3: MB-2 |
| | | ⁵⁾ IE2: LD-4, LD-6 | ¹¹⁾ IE3: MB-4 |
| | | IE3: LD-4, LD-6 | |

Dimension drawings

Flange-mounted aluminum motors, 63 - 112

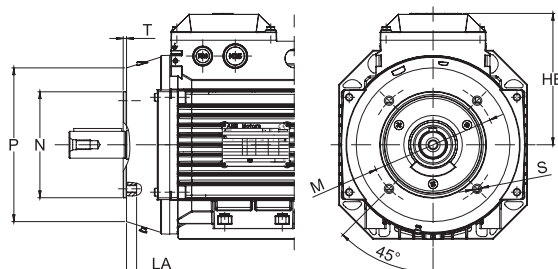
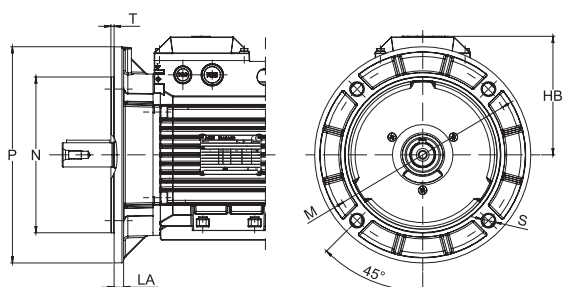

Flange-mounted motor, large flange; IM B5 (IM 3001), IM 3002

Flange-mounted motor, small flange; IM B14 (IM 3601)

IM B5 (IM3001), IM 3002

| Motor size | HB | LA | M | N | P | S | T |
|--------------------|-------|-----|-----|-----|-----|----|-----|
| 63 | 103 | 10 | 100 | 80 | 120 | 7 | 3 |
| 71 | 109 | 9.5 | 130 | 110 | 160 | 10 | 3.5 |
| 80 ¹⁾ | 113.5 | 10 | 165 | 130 | 200 | 12 | 3.5 |
| 80 ²⁾ | 113.5 | 10 | 165 | 130 | 200 | 12 | 3.5 |
| 90 ³⁾ | 127 | 10 | 165 | 130 | 200 | 12 | 3.5 |
| 90 ⁴⁾ | 127 | 10 | 165 | 130 | 200 | 12 | 3.5 |
| 90 ⁵⁾ | 127 | 10 | 165 | 130 | 200 | 12 | 3.5 |
| 100 ⁶⁾ | 137 | 11 | 215 | 180 | 250 | 15 | 4 |
| 100 ⁷⁾ | 137 | 11 | 215 | 180 | 250 | 15 | 4 |
| 100 ⁸⁾ | 137 | 11 | 215 | 180 | 250 | 15 | 4 |
| 112 ⁹⁾ | 137 | 11 | 215 | 180 | 250 | 15 | 4 |
| 112 ¹⁰⁾ | 146 | 11 | 215 | 180 | 250 | 15 | 4 |
| 112 ¹¹⁾ | 137 | 11 | 215 | 180 | 250 | 15 | 4 |

IM B14 (IM 3601), IM 3602

| Motor size | HB | LA | M | N | P | S | T |
|--------------------|-------|----|-----|-----|-----|----|-----|
| 63 | 103 | 10 | 75 | 60 | 90 | M5 | 2.5 |
| 71 | 109 | 11 | 85 | 70 | 105 | M6 | 3 |
| 80 ¹⁾ | 113.5 | 11 | 100 | 80 | 120 | M6 | 3 |
| 80 ²⁾ | 113.5 | 11 | 100 | 80 | 120 | M6 | 3 |
| 90 ³⁾ | 127 | 13 | 115 | 95 | 140 | M8 | 3 |
| 90 ⁴⁾ | 127 | 13 | 115 | 95 | 140 | M8 | 3 |
| 90 ⁵⁾ | 127 | 13 | 115 | 95 | 140 | M8 | 3 |
| 100 ⁶⁾ | 137 | 14 | 130 | 110 | 160 | M8 | 3.5 |
| 100 ⁷⁾ | 137 | 14 | 130 | 110 | 160 | M8 | 3.5 |
| 100 ⁸⁾ | 137 | 14 | 130 | 110 | 160 | M8 | 3.5 |
| 112 ⁹⁾ | 137 | 14 | 130 | 110 | 160 | M8 | 3.5 |
| 112 ¹⁰⁾ | 146 | 20 | 130 | 110 | 160 | M8 | 3.5 |
| 112 ¹¹⁾ | 137 | 14 | 130 | 110 | 160 | M8 | 3.5 |

Tolerances

| | |
|-------|---------|
| A, B | ±0.8 |
| D, DA | ISO j6 |
| F, FA | ISO h9 |
| H | +0 -0.5 |
| N | ISO j6 |
| C, CA | ±0.8 |

Footnotes

| |
|----------------------------------------------------------------|
| ¹⁾ IE2: B-2, C-2, A-4, D-4, A-6, B-6, A-8, B-8, C-8 |
| IE3: B-2, C-2 |
| ²⁾ IE3: E-4 |
| ³⁾ IE2: S-8 |
| ⁴⁾ IE2: L-2, L-8, LB-2, LB-4, LB-6, LB-8 |
| IE3: L-2, LB-2, LB-4, LB-6 |
| ⁵⁾ IE2: LD-4, LD-6 |
| IE3: LD-4, LD-6 |

| |
|-------------------------------------------------------|
| ⁶⁾ IE2: LB-2, LC-4, LC-6, LA-8, LB-8, LC-8 |
| IE3LC-4 |
| ⁷⁾ IE2: LD-4 |
| ⁸⁾ IE3: LB-2, LC-6, LD-4 |
| ⁹⁾ IE2: MB-2, MB-4, MB-6, MB-8, M-8 |
| ¹⁰⁾ IE3: MB-2 |
| ¹¹⁾ IE3: MB-4 |

Dimension drawings

Foot- and flange-mounted aluminum motors, 63 - 112

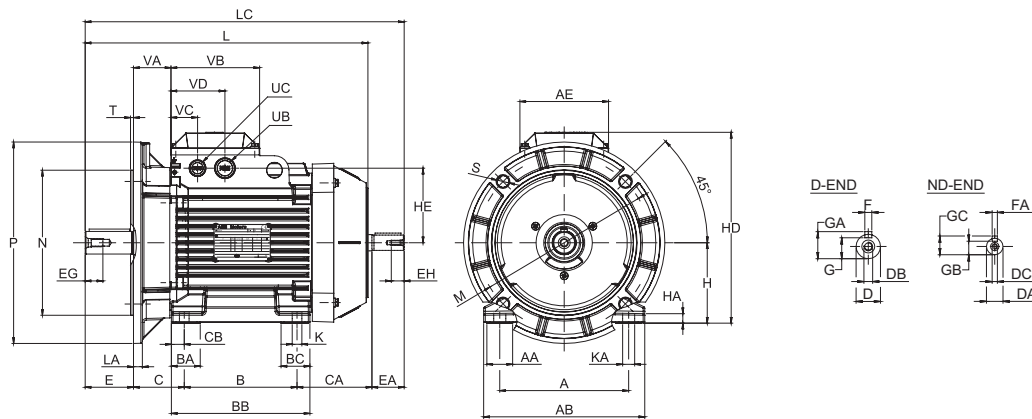

Foot- and flange-mounted motor; IM B35 (IM 2001), IM 2002, large flange

IM B35 (IM 2001), IM 2002; IM B34 (IM 2101), IM 2102

| Motor size | A | AA | AB | AC | AE | B | BA | BB | BC | C | CA | CB | D | DA | DB | DC | E | EA | EG | EH | F |
|--------------------|-----|----|-----|-----|-----|-----|------|-----|------|----|-------|------|----|----|-----|----|----|----|------|------|---|
| 63 | 100 | 25 | 120 | 120 | 85 | 80 | 32 | 98 | 32 | 40 | 74 | 10 | 11 | 11 | M4 | M4 | 23 | 23 | 10 | 10 | 4 |
| 71 | 112 | 23 | 136 | 130 | 97 | 90 | 24.5 | 110 | 24.5 | 45 | 79.5 | 10 | 14 | 11 | M5 | M4 | 30 | 23 | 12.5 | 10 | 5 |
| 80 ¹⁾ | 125 | 27 | 154 | 150 | 97 | 100 | 32 | 125 | 32 | 50 | 80.5 | 12.5 | 19 | 14 | M6 | M5 | 40 | 30 | 16 | 12.5 | 6 |
| 80 ²⁾ | 125 | 27 | 154 | 150 | 97 | 100 | 32 | 125 | 32 | 50 | 108 | 12.5 | 19 | 14 | M6 | M5 | 40 | 30 | 16 | 12.5 | 6 |
| 90 ³⁾ | 140 | 27 | 170 | 177 | 110 | 100 | 32 | 125 | 32 | 56 | 83.5 | 12.5 | 24 | 14 | M8 | M5 | 50 | 30 | 19 | 12.5 | 8 |
| 90 ⁴⁾ | 140 | 27 | 170 | 177 | 110 | 125 | 32 | 150 | 32 | 56 | 83.5 | 12.5 | 24 | 14 | M8 | M5 | 50 | 30 | 19 | 12.5 | 8 |
| 90 ⁵⁾ | 140 | 27 | 170 | 177 | 110 | 125 | 32 | 150 | 32 | 56 | 105.5 | 12.5 | 24 | 14 | M8 | M5 | 50 | 30 | 19 | 12.5 | 8 |
| 100 ⁶⁾ | 160 | 32 | 200 | 197 | 110 | 140 | 36 | 172 | 36 | 63 | 93 | 16 | 28 | 19 | M10 | M6 | 60 | 40 | 22 | 16 | 8 |
| 100 ⁷⁾ | 160 | 32 | 200 | 197 | 110 | 140 | 36 | 172 | 36 | 63 | 115 | 16 | 28 | 19 | M10 | M6 | 60 | 40 | 22 | 16 | 8 |
| 100 ⁸⁾ | 160 | 32 | 200 | 197 | 110 | 140 | 36 | 172 | 36 | 63 | 136 | 16 | 28 | 19 | M10 | M6 | 60 | 40 | 22 | 16 | 8 |
| 112 ⁹⁾ | 190 | 32 | 230 | 197 | 110 | 140 | 36 | 172 | 36 | 70 | 136 | 16 | 28 | 19 | M10 | M6 | 60 | 40 | 22 | 16 | 8 |
| 112 ¹⁰⁾ | 190 | 41 | 222 | 221 | 160 | 140 | 31 | 168 | 31 | 70 | 123 | 14 | 28 | 19 | M10 | M8 | 60 | 40 | 22 | 19 | 8 |
| 112 ¹¹⁾ | 190 | 41 | 222 | 221 | 160 | 140 | 31 | 168 | 31 | 70 | 143 | 14 | 28 | 19 | M10 | M8 | 60 | 40 | 22 | 19 | 8 |

| Motor size | FA | G | GA | GB | GC | H | HA | HC | HD | HE | K | KA | L | LC | UB | UC | VA | VB | VC | VD |
|--------------------|----|------|------|------|------|-----|----|-------|-------|------|----|----|-------|-------|------|---------|------|-----|------|------|
| 63 | 4 | 8.5 | 12.5 | 8.5 | 12.5 | 63 | 7 | 120 | 151 | 50 | 7 | 11 | 214 | 237 | pg11 | M16x1.5 | 31 | 92 | 30.5 | 61.5 |
| 71 | 4 | 11 | 16 | 8.5 | 12.5 | 71 | 9 | 151 | 180 | 63.5 | 7 | 11 | 240 | 267 | M20 | M20 | 35 | | | |
| 80 ¹⁾ | 5 | 15.5 | 21.5 | 11 | 16 | 80 | 10 | 164.5 | 193.5 | 68 | 10 | 14 | 265.5 | 300.5 | M20 | M20 | 37.5 | 97 | 30.5 | 66.5 |
| 80 ²⁾ | 5 | 15.5 | 21.5 | 11 | 16 | 80 | 10 | 164.5 | 193.5 | 68 | 10 | 14 | 293 | 328 | M20 | M20 | 37.5 | 97 | 30.5 | 66.5 |
| 90 ³⁾ | 5 | 20 | 27 | 11 | 16 | 90 | 10 | 189 | 217 | 82.5 | 10 | 14 | 284.5 | 319.5 | M25 | M20 | 43.5 | 110 | 33 | 67 |
| 90 ⁴⁾ | 5 | 20 | 27 | 11 | 16 | 90 | 10 | 189 | 217 | 82.5 | 10 | 14 | 309.5 | 344.5 | M25 | M20 | 43.5 | 110 | 33 | 67 |
| 90 ⁵⁾ | 5 | 20 | 27 | 11 | 16 | 90 | 10 | 189 | 217 | 82.5 | 10 | 14 | 331.5 | 366.5 | M25 | M20 | 43.5 | 110 | 33 | 67 |
| 100 ⁶⁾ | 6 | 24 | 31 | 15.5 | 21.5 | 100 | 12 | 209 | 237 | 92.5 | 12 | 15 | 351 | 396 | M25 | M20 | 46.5 | 110 | 33 | 67 |
| 100 ⁷⁾ | 6 | 24 | 31 | 15.5 | 21.5 | 100 | 12 | 209 | 237 | 92.5 | 12 | 15 | 373 | 418 | M25 | M20 | 46.5 | 110 | 33 | 67 |
| 100 ⁸⁾ | 6 | 24 | 31 | 15.5 | 21.5 | 100 | 12 | 209 | 237 | 92.5 | 12 | 15 | 393 | 436 | M25 | M20 | 46.5 | 110 | 33 | 67 |
| 112 ⁹⁾ | 6 | 24 | 31 | 15.5 | 21.5 | 112 | 12 | 221 | 249 | 92.5 | 12 | 15 | 393 | 436 | M25 | M20 | 46.5 | 110 | 33 | 67 |
| 112 ¹⁰⁾ | 6 | 24 | 31 | 15.5 | 21.5 | 112 | 12 | 226 | 258 | 92 | 12 | 15 | 390 | 433 | M25 | M20 | 60 | 160 | 80 | 120 |
| 112 ¹¹⁾ | 6 | 24 | 31 | 15.5 | 21.5 | 112 | 12 | 226 | 258 | 92 | 12 | 15 | 410 | 453 | M25 | M20 | 60 | 160 | 80 | 120 |

Tolerances

Footnotes

| | | |
|-------|---------|----------------------------------------------------------------|
| A, B | ± 0.8 | ¹⁾ IE2: B-2, C-2, A-4, D-4, A-6, B-6, A-8, B-8, C-8 |
| D, DA | ISO j6 | IE3: B-2, C-2 |
| F, FA | ISO h9 | ²⁾ IE3: E-4 |
| H | +0 -0.5 | ³⁾ IE2: S-8 |
| N | ISO j6 | ⁴⁾ IE2: L-2, L-8, LB-2, LB-4, LB-6, LB-8 |
| C, CA | ± 0.8 | IE3: L-2, LB-2, LB-4, LB-6 |
| | | ⁵⁾ IE2: LD-4, LD-6 |
| | | IE3: LD-4, LD-6 |

| |
|-------------------------------------------------------|
| ⁶⁾ IE2: LB-2, LC-4, LC-6, LA-8, LB-8, LC-8 |
| IE3: LC-4 |
| ⁷⁾ IE2: LD-4 |
| ⁸⁾ IE3: LB-2, LC-6, LD-4 |
| ⁹⁾ IE2: MB-2, MB-4, MB-6, MB-8, M-8 |
| ¹⁰⁾ IE3: MB-2 |
| ¹¹⁾ IE3: MB-4 |

Dimension drawings

Foot- and flange-mounted aluminum motors, 63 - 112

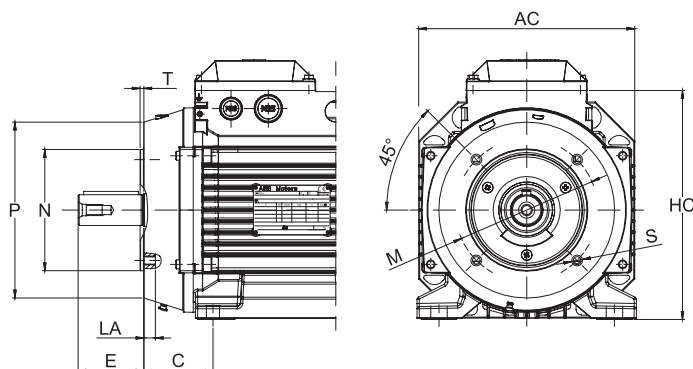

IM B35 (IM 2001), IM 2002

| Motor size | HB | LA | M | N | P | S | T |
|--------------------|-------|-----|-----|-----|-----|----|-----|
| 63 | 103 | 10 | 100 | 80 | 120 | 7 | 3 |
| 71 | 109 | 9.5 | 130 | 110 | 160 | 10 | 3.5 |
| 80 ¹⁾ | 113.5 | 10 | 165 | 130 | 200 | 12 | 3.5 |
| 80 ²⁾ | 113.5 | 10 | 165 | 130 | 200 | 12 | 3.5 |
| 90 ³⁾ | 127 | 10 | 165 | 130 | 200 | 12 | 3.5 |
| 90 ⁴⁾ | 127 | 10 | 165 | 130 | 200 | 12 | 3.5 |
| 90 ⁵⁾ | 127 | 10 | 165 | 130 | 200 | 12 | 3.5 |
| 100 ⁶⁾ | 137 | 11 | 215 | 180 | 250 | 15 | 4 |
| 100 ⁷⁾ | 137 | 11 | 215 | 180 | 250 | 15 | 4 |
| 100 ⁸⁾ | 137 | 11 | 215 | 180 | 250 | 15 | 4 |
| 112 ⁹⁾ | 137 | 11 | 215 | 180 | 250 | 15 | 4 |
| 112 ¹⁰⁾ | 146 | 11 | 215 | 180 | 250 | 15 | 4 |
| 112 ¹¹⁾ | 137 | 11 | 215 | 180 | 250 | 15 | 4 |

IM B34 (IM 2101), IM 2102

| Motor size | HB | LA | M | N | P | S | T |
|--------------------|-------|----|-----|-----|-----|----|-----|
| 63 | 103 | 10 | 65 | 50 | 80 | M5 | 2.5 |
| 71 | 109 | 11 | 85 | 70 | 105 | M6 | 3 |
| 80 ¹⁾ | 113.5 | 11 | 100 | 80 | 120 | M6 | 3 |
| 80 ²⁾ | 113.5 | 11 | 100 | 80 | 120 | M6 | 3 |
| 90 ³⁾ | 127 | 13 | 115 | 95 | 140 | M8 | 3 |
| 90 ⁴⁾ | 127 | 13 | 115 | 95 | 140 | M8 | 3 |
| 90 ⁵⁾ | 127 | 13 | 115 | 95 | 140 | M8 | 3 |
| 100 ⁶⁾ | 137 | 14 | 130 | 110 | 160 | M8 | 3.5 |
| 100 ⁷⁾ | 137 | 14 | 130 | 110 | 160 | M8 | 3.5 |
| 100 ⁸⁾ | 137 | 14 | 130 | 110 | 160 | M8 | 3.5 |
| 112 ⁹⁾ | 137 | 14 | 130 | 110 | 160 | M8 | 3.5 |
| 112 ¹⁰⁾ | 146 | 20 | 130 | 110 | 160 | M8 | 3.5 |
| 112 ¹¹⁾ | 137 | 14 | 130 | 110 | 160 | M8 | 3.5 |

Tolerances

| | |
|-------|---------|
| A, B | ± 0.8 |
| D, DA | ISO j6 |
| F, FA | ISO h9 |
| H | +0 -0.5 |
| N | ISO j6 |
| C, CA | ± 0.8 |

Footnotes

| |
|----------------------------------------------------------------|
| ¹⁾ IE2: B-2, C-2, A-4, D-4, A-6, B-6, A-8, B-8, C-8 |
| IE3: B-2, C-2 |
| ²⁾ IE3: E-4 |
| ³⁾ IE2: S-8 |
| ⁴⁾ IE2: L-2, L-8, LB-2, LB-4, LB-6, LB-8 |
| IE3: L-2, LB-2, LB-4, LB-6 |
| ⁵⁾ IE2: LD-4, LD-6 |
| IE3: LD-4, LD-6 |
| ⁶⁾ IE2: LB-2, LC-4, LC-6, LA-8, LB-8, LC-8 |
| IE3: LC-4 |
| ⁷⁾ IE2: LD-4 |
| IE3: LB-2, LC-6, LD-4 |
| ⁸⁾ IE2: MB-2, MB-4, MB-6, MB-8, M-8 |
| ¹⁰⁾ IE3: MB-2 |
| ¹¹⁾ IE3: MB-4 |

Dimension drawings

Special design aluminum motors with two-piece flanges, 71 - 132

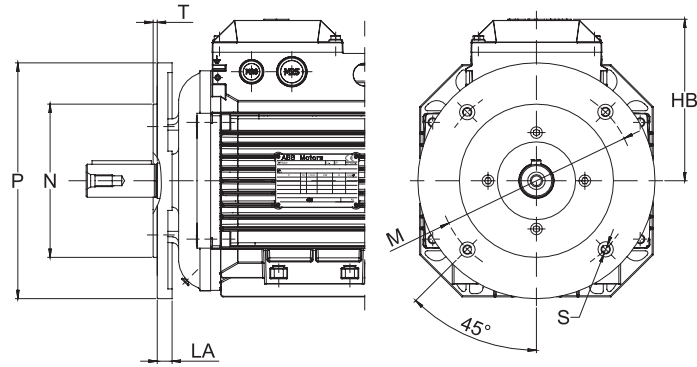

| Motor size | IEC flange | Flange dimensions | | | | | | | Variant code | |
|------------|-------------|-------------------|-----|-----|-----|------|-----|-----|--------------|-----|
| | | HB | P | M | N | LA | S | T | FF | FT |
| 71 | FT85 | 105 | 105 | 85 | 70 | 7.5 | M6 | 2.5 | - | 218 |
| | FF100/FT100 | 105 | 120 | 100 | 80 | 7.5 | M6 | 3 | 220 | 219 |
| | FF115/FT115 | 105 | 140 | 115 | 95 | 9.5 | M8 | 3 | 223 | 224 |
| | FF130/FT130 | 105 | 160 | 130 | 110 | 9.5 | M8 | 3.5 | 226 | 227 |
| | FF165/FT165 | 105 | 200 | 165 | 130 | 10.5 | M10 | 3.5 | 233 | 234 |
| 80 | FT85 | 110 | 105 | 85 | 70 | 7.5 | M6 | 2.5 | - | 218 |
| | FF100/FT100 | 110 | 120 | 100 | 80 | 7.5 | M6 | 3 | 220 | 219 |
| | FF115/FT115 | 110 | 140 | 115 | 95 | 9.5 | M8 | 3 | 223 | 224 |
| | FF130/FT130 | 110 | 160 | 130 | 110 | 9.5 | M8 | 3.5 | 226 | 227 |
| | FF165/FT165 | 110 | 200 | 165 | 130 | 10.5 | M10 | 3.5 | 233 | 234 |
| 90 | FT85 | 127 | 105 | 85 | 70 | 7.5 | M6 | 2.5 | - | 218 |
| | FF100/FT100 | 127 | 120 | 100 | 80 | 7.5 | M6 | 3 | 220 | 219 |
| | FF115/FT115 | 127 | 140 | 115 | 95 | 9.5 | M8 | 3 | 223 | 224 |
| | FF130/FT130 | 127 | 160 | 130 | 110 | 9.5 | M8 | 3.5 | 226 | 227 |
| | FF165/FT165 | 127 | 200 | 165 | 130 | 10.5 | M10 | 3.5 | 233 | 234 |
| 100 | FF130/FT130 | 137 | 160 | 130 | 110 | 9.5 | M8 | 3.5 | 226 | 227 |
| | FF165/FT165 | 137 | 200 | 165 | 130 | 10.5 | M10 | 3.5 | 233 | 234 |
| | FF215/FT215 | 137 | 250 | 215 | 180 | 12.5 | M12 | 4 | 243 | 244 |
| 112 | FF130/FT130 | 137 | 160 | 130 | 110 | 9.5 | M8 | 3.5 | 226 | 227 |
| | FF165/FT165 | 137 | 200 | 165 | 130 | 10.5 | M10 | 3.5 | 233 | 234 |
| | FF215/FT215 | 137 | 250 | 215 | 180 | 12.5 | M12 | 4 | 243 | 244 |
| 132 | FF215/FT215 | 164 | 250 | 215 | 180 | 12.5 | M12 | 4 | 243 | 244 |
| | FF265/FT265 | 164 | 300 | 265 | 230 | 16 | M12 | 4 | 253 | 254 |

Tolerances

| | |
|---|--------|
| N | ISO j6 |
|---|--------|

Dimension drawings

Foot- and flange-mounted aluminum motors, 132

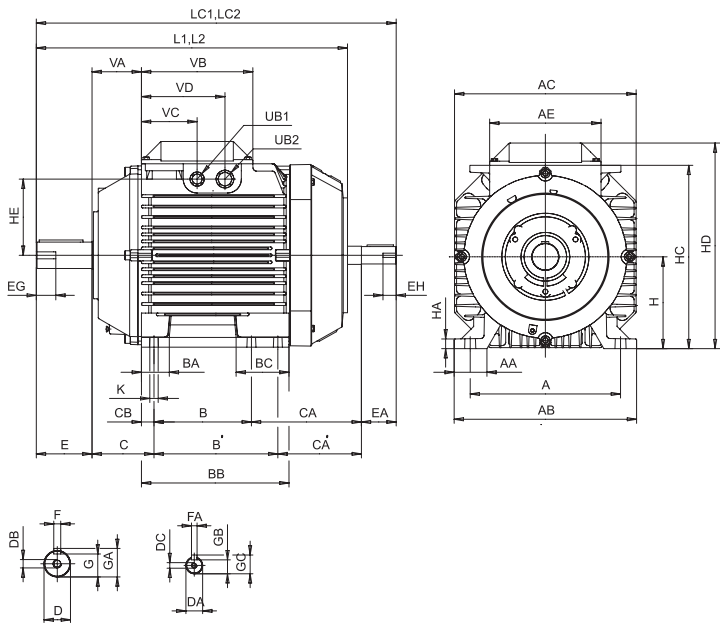

Foot-mounted motor; IM B3 (IM 1001), IM 1002

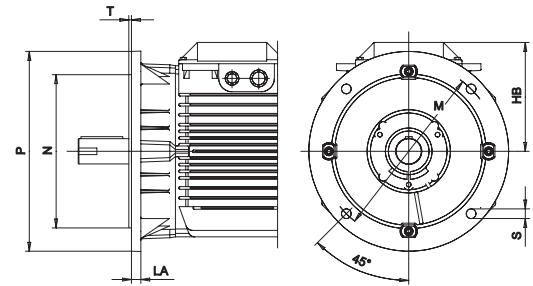

Flange-mounted motor, large flange; IM B5 (IM 3001), IM 3002

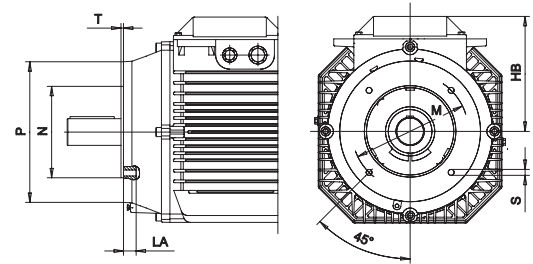

Flange-mounted motor, small flange; IM B14 (IM 3601), IM 3602

IM B3 (IM 1001), IM 1002

| Motor size | A | AA | AB | AC | AE | B | B' | BA | BB | BC | C | CA | CA' | CB | D | DA | DB | DC | E | EA | EG | EH | F |
|---------------------|-----|----|-----|-----|-----|-----|-----|----|-----|----|----|-----|-----|----|----|----|-----|----|----|----|----|----|----|
| 132 ¹⁾ | 216 | 47 | 262 | 261 | 160 | 140 | 178 | 40 | 212 | 76 | 89 | 158 | 120 | 18 | 38 | 24 | M12 | M8 | 80 | 50 | 28 | 19 | 10 |
| 132 ²⁾ | 216 | 47 | 262 | 261 | 160 | 140 | 178 | 40 | 212 | 76 | 89 | 178 | 140 | 18 | 38 | 24 | M12 | M8 | 80 | 50 | 28 | 19 | 10 |
| 132 SM ₋ | 216 | 47 | 262 | 261 | 160 | 140 | 178 | 40 | 212 | 76 | 89 | 261 | 223 | 18 | 38 | 24 | M12 | M8 | 80 | 50 | 28 | 19 | 10 |

| Motor size | FA | G | GA | GB | GC | H | HA | HC | HD | HE | K | KA | L | LC | UB1 | UB2 | UD | VA | VB | VC | VD | VE |
|---------------------|----|----|----|----|----|-----|----|-------|-------|-------|----|----|-----|-----|-----|-----|-----|----|-----|----|-----|-----|
| 132 ¹⁾ | 8 | 33 | 41 | 20 | 27 | 132 | 14 | 263.5 | 295.5 | 109.5 | 12 | 15 | 447 | 517 | M20 | M25 | - | 71 | 160 | 80 | 120 | |
| 132 ²⁾ | 8 | 33 | 41 | 20 | 27 | 132 | 14 | 263.5 | 295.5 | 109.5 | 12 | 15 | 487 | 537 | M20 | M25 | - | 71 | 160 | 80 | 120 | |
| 132 SM ₋ | 8 | 33 | 41 | 20 | 27 | 132 | 14 | 287 | 321 | 123.5 | 12 | 15 | 550 | 620 | M40 | M32 | M12 | 71 | 160 | 42 | 102 | 136 |

IM B5 (IM 3001), IM 3002

IM B14 (IM 3601), 3602

| Motor size | HB | LA | M | N | P | S | T | Motor size | HB | LA | M | N | P | S | T |
|---------------------|-------|----|-----|-----|-----|------|---|---------------------|-------|------|-----|-----|-----|-----|-----|
| 132 ¹⁾ | 163.5 | 14 | 265 | 230 | 300 | 14.5 | 4 | 132 ¹⁾ | 163.5 | 14.5 | 165 | 130 | 200 | M10 | 3.5 |
| 132 ²⁾ | 163.5 | 14 | 265 | 230 | 300 | 14.5 | 4 | 132 ²⁾ | 163.5 | 14.5 | 165 | 130 | 200 | M10 | 3.5 |
| 132 SM ₋ | 189 | 14 | 265 | 230 | 300 | 14.5 | 4 | 132 SM ₋ | 189 | 14.5 | 165 | 130 | 200 | M10 | 3.5 |

Tolerances

| | |
|-------|----------|
| A, B | ISO js14 |
| C, CA | +2 -2 |
| D | ISO k6 |
| DA | ISO j6 |
| F, FA | ISO h9 |
| H | +0 -0.5 |
| N | ISO j6 |

Footnotes

- ¹⁾ IE2: SB-2, M-4, MA-4, MBA-4
 IE3: M-4, MA-4, S-6
²⁾ IE2: SC-2, MC-6
 IE3: SB-2, SC-2, MA-6, MC-6

Dimension drawings

Foot- and flange-mounted aluminum motors, 132

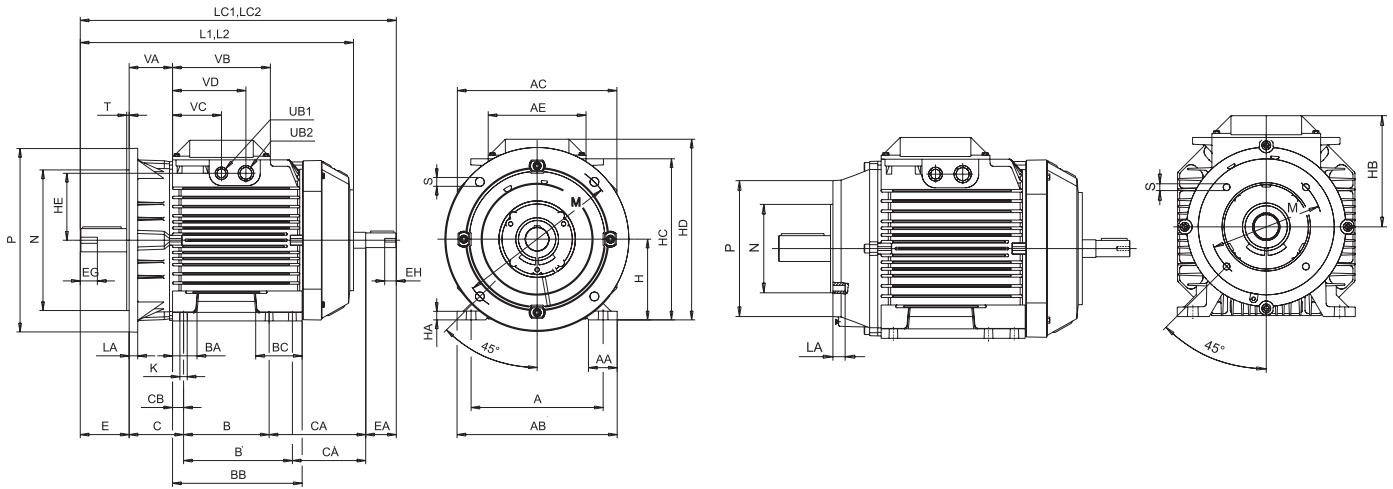

Foot- and flange-mounted motor; IM B35 (IM 2001), IM 2002, large flange

Foot- and flange-mounted motor; IM B34 (IM 2101), IM 2102, small flange

IM B3 (IM 2001), IM 2002

| Motor size | A | AA | AB | AC | AE | B | B' | BA | BB | BC | C | CA | CA' | CB | D | DA | DB | DC | E | EA | EG | EH | F |
|------------|-----|----|-----|-----|-----|-----|-----|----|-----|----|----|-----|-----|----|----|----|-----|----|----|----|----|----|----|
| 132 1) | 216 | 47 | 262 | 261 | 160 | 140 | 178 | 40 | 212 | 76 | 89 | 158 | 120 | 18 | 38 | 24 | M12 | M8 | 80 | 50 | 28 | 19 | 10 |
| 132 2) | 216 | 47 | 262 | 261 | 160 | 140 | 178 | 40 | 212 | 76 | 89 | 178 | 140 | 18 | 38 | 24 | M12 | M8 | 80 | 50 | 28 | 19 | 10 |
| 132 SM_ | 216 | 47 | 262 | 261 | 160 | 140 | 178 | 40 | 212 | 76 | 89 | 261 | 223 | 18 | 38 | 24 | M12 | M8 | 80 | 50 | 28 | 19 | 10 |

| Motor size | FA | G | GA | GB | GC | H | HA | HC | HD | HE | K | KA | L | LC | UB1 | UB2 | UD | VA | VB | VC | VD | VE |
|------------|----|----|----|----|----|-----|----|-------|-------|-------|----|----|-----|-----|-----|-----|-----|----|-----|----|-----|-----|
| 132 1) | 8 | 33 | 41 | 20 | 27 | 132 | 14 | 263.5 | 295.5 | 109.5 | 12 | 15 | 447 | 517 | M20 | M25 | - | 71 | 160 | 80 | 120 | |
| 132 2) | 8 | 33 | 41 | 20 | 27 | 132 | 14 | 263.5 | 295.5 | 109.5 | 12 | 15 | 487 | 537 | M20 | M25 | - | 71 | 160 | 80 | 120 | |
| 132 SM_ | 8 | 33 | 41 | 20 | 27 | 132 | 14 | 287 | 321 | 123.5 | 12 | 15 | 550 | 620 | M40 | M32 | M12 | 71 | 160 | 42 | 102 | 136 |

IM B35 (IM 2001)

IM B34 (IM 2101)

| Motor size | HB | LA | M | N | P | S | T | Motor size | HB | LA | M | N | P | S | T |
|-------------------|-------|----|-----|-----|-----|------|---|-------------------|-------|------|-----|-----|-----|-----|-----|
| 132 ¹⁾ | 163.5 | 14 | 265 | 230 | 300 | 14.5 | 4 | 132 ¹⁾ | 163.5 | 14.5 | 165 | 130 | 200 | M10 | 3.5 |
| 132 ²⁾ | 163.5 | 14 | 265 | 230 | 300 | 14.5 | 4 | 132 ²⁾ | 163.5 | 14.5 | 165 | 130 | 200 | M10 | 3.5 |
| 132 SM_ | 189 | 14 | 265 | 230 | 300 | 14.5 | 4 | 132 SM_ | 189 | 14.5 | 165 | 130 | 200 | M10 | 3.5 |

Tolerances

| | |
|-------|----------|
| A, B | ISO js14 |
| C, CA | +2 -2 |
| D | ISO k6 |
| DA | ISO j6 |
| F, FA | ISO h9 |
| H | +0 -0.5 |
| N | ISO j6 |

Footnotes

| |
|-------------------------------------------|
| ¹⁾ IE2: SB-2, M-4, MA-4, MBA-4 |
| IE3: M-4, MA-4, S-6 |
| ²⁾ IE2: SC-2, MC-6 |
| IE3: SB-2, SC-2, MA-6, MC-6 |

Dimension drawings

Foot-mounted aluminum motors, 160 - 180

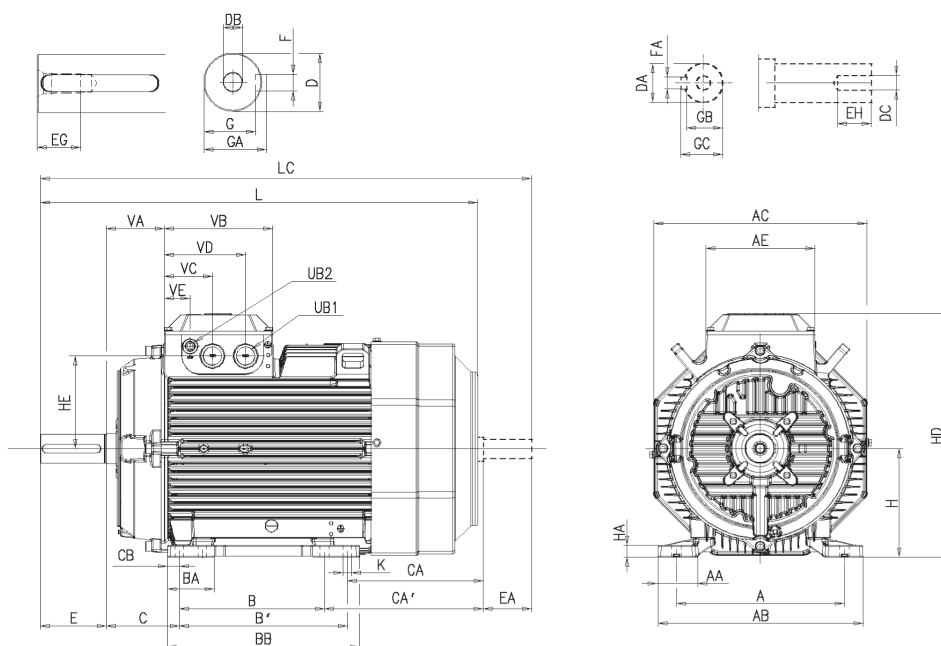

Foot-mounted motor; IM B3 (IM 1001), IM 1002

IM B3 (IM 1001), IM 1002

| Motor size | A | AA | AB | AC | AE | B | B' | BA | BB | C | CA | CA' | CB | D | DA | DB | DC | E | EA |
|-------------------|-----|----|-----|-----|-----|-----|-----|----|-----|-----|-----|-----|----|----|----|-----|-----|-----|----|
| 160 ¹⁾ | 254 | 54 | 310 | 323 | 180 | 210 | 254 | 84 | 294 | 108 | 172 | 128 | 20 | 42 | 32 | M16 | M12 | 110 | 80 |
| 160 ²⁾ | 254 | 54 | 310 | 323 | 180 | 210 | 254 | 84 | 294 | 108 | 269 | 225 | 20 | 42 | 32 | M16 | M12 | 110 | 80 |
| 180 | 279 | 68 | 341 | 354 | 180 | 241 | 279 | 78 | 319 | 121 | 263 | 225 | 20 | 48 | 32 | M16 | M12 | 110 | 80 |
| 180 ⁴⁾ | 279 | 66 | 340 | 311 | 180 | 241 | 279 | 78 | 319 | 121 | 238 | 200 | 20 | 48 | 32 | M16 | M12 | 110 | 80 |

| Motor size | EG | EH | F | FA | G | GA | GB | GC | H | HA | HC | HD | HE | K | L | LC | UB1 ³⁾ | UB2 ³⁾ | VA |
|-------------------|----|----|----|----|------|------|----|----|-----|----|-----|-----|-----|------|-----|-----|-------------------|-------------------|------|
| 160 ¹⁾ | 36 | 28 | 12 | 10 | 37 | 45 | 27 | 35 | 160 | 20 | 342 | 370 | 139 | 15 | 584 | 680 | 2*M40 | M16 | 88.5 |
| 160 ²⁾ | 36 | 28 | 12 | 10 | 37 | 45 | 27 | 35 | 160 | 20 | 342 | 370 | 139 | 15 | 681 | 777 | 2*M40 | M16 | 88.5 |
| 180 | 36 | 28 | 14 | 10 | 42.5 | 51.5 | 27 | 35 | 180 | 20 | 369 | 405 | 154 | 15 | 726 | 815 | 2*M40 | M16 | 88.5 |
| 180 ⁴⁾ | 36 | 28 | 14 | 10 | 42.5 | 51.5 | 27 | 35 | 180 | 20 | - | 390 | 139 | 14.5 | 681 | 777 | 2*M40 | M16 | 88.5 |

| Motor size | VB | VC | VD | VE |
|-------------------|-----|----|-------|----|
| 160 ¹⁾ | 180 | 80 | 135.5 | 43 |
| 160 ²⁾ | 180 | 80 | 135.5 | 43 |
| 180 | 180 | 80 | 135.5 | 43 |
| 180 ⁴⁾ | 180 | 80 | 135.5 | 43 |

| Tolerances | Footnotes |
|------------|--------------------------------------------------------------------------------------|
| A, B | ISO js14 |
| C, CA | ± 0.8 |
| D, DA | ISO k6 |
| F, FA | ISO h9 |
| H | +0 -0.5 |
| | M3AA IE2: |
| | ¹⁾ MLA-2, MLB-2, MLA-4, MLA-6, MLA-8 and MLB 8-poles |
| | ²⁾ MLC-2, MLD-2, MLE-2, MLB-4, MLC-4, MLD-4, MLB-6, MLC-6 and MLC-8 poles |
| | M3AA IE3: |
| | ¹⁾ MLA-2 |
| | ²⁾ MLB-2, MLC-2, all 4- and 6-poles |
| | ³⁾ Knock-out openings |
| | ⁴⁾ L generation |

Dimension drawings

Flange-mounted aluminum motors, 160 - 180

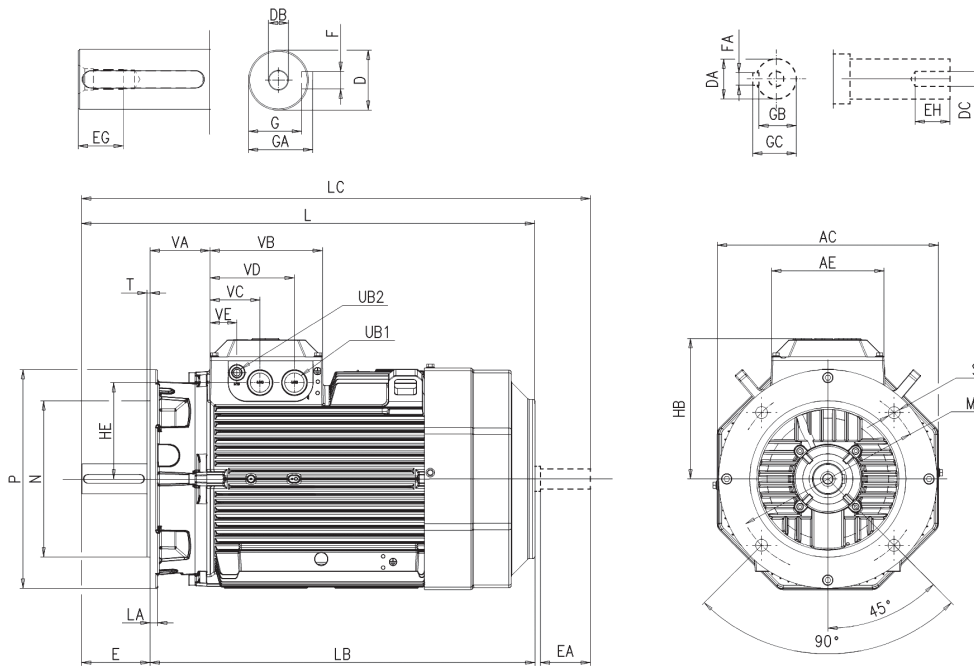

Flange-mounted motor; IM B5 (IM 3001), IM 3002

IM B5 (IM 3001), IM 3002

| Motor size | AC | AE | D | DA | DB | DC | E ⁴⁾ | EA | EG | EH | F | FA | G | GA | GB | GC | HB |
|-------------------|-----|-----|----|----|-----|-----|-----------------|----|----|----|----|----|------|------|----|----|-----|
| 160 ¹⁾ | 323 | 180 | 42 | 32 | M16 | M12 | 110 | 80 | 36 | 28 | 12 | 10 | 37 | 45 | 27 | 35 | 210 |
| 160 ²⁾ | 323 | 180 | 42 | 32 | M16 | M12 | 110 | 80 | 36 | 28 | 12 | 10 | 37 | 45 | 27 | 35 | 210 |
| 180 | 354 | 180 | 48 | 32 | M16 | M12 | 110 | 80 | 36 | 28 | 14 | 10 | 42.5 | 51.5 | 27 | 35 | 225 |
| 180 ³⁾ | 311 | 180 | 48 | 32 | M16 | M12 | 110 | 80 | 36 | 28 | 14 | 10 | 42.5 | 51.5 | 27 | 35 | 210 |

| Motor size | HE | L | LA | LB | LC | M | N | P | S | T | UB1 ³⁾ | UB2 ³⁾ | VA | VB | VC | VD | VE |
|-------------------|-----|-----|----|-----|-----|-----|-----|-----|----|---|-------------------|-------------------|------|-----|----|----|-------|
| 160 ¹⁾ | 139 | 584 | 20 | 474 | 680 | 300 | 250 | 350 | 19 | 5 | 2*M40 | M16 | 88.5 | 180 | 43 | 80 | 135.5 |
| 160 ²⁾ | 139 | 681 | 20 | 571 | 777 | 300 | 250 | 350 | 19 | 5 | 2*M40 | M16 | 88.5 | 180 | 43 | 80 | 135.5 |
| 180 | 154 | 726 | 15 | 616 | 815 | 300 | 250 | 350 | 19 | 5 | 2*M40 | M16 | 88.5 | 180 | 43 | 80 | 135.5 |
| 180 ³⁾ | 139 | 681 | 18 | 571 | 777 | 300 | 250 | 350 | 19 | 5 | 2*M40 | M16 | 88.5 | 180 | 43 | 80 | 135.5 |

Tolerances

| | |
|-------|--------|
| D, DA | ISO k6 |
| F, FA | ISO h9 |
| N | ISO j6 |

Footnotes

- M3AA IE2:**
- 1) MLA-2, MLB-2, MLA-4, MLA-6, MLA-8 and MLB 8-poles
 - 2) MLC-2, MLD-2, MLE-2, MLB-4, MLC-4, MLD-4, MLB-6, MLC-6 and MLC-8 poles
- M3AA IE3:**
- 1) MLA-2
 - 2) MLB-2, MLC-2, all 4- and 6-poles
 - 3) Knock-out openings
 - 4) Shoulder of shaft extension and contact surface of flange are in the same plane.
 - 5) L generation

Dimension drawings

Foot- and flange-mounted aluminum motors, 160 - 180

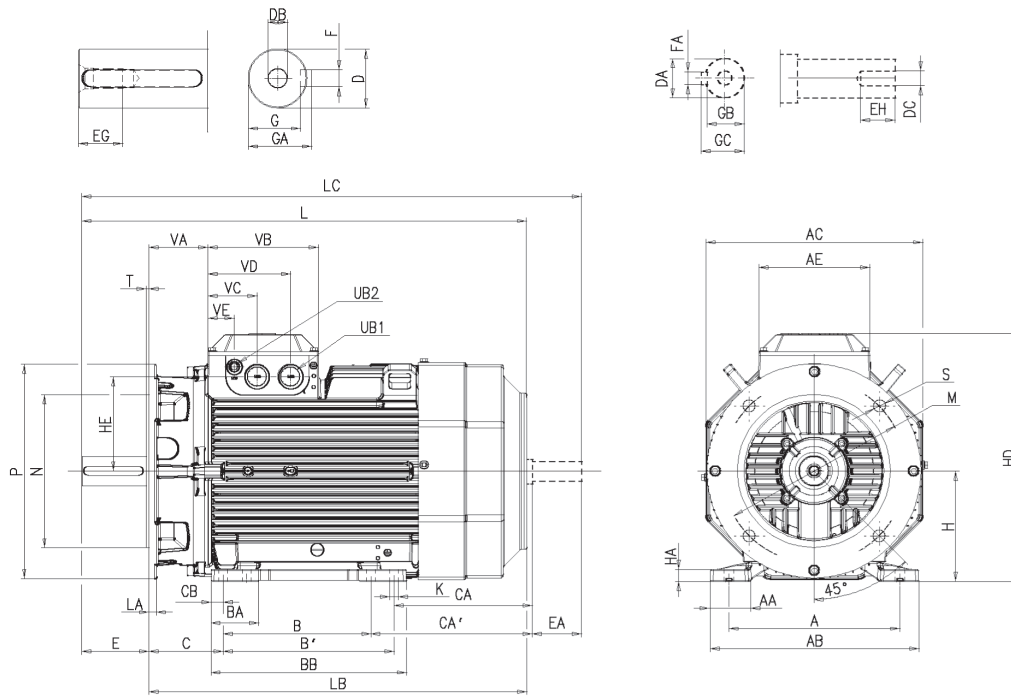

IM B35 (IM 2001), IM 2002

| Motor size | A | AA | AB | AC | AE | B | B' | BA | BB | C | CA | CA' | CB | D | DA | DB | DC | E ⁴⁾ | EA |
|-------------------|-----|----|-----|-----|-----|-----|-----|----|-----|-----|-----|-----|----|----|----|-----|-----|-----------------|----|
| 160 ¹⁾ | 254 | 54 | 310 | 323 | 180 | 210 | 254 | 84 | 294 | 108 | 172 | 128 | 20 | 42 | 32 | M16 | M12 | 110 | 80 |
| 160 ²⁾ | 254 | 54 | 310 | 323 | 180 | 210 | 254 | 84 | 294 | 108 | 269 | 225 | 20 | 42 | 32 | M16 | M12 | 110 | 80 |
| 180 | 279 | 68 | 341 | 354 | 180 | 241 | 279 | 78 | 319 | 121 | 263 | 225 | 20 | 48 | 32 | M16 | M12 | 110 | 80 |
| 180 ³⁾ | 279 | 66 | 340 | 311 | 180 | 241 | 279 | 78 | 319 | 121 | 238 | 200 | 20 | 48 | 32 | M16 | M12 | 110 | 80 |

| Motor size | EG | EH | F | FA | G | GA | GB | GC | H | HA | HC | HD | HE | K | L | LA | LB | LC | M |
|-------------------|----|----|----|----|------|------|----|----|-----|----|-----|-----|-----|------|-----|----|-----|-----|-----|
| 160 ¹⁾ | 36 | 28 | 12 | 10 | 37 | 45 | 27 | 35 | 160 | 20 | 342 | 370 | 139 | 14.5 | 584 | 20 | 474 | 680 | 300 |
| 160 ²⁾ | 36 | 28 | 12 | 10 | 37 | 45 | 27 | 35 | 160 | 20 | 342 | 370 | 139 | 14.5 | 681 | 20 | 571 | 777 | 300 |
| 180 | 36 | 28 | 14 | 10 | 42.5 | 51.5 | 27 | 35 | 180 | 20 | 369 | 405 | 154 | 14.5 | 726 | 15 | 616 | 815 | 300 |
| 180 ³⁾ | 36 | 28 | 14 | 10 | 42.5 | 51.5 | 27 | 35 | 180 | 20 | - | 390 | 139 | 14.5 | 681 | 18 | 571 | 777 | 300 |

| Motor size | N | P | S | T | UB1 ³⁾ | UB2 ³⁾ | VA | VB | VC | VD | VE |
|-------------------|-----|-----|----|---|-------------------|-------------------|------|-----|----|-------|----|
| 160 ¹⁾ | 250 | 350 | 19 | 5 | 2*M40 | M16 | 88.5 | 180 | 80 | 135.5 | 43 |
| 160 ²⁾ | 250 | 350 | 19 | 5 | 2*M40 | M16 | 88.5 | 180 | 80 | 135.5 | 43 |
| 180 | 250 | 350 | 19 | 5 | 2*M40 | M16 | 88.5 | 180 | 80 | 135.5 | 43 |
| 180 ³⁾ | 250 | 350 | 19 | 5 | 2*M40 | M16 | 88.5 | 180 | 80 | 135.5 | 43 |

Tolerances

| | |
|-------|----------|
| A, B | ISO js14 |
| C, CA | ±8 |
| D, DA | ISO k6 |
| F, FA | ISO h9 |
| H | +0 - 0.5 |
| N | ISO j6 |

Footnotes

- M3AA IE2:**
- 1) MLA-2, MLB-2, MLA-4, MLA-6, MLA-8 and MLB 8-poles
 - 2) MLC-2, MLD-2, MLE-2, MLB-4, MLC-4, MLD-4, MLB-6, MLC-6 and MLC-8 poles
- M3AA IE3:**
- 1) MLA-2
 - 2) MLB-2, MLC-2, all 4- and 6-poles
 - 3) Knock-out openings
 - 4) Shoulder of shaft extension and contact surface of flange are in same plane.
 - 5) L generation

Dimension drawings

Foot-mounted aluminum motors, 200 - 225

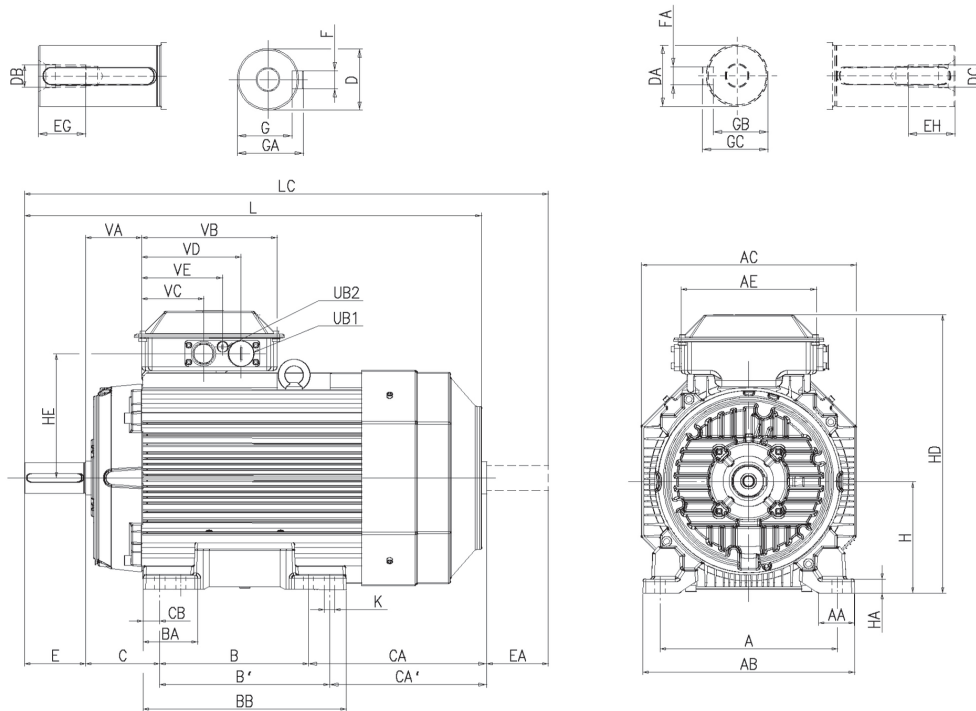

Foot-mounted motor; IM B3 (IM 1001), IM 1002

IM B3 (IM 1001), IM 1002

| Motor size | Poles | A | AA | AB | AC | AE | B | B' | BA | BB | C | CA | CA' | CB | D | DA | DB | DC | E | EA |
|------------|-------|-----|----|-----|-----|-----|-----|-----|-----|-----|-----|-----|-----|------|----|----|-----|-----|-----|-----|
| 200 | | 318 | 64 | 380 | 386 | 243 | 267 | 305 | 112 | 365 | 133 | 314 | 276 | 30 | 55 | 45 | M20 | M16 | 110 | 110 |
| 225 | 2 | 356 | 69 | 418 | 425 | 243 | 286 | 311 | 102 | 365 | 149 | 314 | 289 | 24.5 | 55 | 55 | M20 | M20 | 110 | 110 |
| 225 | 4-8 | 356 | 69 | 418 | 425 | 243 | 286 | 311 | 102 | 365 | 149 | 314 | 289 | 24.5 | 60 | 55 | M20 | M20 | 140 | 110 |

| Motor size | Poles | EG | EH | F | FA | G | GA | GB | GC | H | HA | HD ²⁾ | HD ³⁾ | HE ²⁾ | HE ³⁾ | K | L | LC | UB ¹⁾ |
|------------|-------|----|----|----|----|----|----|------|------|-----|----|------------------|------------------|------------------|------------------|----|-----|------|------------------|
| 200 | | 42 | 36 | 16 | 14 | 49 | 59 | 39.5 | 48.5 | 200 | 25 | 500 | 532 | 224 | 239 | 18 | 821 | 934 | 2xFL13 |
| 225 | 2 | 42 | 42 | 16 | 14 | 49 | 59 | 49 | 59 | 225 | 25 | 547 | 579 | 244.5 | 260 | 18 | 850 | 971 | 2xFL13 |
| 225 | 4-8 | 42 | 42 | 18 | 16 | 53 | 64 | 49 | 59 | 225 | 25 | 547 | 579 | 244.5 | 260 | 18 | 880 | 1001 | 2xFL13 |

| Motor size | Poles | VA | VB | VC ²⁾ | VC ³⁾ | VD ²⁾ | VD ³⁾ | VE ²⁾ | VE ³⁾ |
|------------|-------|------|-----|------------------|------------------|------------------|------------------|------------------|------------------|
| 200 | | 101 | 243 | 112 | 77 | 179 | 167 | 145 | 122 |
| 225 | 2 | 93.5 | 243 | 112 | 77 | 179 | 167 | 145 | 122 |
| 225 | 4-8 | 93.5 | 243 | 112 | 77 | 179 | 167 | 145 | 122 |

Tolerances

Footnotes

| | | |
|----------|----------|-------------------------------------------------------------------------------------------------------------------------------------------------------------------------------------------------------------------------------------------------------------------------------------------------------------------------------------------------------------------------------------------------|
| A, B | ISO js14 | ¹⁾ Flange opening is provided with pipe flange FL 13, with tapped lead-in holes plugged with sealing plugs. Single- and two-speed motors: 2 x M40 + M16. Motors for 230V 50Hz or 225 SMC-2, 225 SMD-2, 225 SMD-4 have pipe flange FL21 and 2 x M63 + M16 ²⁾ For flange opening FL13: 2 x M40 + M16 ³⁾ For extra large flange opening FL21: 2 x M63 + M16 |
| C, CA | ± 0.8 | |
| D 55-65 | ISO m6 | |
| DA 45-55 | ISO k6 | |
| F, FA | ISO h9 | |
| H | +0 -0.5 | |

Dimension drawings

Foot-mounted aluminum motors, 200 - 225, IE3 L generation

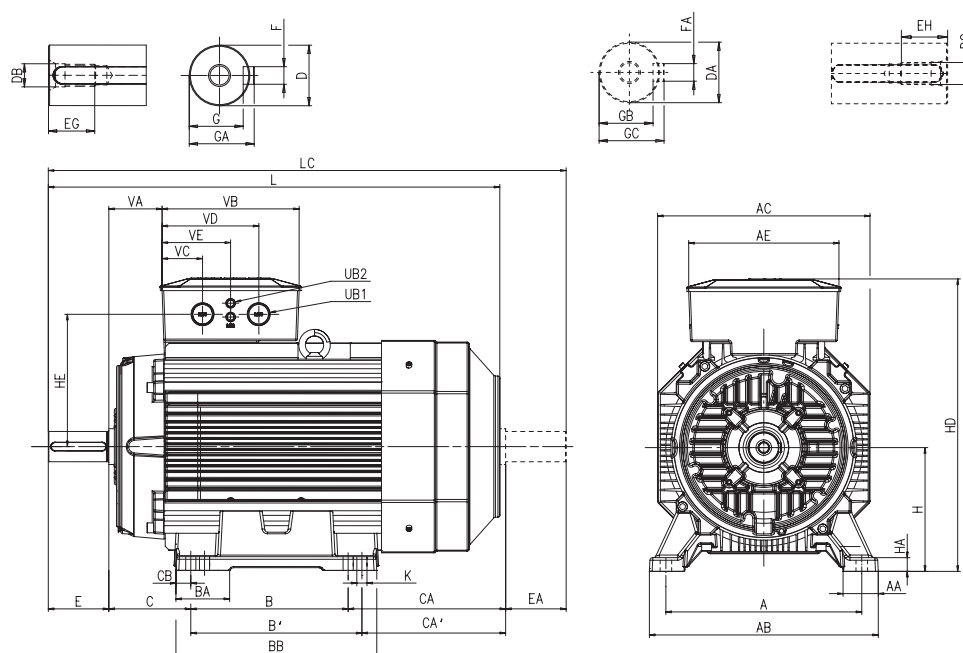

IM B3 (IM 1001), IM 1002

| Motor size | Poles | Voltage code | A | AA | AB | AC | AE | B | B' | BA | BB | C | CA | CA' | CB | D | DA | DB | DC | E | EA |
|------------|-------|--------------|-----|----|-----|-----|-----|-----|-----|-----|-----|-----|-----|-----|----|----|----|-----|-----|-----|-----|
| 200 | | | 318 | 87 | 382 | 386 | 180 | 267 | 305 | 103 | 365 | 133 | 237 | 199 | 30 | 55 | 45 | M20 | M16 | 110 | 80 |
| 225 | 2 | D, E | 356 | 64 | 416 | 386 | 273 | 286 | 311 | 98 | 365 | 149 | 287 | 262 | 27 | 55 | 55 | M20 | M20 | 110 | 110 |
| 225 | 4-6 | D, E | 356 | 64 | 416 | 386 | 273 | 286 | 311 | 98 | 365 | 149 | 287 | 262 | 27 | 60 | 55 | M20 | M20 | 140 | 110 |
| 225 | 2 | S | 356 | 64 | 416 | 386 | 273 | 286 | 311 | 98 | 365 | 149 | 287 | 262 | 27 | 55 | 55 | M20 | M20 | 110 | 110 |
| 225 | 4-6 | S | 356 | 64 | 416 | 386 | 273 | 286 | 311 | 98 | 365 | 149 | 287 | 262 | 27 | 60 | 55 | M20 | M20 | 140 | 110 |

| Motor size | Poles | Voltage code | EG | EH | F | FA | G | GA | GB | GC | H | HA | HD | HE | K | L | LC | UB1 | UB2 |
|------------|-------|--------------|----|----|----|----|----|----|------|------|-----|----|-----|-----|----|-----|-----|-------|-------|
| 200 | | | 42 | 36 | 16 | 14 | 49 | 59 | 39,5 | 48,5 | 200 | 25 | 425 | 154 | 15 | 726 | 815 | 2*M40 | M16 |
| 225 | 2 | D, E | 42 | 42 | 16 | 14 | 49 | 59 | 49 | 59 | 225 | 25 | 531 | 241 | 18 | 821 | 942 | 2*M40 | 2*M16 |
| 225 | 4-6 | D, E | 42 | 42 | 18 | 16 | 53 | 64 | 49 | 59 | 225 | 25 | 531 | 241 | 18 | 851 | 972 | 2*M40 | 2*M16 |
| 225 | 2 | S | 42 | 42 | 16 | 14 | 49 | 59 | 49 | 59 | 225 | 25 | 531 | 241 | 18 | 821 | 942 | 2*M63 | 2*M16 |
| 225 | 4-6 | S | 42 | 42 | 18 | 16 | 53 | 64 | 49 | 59 | 225 | 25 | 531 | 241 | 18 | 851 | 972 | 2*M63 | 2*M16 |

| Motor size | Poles | Voltage code | VA | VB | VC | VD | VE |
|------------|-------|--------------|------|-----|------|-------|-------|
| 200 | | | 88,5 | 180 | 80 | 135,5 | 43 |
| 225 | 2 | D, E | 97 | 249 | 73,5 | 175,5 | 124,5 |
| 225 | 4-6 | D, E | 97 | 249 | 73,5 | 175,5 | 124,5 |
| 225 | 2 | S | 97 | 249 | 73,5 | 175,5 | 124,5 |
| 225 | 4-6 | S | 97 | 249 | 73,5 | 175,5 | 124,5 |

Tolerances

| | |
|----------|----------|
| A, B | ISO js14 |
| C, CA | ± 0.8 |
| D 55-65 | ISO m6 |
| DA 45-55 | ISO k6 |
| F, FA | ISO h9 |
| H | +0 -0.5 |

Dimension drawings

Flange-mounted aluminum motors, 200 - 225

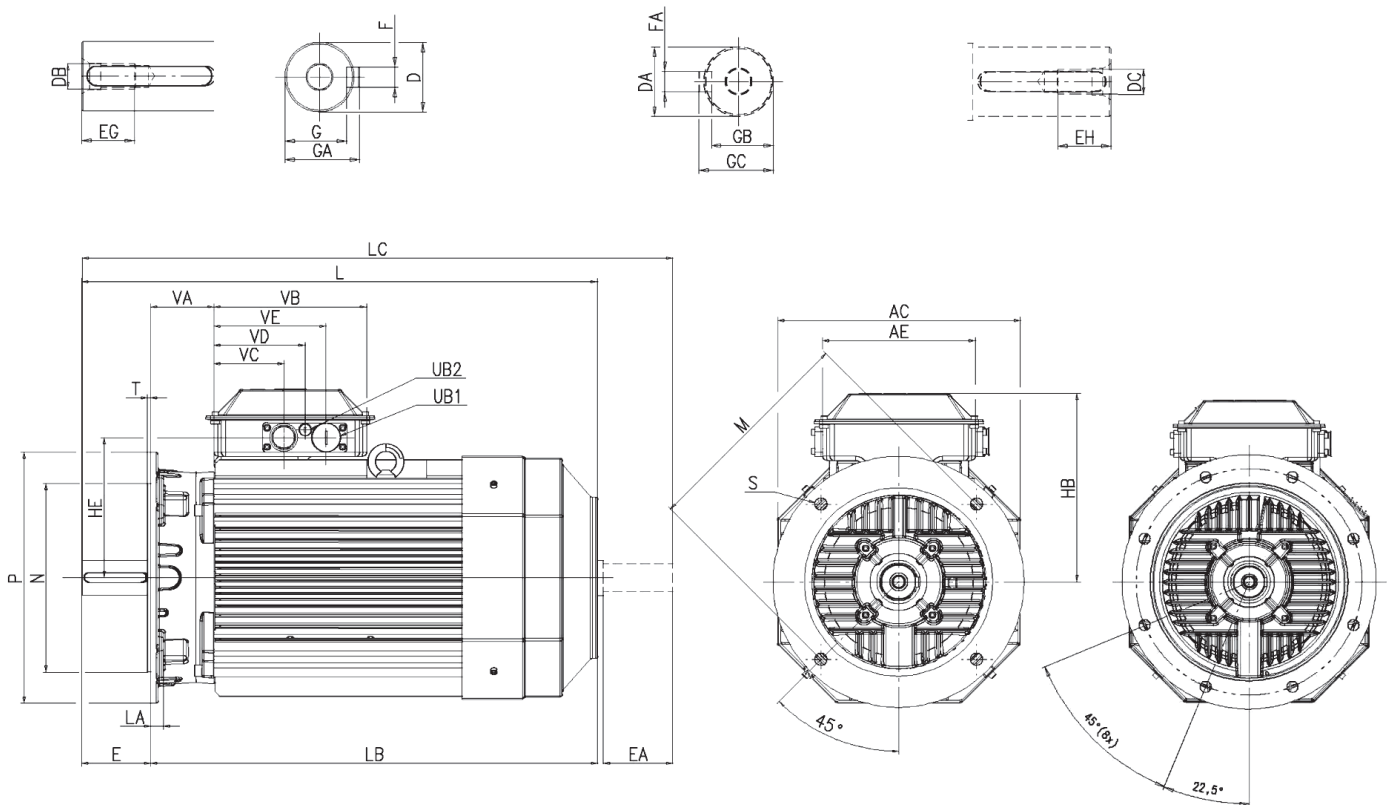

Flange-mounted motor; IM B5 (IM 3001), IM 3002 M3AA 200 M3AA 225

IM B5 (IM 3001), IM 3002

| Motor size | Poles | AC | AE | D | DA | DB | DC | E ¹⁾ | EA | EG | EH | F | FA | G | GA | GB | GC | HB ³⁾ | HB ⁴⁾ | HE ³⁾ |
|------------|-------|-----|-----|----|----|-----|-----|-----------------|-----|----|----|----|----|----|----|------|------|------------------|------------------|------------------|
| 200 | | 386 | 243 | 55 | 45 | M20 | M16 | 110 | 110 | 42 | 36 | 14 | 16 | 49 | 59 | 39.5 | 48.5 | 300 | 332 | 224 |
| 225 | 2 | 425 | 243 | 55 | 55 | M20 | M20 | 110 | 110 | 42 | 42 | 16 | 16 | 49 | 59 | 49 | 59 | 300 | 332 | 244 |
| 225 | 4-8 | 425 | 243 | 60 | 55 | M20 | M20 | 140 | 110 | 42 | 42 | 16 | 16 | 53 | 64 | 49 | 59 | 322 | 354 | 244 |

| Motor size | Poles | HE ³⁾ | L | LA | LB | LC | M | N | P | S | T | UB ²⁾ | VA | VB | VC ³⁾ | VC ⁴⁾ | VD ³⁾ | VD ⁴⁾ | VE ³⁾ | VE ⁴⁾ |
|------------|-------|------------------|-----|----|-----|------|-----|-----|-----|----|---|------------------|------|-----|------------------|------------------|------------------|------------------|------------------|------------------|
| 200 | | 239 | 821 | 20 | 711 | 934 | 350 | 300 | 400 | 19 | 5 | 2xFL13 | 101 | 243 | 112 | 77 | 179 | 167 | 145 | 122 |
| 225 | 2 | 260 | 850 | 22 | 740 | 971 | 400 | 350 | 450 | 19 | 5 | 2xFL13 | 93.5 | 243 | 112 | 77 | 179 | 167 | 145 | 122 |
| 225 | 4-8 | 260 | 880 | 22 | 740 | 1001 | 400 | 350 | 450 | 19 | 5 | 2xFL13 | 93.5 | 243 | 112 | 77 | 179 | 167 | 145 | 122 |

Tolerances

| | |
|----------|--------|
| D 55-65 | ISO m6 |
| DA 45-55 | ISO k6 |
| F, FA | ISO h9 |
| N | ISO j6 |

Footnotes

- ¹⁾ Shoulder of shaft extension and contact surface of flange are in the same plane.
- ²⁾ Flange opening is provided with pipe flange FL 13, with tapped lead-in holes plugged with sealing plugs. Single- and two-speed motors: 2 x M40 + M16. Motors for 230VD 50Hz or 225 SMC-2, 225 SMD-2, 225 SMD-4 have pipe flange FL21 and 2 x M63 + M16
- ³⁾ For flange opening FL13: 2 x M40 + M16
- ⁴⁾ For extra large flange opening FL21: 2 x M63 + M16

Dimension drawings

Flange-mounted aluminum motors, 200 - 225, IE3 L generation

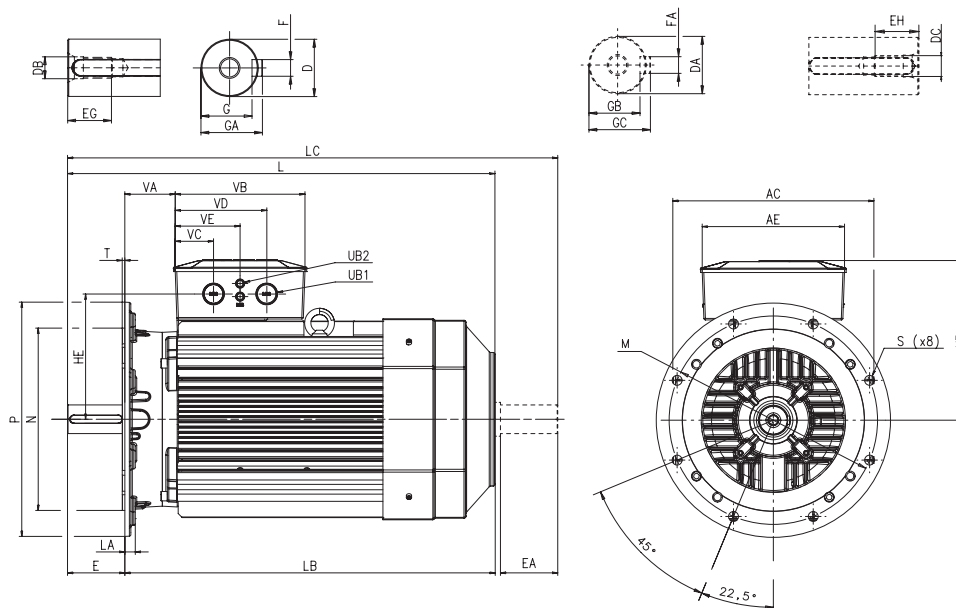

IM B5 (IM 3001), IM 3002

| Motor size | Poles | Voltage code | AC | AE | D | DA | DB | DC | E | EA | EG | EH | F | FA | G | GA | GB | GC | HB |
|------------|-------|--------------|-----|-----|----|----|-----|-----|-----|-----|----|----|----|----|----|----|------|------|-----|
| 200 | | | 386 | 180 | 55 | 45 | M20 | M16 | 110 | 80 | 42 | 36 | 16 | 14 | 49 | 59 | 39,5 | 48,5 | 225 |
| 225 | 2 | D, E | 386 | 273 | 55 | 55 | M20 | M20 | 110 | 110 | 42 | 42 | 16 | 14 | 49 | 59 | 49 | 59 | |
| 225 | 4-6 | D, E | 386 | 273 | 60 | 55 | M20 | M20 | 140 | 110 | 42 | 42 | 18 | 16 | 53 | 64 | 49 | 59 | |
| 225 | 2 | S | 386 | 273 | 55 | 55 | M20 | M20 | 110 | 110 | 42 | 42 | 16 | 14 | 49 | 59 | 49 | 59 | |
| 225 | 4-6 | S | 386 | 273 | 60 | 55 | M20 | M20 | 140 | 110 | 42 | 42 | 18 | 16 | 53 | 64 | 49 | 59 | |

| Motor size | Poles | Voltage code | HE | L | LA | LB | LC | M | N | P | S | T | UB1 | UB2 | VA | VB | VC | VD | VE |
|------------|-------|--------------|-----|-----|----|-----|-----|-----|-----|-----|----|---|-------|-------|------|-----|------|-------|-------|
| 200 | | | 154 | 726 | 20 | 616 | 815 | 300 | 250 | 350 | 19 | 5 | 2*M40 | M16 | 88,5 | 180 | 80 | 135,5 | 43 |
| 225 | 2 | D, E | 241 | 821 | 20 | 711 | 942 | 400 | 350 | 450 | 19 | 5 | 2*M40 | 2*M16 | 97 | 249 | 73,5 | 175,5 | 124,5 |
| 225 | 4-6 | D, E | 241 | 851 | 20 | 711 | 972 | 400 | 350 | 450 | 19 | 5 | 2*M40 | 2*M16 | 97 | 249 | 73,5 | 175,5 | 124,5 |
| 225 | 2 | S | 241 | 821 | 20 | 711 | 942 | 400 | 350 | 450 | 19 | 5 | 2*M63 | 2*M16 | 97 | 249 | 73,5 | 175,5 | 124,5 |
| 225 | 4-6 | S | 241 | 851 | 20 | 711 | 972 | 400 | 350 | 450 | 19 | 5 | 2*M63 | 2*M16 | 97 | 249 | 73,5 | 175,5 | 124,5 |

Tolerances

| | |
|----------|--------|
| D 55-65 | ISO m6 |
| DA 45-55 | ISO k6 |
| F, FA | ISO h9 |
| N | ISO j6 |

Dimension drawings

Foot- and flange-mounted aluminum motors, 200 - 225

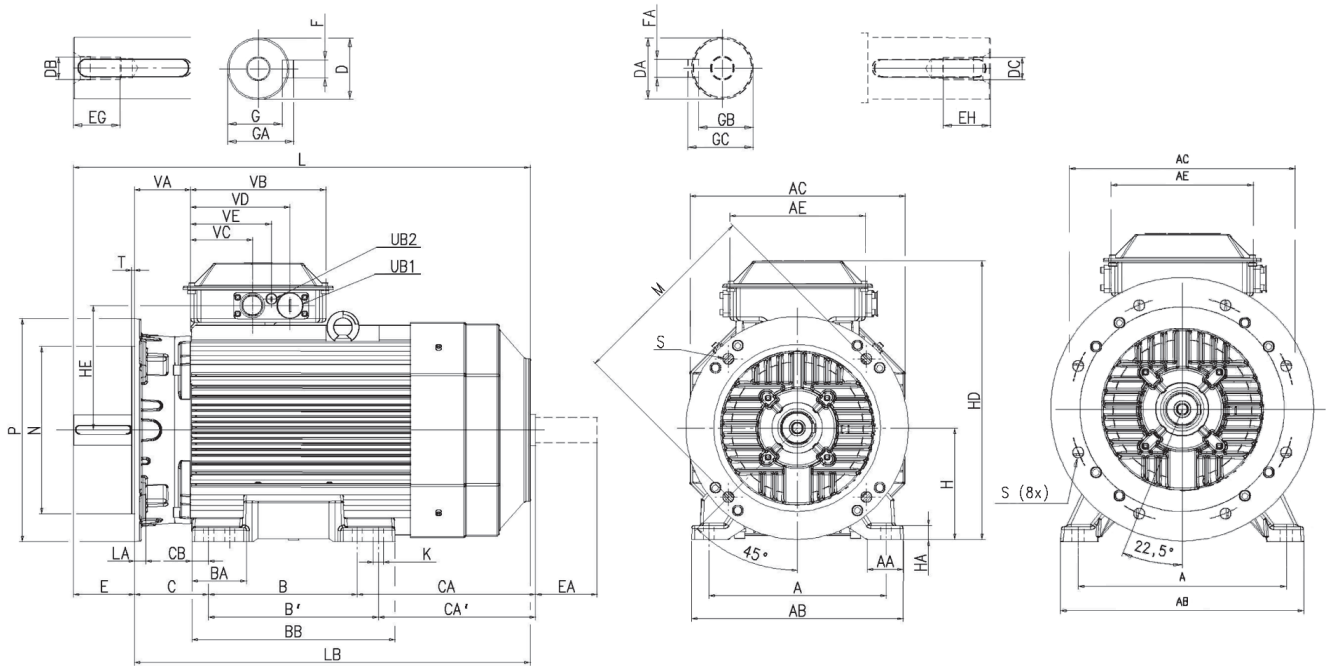

Foot- and flange-mounted motor; IM B35 (IM 2001), IM 2002 M3AA 200 M3AA 225

IM B35 (IM 2001), IM 2002

| Motor size | Poles | A | AA | AB | AC | AE | B | B' | BA | BB | C | CA | CA' | CB | D | DA | DB | DC | E ¹⁾ | EA |
|------------|-------|-----|----|-----|-----|-----|-----|-----|-----|-----|-----|-----|-----|------|----|----|-----|-----|-----------------|-----|
| 200 | | 318 | 64 | 380 | 386 | 243 | 267 | 305 | 112 | 365 | 133 | 314 | 276 | 30 | 55 | 45 | M20 | M16 | 110 | 110 |
| 225 | 2 | 356 | 69 | 418 | 425 | 243 | 286 | 311 | 102 | 365 | 149 | 314 | 289 | 24.5 | 55 | 55 | M20 | M20 | 110 | 110 |
| 225 | 4-8 | 356 | 69 | 418 | 425 | 243 | 286 | 311 | 102 | 365 | 149 | 314 | 289 | 24.5 | 60 | 55 | M20 | M20 | 140 | 110 |

| Motor size | Poles | EG | EH | F | FA | G | GA | GB | GC | H | HA | HD ³⁾ | HD ⁴⁾ | HE ³⁾ | HE ⁴⁾ | K | L | LA | LB | LC |
|------------|-------|----|----|----|----|----|----|------|------|-----|----|------------------|------------------|------------------|------------------|----|-----|----|-----|------|
| 200 | | 42 | 36 | 16 | 14 | 49 | 59 | 39.5 | 48.5 | 200 | 25 | 500 | 532 | 223 | 239 | 18 | 821 | 20 | 711 | 934 |
| 225 | 2 | 42 | 42 | 16 | 14 | 49 | 59 | 49 | 59 | 225 | 25 | 547 | 579 | 244 | 260 | 18 | 850 | 22 | 740 | 971 |
| 225 | 4-8 | 42 | 42 | 18 | 16 | 53 | 64 | 49 | 59 | 225 | 25 | 547 | 579 | 244 | 260 | 18 | 880 | 22 | 740 | 1001 |

| Motor size | Poles | M | N | P | S | T | UB ²⁾ | VA | VB | VC ³⁾ | VC ⁴⁾ | VD ³⁾ | VD ⁴⁾ | VE ³⁾ | VE ⁴⁾ |
|------------|-------|-----|-----|-----|----|---|------------------|------|-----|------------------|------------------|------------------|------------------|------------------|------------------|
| 200 | | 350 | 300 | 400 | 19 | 5 | 2xFL13 | 101 | 243 | 112 | 77 | 179 | 167 | 145 | 122 |
| 225 | 2 | 400 | 350 | 450 | 19 | 5 | 2xFL13 | 93.5 | 243 | 112 | 77 | 179 | 167 | 145 | 122 |
| 225 | 4-8 | 400 | 350 | 450 | 19 | 5 | 2xFL13 | 93.5 | 243 | 112 | 77 | 179 | 167 | 145 | 122 |

Tolerances

| | | |
|----------|----------|---------------------------------------------------------------------------------------------------------------------------------------------------------------------|
| A, B | ISO js14 | ¹⁾ Shoulder of shaft extension and contact surface of flange are in the same plane. |
| C, CA | ± 0.8 | ²⁾ Flange opening is provided with pipe flange FL 13, with tapped lead-in holes plugged with sealing plugs. Single- and two-speed motors: 2 x M40 + M16. |
| D 55-75 | ISO m6 | Motors for 230VD 50Hz or 225 SMC-2, 225 SMD-2, 225 SMD-4 have pipe flange FL21 and 2 x M63 + M16 |
| DA 45-55 | ISO k6 | |
| F, FA | ISO h9 | ³⁾ For flange opening FL13: 2 x M40 + M16 |
| H | +0 -0.5 | ⁴⁾ For extra large flange opening FL21: 2 x M63 + M16 |
| N | ISO j6 | |

Dimension drawings

Foot- and flange-mounted aluminum motors, 200 - 225, IE3 L generation

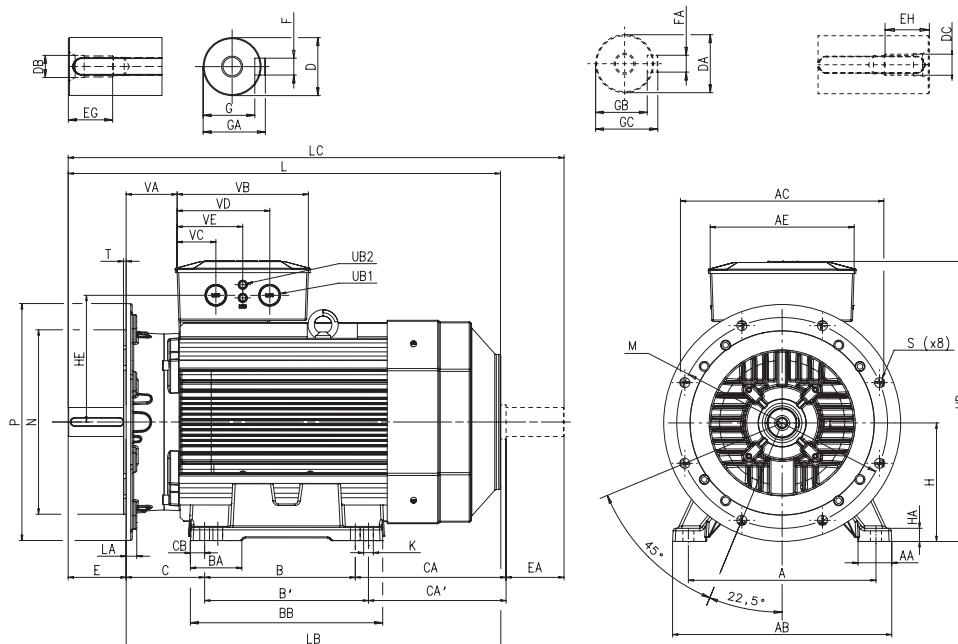

IMB35 (IM2001), IM 2002

| Motor size | Poles | Voltage code | A | AA | AB | AC | AE | B | B' | BA | BB | C | CA | CA' | CB | D | DA | DB | DC | E | EA |
|------------|-------|--------------|-----|----|-----|-----|-----|-----|-----|-----|-----|-----|-----|-----|----|----|----|-----|-----|-----|-----|
| 200 | | | 318 | 87 | 382 | 386 | 180 | 267 | 305 | 103 | 365 | 133 | 237 | 199 | 30 | 55 | 45 | M20 | M16 | 110 | 80 |
| 225 | 2 | D, E | 356 | 64 | 416 | 386 | 273 | 286 | 311 | 98 | 365 | 149 | 287 | 262 | 27 | 55 | 55 | M20 | M20 | 110 | 110 |
| 225 | 4-6 | D, E | 356 | 64 | 416 | 386 | 273 | 286 | 311 | 98 | 365 | 149 | 287 | 262 | 27 | 60 | 55 | M20 | M20 | 140 | 110 |
| 225 | 2 | S | 356 | 64 | 416 | 386 | 273 | 286 | 311 | 98 | 365 | 149 | 287 | 262 | 27 | 55 | 55 | M20 | M20 | 110 | 110 |
| 225 | 4-6 | S | 356 | 64 | 416 | 386 | 273 | 286 | 311 | 98 | 365 | 149 | 287 | 262 | 27 | 60 | 55 | M20 | M20 | 140 | 110 |

| Motor size | Poles | Voltage code | EG | EH | F | FA | G | GA | GB | GC | H | HA | HD | HE | K | L | LA | LB | LC |
|------------|-------|--------------|----|----|----|----|----|----|------|------|-----|----|-----|-----|----|-----|----|-----|-----|
| 200 | | | 42 | 36 | 16 | 14 | 49 | 59 | 39,5 | 48,5 | 200 | 25 | 425 | 154 | 15 | 726 | 20 | 616 | 815 |
| 225 | 2 | D, E | 42 | 42 | 16 | 14 | 49 | 59 | 49 | 59 | 225 | 25 | 531 | 241 | 18 | 821 | 20 | 711 | 942 |
| 225 | 4-6 | D, E | 42 | 42 | 18 | 16 | 53 | 64 | 49 | 59 | 225 | 25 | 531 | 241 | 18 | 851 | 20 | 711 | 972 |
| 225 | 2 | S | 42 | 42 | 16 | 14 | 49 | 59 | 49 | 59 | 225 | 25 | 531 | 241 | 18 | 821 | 20 | 711 | 942 |
| 225 | 4-6 | S | 42 | 42 | 18 | 16 | 53 | 64 | 49 | 59 | 225 | 25 | 531 | 241 | 18 | 851 | 20 | 711 | 972 |

| Motor size | Poles | Voltage code | M | N | P | S | T | UB1 | UB2 | VA | VB | VC | VD | VE |
|------------|-------|--------------|-----|-----|-----|----|---|-------|-------|------|-----|------|-------|-------|
| 200 | | | 300 | 250 | 350 | 19 | 5 | 2*M40 | M16 | 88,5 | 180 | 80 | 135,5 | 43 |
| 225 | 2 | D, E | 400 | 350 | 450 | 19 | 5 | 2*M40 | 2*M16 | 97 | 249 | 73,5 | 175,5 | 124,5 |
| 225 | 4-6 | D, E | 400 | 350 | 450 | 19 | 5 | 2*M40 | 2*M16 | 97 | 249 | 73,5 | 175,5 | 124,5 |
| 225 | 2 | S | 400 | 350 | 450 | 19 | 5 | 2*M63 | 2*M16 | 97 | 249 | 73,5 | 175,5 | 124,5 |
| 225 | 4-6 | S | 400 | 350 | 450 | 19 | 5 | 2*M63 | 2*M16 | 97 | 249 | 73,5 | 175,5 | 124,5 |

Tolerances

| | |
|----------|----------|
| A, B | ISO js14 |
| C, CA | ± 0.8 |
| D 55-65 | ISO m6 |
| DA 45-55 | ISO k6 |
| F, FA | ISO h9 |
| H | +0 -0.5 |
| N | ISO j6 |

Dimension drawings

Foot-mounted aluminum motors, 250 - 280

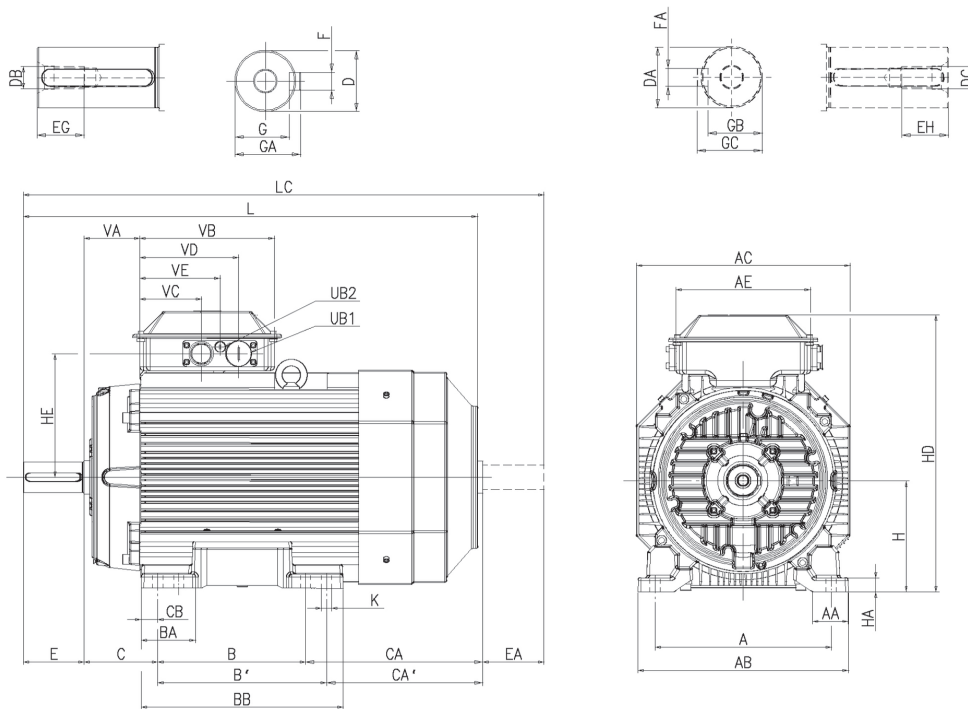

Foot-mounted motor; IM B3 (IM 1001), IM 1002

IM B3 (IM 1001), IM 1002

| Motor size | Poles | A | AA | AB | AC | AE | B | B' | BA | BB | C | CA | CA' | CB | D | DA | DB | DC | E | EA |
|------------|-------|-----|-------|-----|-----|-----|-----|-----|-----|-----|-----|-----|-----|------|----|----|-----|-----|-----|-----|
| 250 | 2 | 406 | 78 | 473 | 471 | 243 | 311 | 349 | 106 | 409 | 168 | 281 | 243 | 40 | 60 | 55 | M20 | M20 | 140 | 110 |
| 250 | 4-8 | 406 | 78 | 473 | 471 | 243 | 311 | 349 | 106 | 409 | 168 | 281 | 243 | 30 | 65 | 55 | M20 | M20 | 140 | 110 |
| 280 | 2 | 457 | 102.5 | 522 | 471 | 243 | 368 | 419 | 92 | 489 | 190 | 202 | 151 | 37.5 | 65 | 55 | M20 | M20 | 140 | 110 |
| 280 | 4-8 | 457 | 102.5 | 522 | 471 | 243 | 368 | 419 | 92 | 489 | 190 | 202 | 151 | 37.5 | 75 | 55 | M20 | M20 | 140 | 110 |

| Motor size | Poles | EG | EH | F | FA | G | GA | GB | GC | H | HA | HD ²⁾ | HD ³⁾ | HE ²⁾ | HE ³⁾ | K | L | LC | UB ¹⁾ | VA |
|------------|-------|----|----|----|----|------|------|----|----|-----|----|------------------|------------------|------------------|------------------|----|-----|------|------------------|------|
| 250 | 2 | 42 | 42 | 18 | 16 | 53 | 64 | 49 | 59 | 250 | 30 | 594 | 627 | 268 | 284 | 22 | 884 | 1010 | 2xFL13 | 93.5 |
| 250 | 4-8 | 42 | 42 | 18 | 16 | 58 | 69 | 49 | 59 | 250 | 30 | 594 | 627 | 268 | 284 | 22 | 884 | 1010 | 2xFL13 | 93.5 |
| 280 | 2 | 42 | 42 | 18 | 16 | 58 | 69 | 49 | 59 | 280 | 40 | - | 657 | - | 284 | 24 | 884 | 1010 | 2xFL21 | 93.5 |
| 280 | 4-8 | 42 | 42 | 20 | 16 | 67.5 | 79.5 | 49 | 59 | 280 | 40 | - | 657 | - | 284 | 24 | 884 | 1010 | 2xFL21 | 93.5 |

| Motor size | Poles | VB | VC ³⁾ | VC ⁴⁾ | VD ³⁾ | VD ⁴⁾ | VE ³⁾ | VE ⁴⁾ |
|------------|-------|-----|------------------|------------------|------------------|------------------|------------------|------------------|
| 250 | 2 | 243 | 112 | 77 | 179 | 167 | 145 | 122 |
| 250 | 4-8 | 243 | 112 | 77 | 179 | 167 | 145 | 122 |
| 280 | 2 | 243 | - | 77 | - | 167 | - | 122 |
| 280 | 4-8 | 243 | - | 77 | - | 167 | - | 122 |

| Tolerances | Footnotes |
|------------|-----------|
| A, B | ISO js14 |
| C, CA | ± 0.8 |
| D 55-75 | ISO m6 |
| DA 45-55 | ISO k6 |
| F, FA | ISO h9 |
| H | +0 -0.5 |

¹⁾ Flange opening is provided with pipe flange FL 13, with tapped lead-in holes plugged with sealing plugs. Single- and two-speed motors: 2 x M40 + M16.
 Motors for 230V 50Hz or 250 SMC-2, 250 SMC-4 and all 280 have pipe flange FL21 and 2 x M63 + M16
²⁾ For flange opening FL13: 2 x M40 + M16
³⁾ For extra large flange opening FL21: 2 x M63 + M16

Dimension drawings

Foot-mounted aluminum motors, 250 - 280, IE3 L generation

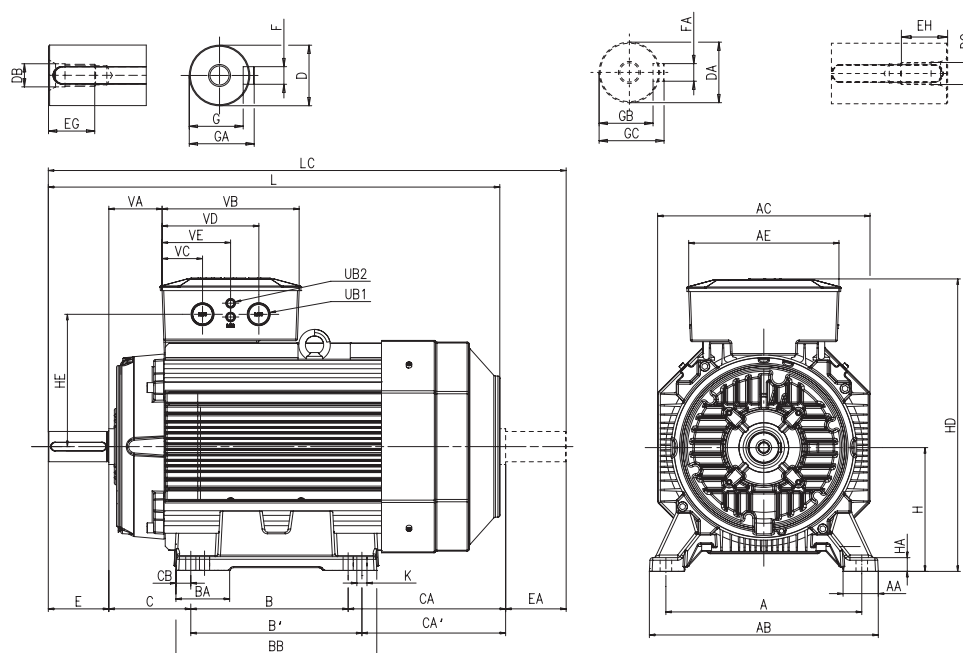

IM B3 (IM 1001), IM 1002

| Motor size | Poles | Voltage code | A | AA | AB | AC | AE | B | B' | BA | BB | C | CA | CA' | CB | D | DA | DB | DC | E | EA |
|------------|-------|--------------|-----|-----|-----|-----|-----|-----|-----|----|-----|-----|-----|-----|----|----|----|-----|-----|-----|-----|
| 250 | 2 | D, E | 406 | 76 | 472 | 425 | 273 | 311 | 349 | 84 | 409 | 168 | 277 | 239 | 30 | 60 | 55 | M20 | M20 | 140 | 110 |
| 250 | 4-6 | D, E | 406 | 76 | 472 | 425 | 273 | 311 | 349 | 84 | 409 | 168 | 277 | 239 | 30 | 65 | 55 | M20 | M20 | 140 | 110 |
| 250 | 2 | S | 406 | 76 | 472 | 425 | 273 | 311 | 349 | 84 | 409 | 168 | 277 | 239 | 30 | 60 | 55 | M20 | M20 | 140 | 110 |
| 250 | 4-6 | S | 406 | 76 | 472 | 425 | 273 | 311 | 349 | 84 | 409 | 168 | 277 | 239 | 30 | 65 | 55 | M20 | M20 | 140 | 110 |
| 280 | 2 | D, S, E | 457 | 102 | 522 | 471 | 273 | 368 | 419 | 92 | 489 | 190 | 202 | 151 | 37 | 65 | 55 | M20 | M20 | 140 | 110 |
| 280 | 4-6 | D, S, E | 457 | 102 | 522 | 471 | 273 | 368 | 419 | 92 | 489 | 190 | 202 | 151 | 37 | 75 | 55 | M20 | M20 | 140 | 110 |

| Motor size | Poles | Voltage code | EG | EH | F | FA | G | GA | GB | GC | H | HA | HD | HE | K | L | LC | UB1 | UB2 |
|------------|-------|--------------|----|----|----|----|------|------|----|----|-----|----|-----|-----|----|-----|------|-------|-------|
| 250 | 2 | D, E | 42 | 42 | 18 | 16 | 53 | 64 | 49 | 59 | 250 | 40 | 578 | 241 | 22 | 880 | 1006 | 2*M40 | 2*M16 |
| 250 | 4-6 | D, E | 42 | 42 | 18 | 16 | 58 | 69 | 49 | 59 | 250 | 40 | 578 | 241 | 22 | 880 | 1006 | 2*M40 | 2*M16 |
| 250 | 2 | S | 42 | 42 | 18 | 16 | 53 | 64 | 49 | 59 | 250 | 40 | 578 | 241 | 22 | 880 | 1006 | 2*M63 | 2*M16 |
| 250 | 4-6 | S | 42 | 42 | 18 | 16 | 58 | 69 | 49 | 59 | 250 | 40 | 578 | 241 | 22 | 880 | 1006 | 2*M63 | 2*M16 |
| 280 | 2 | D, S, E | 42 | 42 | 18 | 16 | 58 | 69 | 49 | 59 | 280 | 40 | 631 | 241 | 24 | 884 | 1010 | 2*M63 | 2*M16 |
| 280 | 4-6 | D, S, E | 42 | 42 | 20 | 16 | 67,5 | 79,5 | 49 | 59 | 280 | 40 | 631 | 241 | 24 | 884 | 1010 | 2*M63 | 2*M16 |

| Motor size | Poles | Voltage code | VA | VB | VC | VD | VE |
|------------|-------|--------------|----|-----|------|-------|-------|
| 250 | 2 | D, E | 90 | 249 | 73,5 | 175,5 | 124,5 |
| 250 | 4-6 | D, E | 90 | 249 | 73,5 | 175,5 | 124,5 |
| 250 | 2 | S | 90 | 249 | 73,5 | 175,5 | 124,5 |
| 250 | 4-6 | S | 90 | 249 | 73,5 | 175,5 | 124,5 |
| 280 | 2 | D, S, E | 90 | 249 | 73,5 | 175,5 | 124,5 |
| 280 | 4-6 | D, S, E | 90 | 249 | 73,5 | 175,5 | 124,5 |

Tolerances

| | |
|----------|----------|
| A, B | ISO js14 |
| C, CA | ± 0.8 |
| D 55-75 | ISO m6 |
| DA 45-55 | ISO k6 |
| F, FA | ISO h9 |
| H | +0 -0.5 |

Dimension drawings

Flange-mounted aluminum motors, 250 - 280

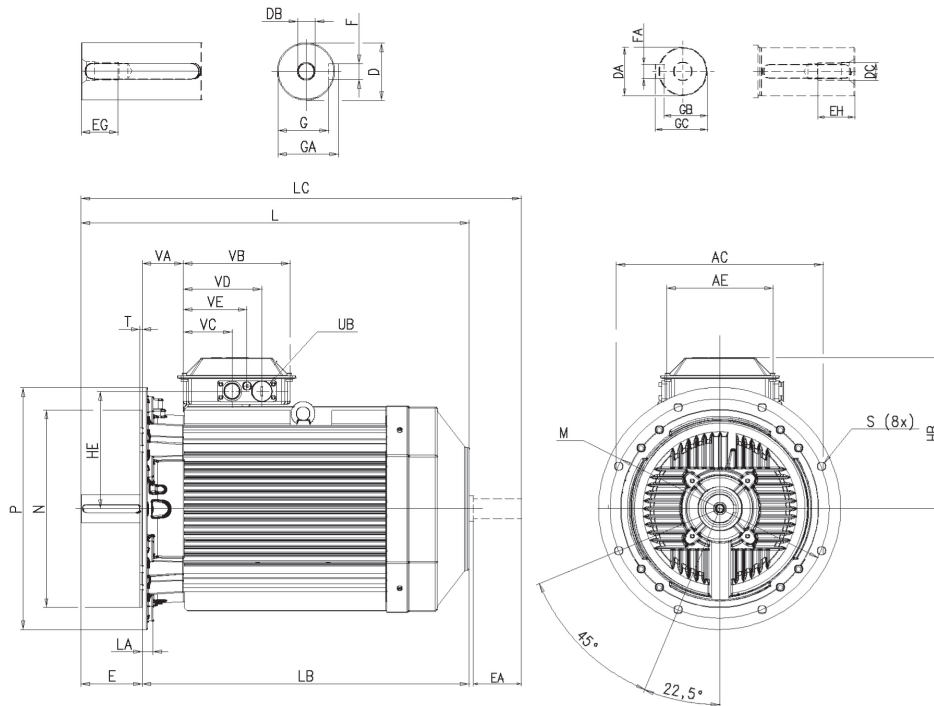

Flange-mounted motor; IM B5 (IM 3001), IM 3002

IM B5 (IM 3001), IM 3002

| Motor size | Poles | AC | AE | D | DA | DB | DC | E ¹⁾ | EA | EG | EH | F | FA | G | GA | GB | GC | HB ³⁾ | HB ⁴⁾ | HE ³⁾ | HE ⁴⁾ |
|------------|-------|-----|-----|----|----|-----|-----|-----------------|-----|----|----|----|----|------|------|----|----|------------------|------------------|------------------|------------------|
| 250 | 2 | 471 | 243 | 60 | 55 | M20 | M20 | 140 | 110 | 42 | 42 | 18 | 16 | 53 | 64 | 49 | 59 | 344 | 377 | 268 | 284 |
| 250 | 4-8 | 471 | 243 | 65 | 55 | M20 | M20 | 140 | 110 | 42 | 42 | 18 | 16 | 58 | 69 | 49 | 59 | 344 | 377 | 268 | 284 |
| 280 | 2 | 471 | 243 | 65 | 55 | M20 | M20 | 140 | 110 | 42 | 42 | 18 | 16 | 58 | 69 | 49 | 59 | - | 377 | - | 284 |
| 280 | 4-8 | 471 | 243 | 75 | 55 | M20 | M20 | 140 | 110 | 42 | 42 | 20 | 16 | 67.5 | 79.5 | 49 | 59 | - | 377 | - | 284 |

| Motor size | Poles | L | LA | LB | LC | M | N | P | S | T | UB ²⁾ | VA | VB | VC ³⁾ | VC ⁴⁾ | VD ³⁾ | VD ⁴⁾ | VE ³⁾ | VE ⁴⁾ |
|------------|-------|-----|----|-----|------|-----|-----|-----|----|---|------------------|------|-----|------------------|------------------|------------------|------------------|------------------|------------------|
| 250 | 2 | 884 | 24 | 744 | 1010 | 500 | 450 | 550 | 19 | 5 | 2xFL13 | 93.5 | 243 | 112 | 77 | 179 | 167 | 145 | 122 |
| 250 | 4-8 | 884 | 24 | 744 | 1010 | 500 | 450 | 550 | 19 | 5 | 2xFL13 | 93.5 | 243 | 112 | 77 | 179 | 167 | 145 | 122 |
| 280 | 2 | 884 | 24 | 744 | 1010 | 500 | 450 | 550 | 19 | 5 | 2xFL21 | 93.5 | 243 | - | 77 | - | 167 | - | 122 |
| 280 | 4-8 | 884 | 24 | 744 | 1010 | 500 | 450 | 550 | 19 | 5 | 2xFL21 | 93.5 | 243 | - | 77 | - | 167 | - | 122 |

Tolerances

| | |
|----------|--------|
| D 55-75 | ISO m6 |
| DA 45-55 | ISO k6 |
| F, FA | ISO h9 |
| N | ISO j6 |

Footnotes

- ¹⁾ Shoulder of shaft extension and contact surface of flange are in the same plane.
- ²⁾ Flange opening is provided with pipe flange FL 13, with tapped lead-in holes plugged with sealing plugs. Single- and two-speed motors: 2 x M40 + M16. Motors for 230VD 50Hz or 250 SMC-2, 250 SMC-4 and all 280 have pipe flange FL21 and 2 x M63 + M16
- ³⁾ For flange opening FL13: 2 x M40 + M16
- ⁴⁾ For extra large flange opening FL21: 2 x M63 + M16

Dimension drawings

Flange-mounted aluminum motors, 250 - 280, IE3 L generation

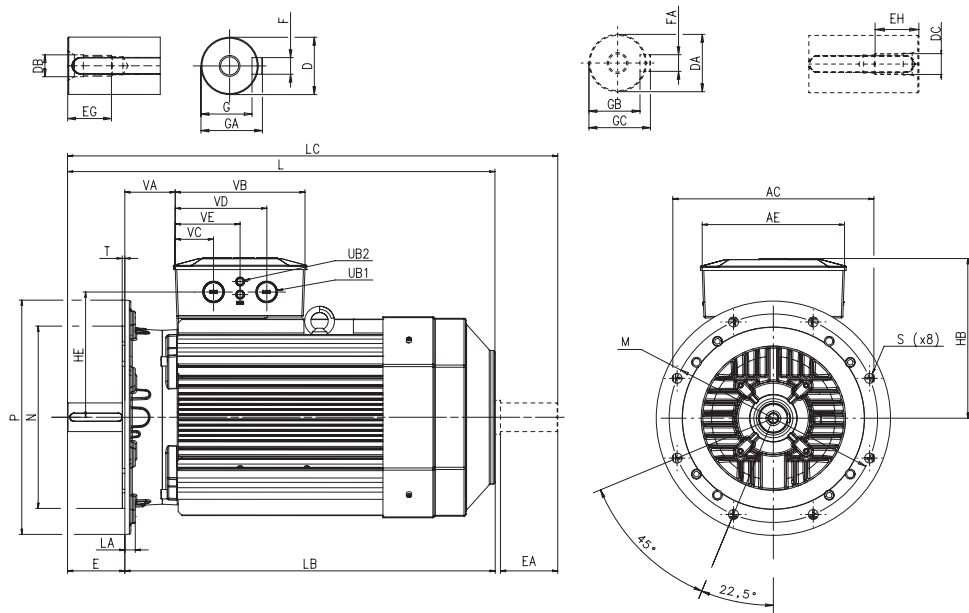

IM B5 (IM 3001), IM 3002

| Motor size | Poles | Voltage code | AC | AE | D | DA | DB | DC | E | EA | EG | EH | F | FA | G | GA | GB | GC |
|------------|-------|--------------|-----|-----|----|----|-----|-----|-----|-----|----|----|----|----|------|------|----|----|
| 250 | 2 | D, E | 425 | 273 | 60 | 55 | M20 | M20 | 140 | 110 | 42 | 42 | 18 | 16 | 53 | 64 | 49 | 59 |
| 250 | 4-6 | D, E | 425 | 273 | 65 | 55 | M20 | M20 | 140 | 110 | 42 | 42 | 18 | 16 | 58 | 69 | 49 | 59 |
| 250 | 2 | S | 425 | 273 | 60 | 55 | M20 | M20 | 140 | 110 | 42 | 42 | 18 | 16 | 53 | 64 | 49 | 59 |
| 250 | 4-6 | S | 425 | 273 | 65 | 55 | M20 | M20 | 140 | 110 | 42 | 42 | 18 | 16 | 58 | 69 | 49 | 59 |
| 280 | 2 | D, S, E | 471 | 273 | 65 | 55 | M20 | M20 | 140 | 110 | 42 | 42 | 18 | 16 | 58 | 69 | 49 | 59 |
| 280 | 4-6 | D, S, E | 471 | 273 | 75 | 55 | M20 | M20 | 140 | 110 | 42 | 42 | 20 | 16 | 67,5 | 79,5 | 49 | 59 |

| Motor size | Poles | Voltage code | HE | L | LA | LB | LC | M | N | P | S | T | UB1 | UB2 | VA | VB | VC | VD | VE |
|------------|-------|--------------|-----|-----|----|-----|------|-----|-----|-----|----|---|-------|-------|----|-----|------|-------|-------|
| 250 | 2 | D, E | 241 | 880 | 22 | 740 | 1006 | 500 | 450 | 550 | 19 | 5 | 2*M40 | 2*M16 | 90 | 249 | 73,5 | 175,5 | 124,5 |
| 250 | 4-6 | D, E | 241 | 880 | 22 | 740 | 1006 | 500 | 450 | 550 | 19 | 5 | 2*M40 | 2*M16 | 90 | 249 | 73,5 | 175,5 | 124,5 |
| 250 | 2 | S | 241 | 880 | 22 | 740 | 1006 | 500 | 450 | 550 | 19 | 5 | 2*M63 | 2*M16 | 90 | 249 | 73,5 | 175,5 | 124,5 |
| 250 | 4-6 | S | 241 | 880 | 22 | 740 | 1006 | 500 | 450 | 550 | 19 | 5 | 2*M63 | 2*M16 | 90 | 249 | 73,5 | 175,5 | 124,5 |
| 280 | 2 | D, S, E | 241 | 884 | 25 | 744 | 1010 | 500 | 450 | 550 | 19 | 5 | 2*M63 | 2*M16 | 90 | 249 | 73,5 | 175,5 | 124,5 |
| 280 | 4-6 | D, S, E | 241 | 884 | 25 | 744 | 1010 | 500 | 450 | 550 | 19 | 5 | 2*M63 | 2*M16 | 90 | 249 | 73,5 | 175,5 | 124,5 |

Tolerances

| | |
|----------|--------|
| D 55-75 | ISO m6 |
| DA 45-55 | ISO k6 |
| F, FA | ISO h9 |
| N | ISO j6 |

Dimension drawings

Foot- and flange-mounted aluminum motors, 250 - 280

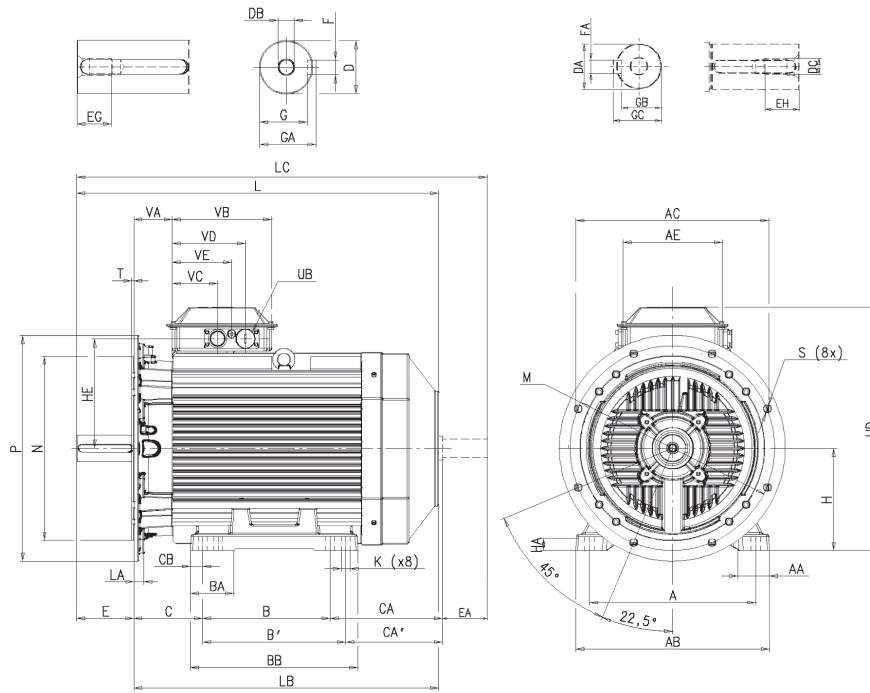

Foot- and flange-mounted motor; IM B35 (IM 2001), IM 2002

IM B35 (IM 2001), IM 2002

| Motor size | Poles | A | AA | AB | AC | AE | B | B' | BA | BB | C | CA | CA' | CB | D | DA | DB | DC | E ¹⁾ | EA | EG | EH | F |
|------------|-------|-----|-----|-----|-----|-----|-----|-----|-----|-----|-----|-----|-----|----|----|----|-----|-----|-----------------|-----|----|----|----|
| 250 | 2 | 406 | 78 | 474 | 471 | 243 | 311 | 349 | 106 | 409 | 168 | 281 | 243 | 40 | 60 | 55 | M20 | M20 | 140 | 110 | 42 | 42 | 18 |
| 250 | 4-8 | 406 | 78 | 474 | 471 | 243 | 311 | 349 | 106 | 409 | 168 | 281 | 243 | 30 | 65 | 55 | M20 | M20 | 140 | 110 | 42 | 42 | 18 |
| 280 | 2 | 457 | 103 | 525 | 471 | 243 | 368 | 419 | 92 | 489 | 190 | 202 | 151 | 38 | 65 | 55 | M20 | M20 | 140 | 110 | 42 | 42 | 18 |
| 280 | 4-8 | 457 | 103 | 525 | 471 | 243 | 368 | 419 | 92 | 489 | 190 | 202 | 151 | 38 | 75 | 55 | M20 | M20 | 140 | 110 | 42 | 42 | 20 |

| Motor size | Poles | FA | G | GA | GB | GC | H | HA | HD ³⁾ | HD ⁴⁾ | HE ³⁾ | HE ⁴⁾ | K | L | LA | LB | LC | M | N | P | S | T | UB ²⁾ |
|------------|-------|----|----|----|----|----|-----|----|------------------|------------------|------------------|------------------|----|-----|----|-----|------|-----|-----|-----|----|---|------------------|
| 250 | 2 | 16 | 53 | 64 | 49 | 59 | 250 | 30 | 594 | 627 | 268 | 284 | 22 | 884 | 24 | 744 | 1010 | 500 | 450 | 550 | 19 | 5 | 2xFL13 |
| 250 | 4-8 | 16 | 58 | 69 | 49 | 59 | 250 | 30 | 594 | 627 | 268 | 284 | 22 | 884 | 24 | 744 | 1010 | 500 | 450 | 550 | 19 | 5 | 2xFL13 |
| 280 | 2 | 16 | 58 | 69 | 49 | 59 | 280 | 40 | - | 657 | - | 284 | 24 | 884 | 24 | 744 | 1010 | 500 | 450 | 550 | 19 | 5 | 2xFL21 |
| 280 | 4-8 | 16 | 68 | 80 | 49 | 59 | 280 | 40 | - | 657 | - | 284 | 24 | 884 | 24 | 744 | 1010 | 500 | 450 | 550 | 19 | 5 | 2xFL21 |

| Motor size | Poles | VA | VB | VC ³⁾ | VC ⁴⁾ | VD ³⁾ | VD ⁴⁾ | VE ³⁾ | VE ⁴⁾ |
|------------|-------|----|-----|------------------|------------------|------------------|------------------|------------------|------------------|
| 250 | 2 | 93 | 243 | 112 | 77 | 179 | 167 | 145 | 122 |
| 250 | 4-8 | 93 | 243 | 112 | 77 | 179 | 167 | 145 | 122 |
| 280 | 2 | 93 | 243 | - | 77 | - | 167 | - | 122 |
| 280 | 4-8 | 93 | 243 | - | 77 | - | 167 | - | 122 |

Tolerances

| | |
|----------|----------|
| A, B | ISO js14 |
| C, CA | ± 0.8 |
| D 55-75 | ISO m6 |
| DA 45-55 | ISO k6 |
| F, FA | ISO h9 |
| H | +0 -0.5 |
| N | ISO js6 |

Footnotes

- ¹⁾ Shoulder of shaft extension and contact surface of flange are in the same plane.
- ²⁾ Flange opening is provided with pipe flange FL 13, with tapped lead-in holes plugged with sealing plugs. Single- and two-speed motors: 2 x M40 + M16. Motors for 230VD 50Hz or 250 SMC-2, 250 SMC-4 and all 280 have pipe flange FL21 and 2 x M63 + M16
- ³⁾ For flange opening FL13: 2 x M40 + M16
- ⁴⁾ For extra large flange opening FL21: 2 x M63 + M16

Dimension drawings

Foot- and flange-mounted aluminum motors, 250 - 280, IE3 L generation

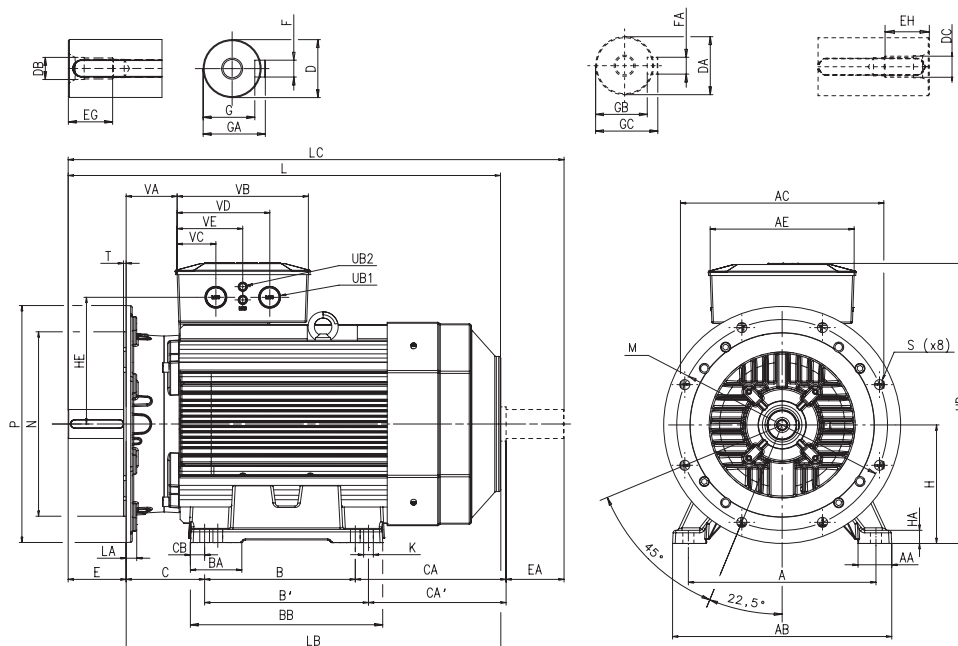

IM B35 (IM 2001), IM 2002

| Motor size | Poles | Voltage code | A | AA | AB | AC | AE | B | B' | BA | BB | C | CA | CA' | CB | D | DA | DB | DC | E | EA |
|------------|-------|--------------|-----|-----|-----|-----|-----|-----|-----|----|-----|-----|-----|-----|----|----|----|-----|-----|-----|-----|
| 250 | 2 | D, E | 406 | 76 | 472 | 425 | 273 | 311 | 349 | 84 | 409 | 168 | 277 | 239 | 30 | 60 | 55 | M20 | M20 | 140 | 110 |
| 250 | 4-6 | D, E | 406 | 76 | 472 | 425 | 273 | 311 | 349 | 84 | 409 | 168 | 277 | 239 | 30 | 65 | 55 | M20 | M20 | 140 | 110 |
| 250 | 2 | S | 406 | 76 | 472 | 425 | 273 | 311 | 349 | 84 | 409 | 168 | 277 | 239 | 30 | 60 | 55 | M20 | M20 | 140 | 110 |
| 250 | 4-6 | S | 406 | 76 | 472 | 425 | 273 | 311 | 349 | 84 | 409 | 168 | 277 | 239 | 30 | 65 | 55 | M20 | M20 | 140 | 110 |
| 280 | 2 | D, S, E | 457 | 102 | 522 | 471 | 273 | 368 | 419 | 92 | 489 | 190 | 202 | 151 | 37 | 65 | 55 | M20 | M20 | 140 | 110 |
| 280 | 4-6 | D, S, E | 457 | 102 | 522 | 471 | 273 | 368 | 419 | 92 | 489 | 190 | 202 | 151 | 37 | 75 | 55 | M20 | M20 | 140 | 110 |

| Motor size | Poles | Voltage code | EG | EH | F | FA | G | GA | GB | GC | H | HA | HD | HE | K | L | LA | LB | LC |
|------------|-------|--------------|----|----|----|----|------|------|----|----|-----|----|-----|-----|----|-----|----|-----|------|
| 250 | 2 | D, E | 42 | 42 | 18 | 16 | 53 | 64 | 49 | 59 | 250 | 40 | 578 | 241 | 22 | 880 | 22 | 740 | 1006 |
| 250 | 4-6 | D, E | 42 | 42 | 18 | 16 | 58 | 69 | 49 | 59 | 250 | 40 | 578 | 241 | 22 | 880 | 22 | 740 | 1006 |
| 250 | 2 | S | 42 | 42 | 18 | 16 | 53 | 64 | 49 | 59 | 250 | 40 | 578 | 241 | 22 | 880 | 22 | 740 | 1006 |
| 250 | 4-6 | S | 42 | 42 | 18 | 16 | 58 | 69 | 49 | 59 | 250 | 40 | 578 | 241 | 22 | 880 | 22 | 740 | 1006 |
| 280 | 2 | D, S, E | 42 | 42 | 18 | 16 | 58 | 69 | 49 | 59 | 280 | 40 | 631 | 241 | 24 | 884 | 25 | 744 | 1010 |
| 280 | 4-6 | D, S, E | 42 | 42 | 20 | 16 | 67,5 | 79,5 | 49 | 59 | 280 | 40 | 631 | 241 | 24 | 884 | 25 | 744 | 1010 |

| Motor size | Poles | Voltage code | M | N | P | S | T | UB1 | UB2 | VA | VB | VC | VD | VE |
|------------|-------|--------------|-----|-----|-----|----|---|-------|-------|----|-----|------|-------|-------|
| 250 | 2 | D, E | 500 | 450 | 550 | 19 | 5 | 2*M40 | 2*M16 | 90 | 249 | 73,5 | 175,5 | 124,5 |
| 250 | 4-6 | D, E | 500 | 450 | 550 | 19 | 5 | 2*M40 | 2*M16 | 90 | 249 | 73,5 | 175,5 | 124,5 |
| 250 | 2 | S | 500 | 450 | 550 | 19 | 5 | 2*M63 | 2*M16 | 90 | 249 | 73,5 | 175,5 | 124,5 |
| 250 | 4-6 | S | 500 | 450 | 550 | 19 | 5 | 2*M63 | 2*M16 | 90 | 249 | 73,5 | 175,5 | 124,5 |
| 280 | 2 | D, S, E | 500 | 450 | 550 | 19 | 5 | 2*M63 | 2*M16 | 90 | 249 | 73,5 | 175,5 | 124,5 |
| 280 | 4-6 | D, S, E | 500 | 450 | 550 | 19 | 5 | 2*M63 | 2*M16 | 90 | 249 | 73,5 | 175,5 | 124,5 |

Tolerances

| | |
|----------|----------|
| A, B | ISO js14 |
| C, CA | ± 0.8 |
| D 55-65 | ISO m6 |
| DA 45-55 | ISO k6 |
| F, FA | ISO h9 |
| H | +0 -0.5 |
| N | ISO js6 |

Accessories

Slide rails for motor sizes 160 to 280

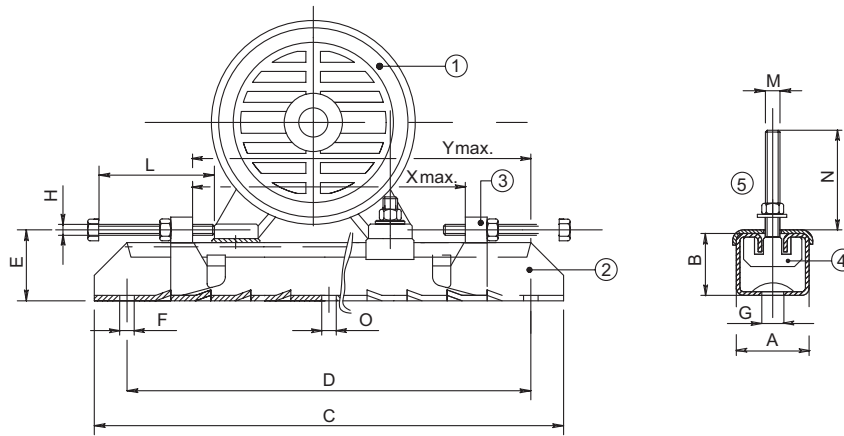

1 Motor | 2 Rail | 3 Movable adjusting bolt | 4 Fixing bolt, motor | 5 Plate

| Motor size | Type | Product code 3GZV103001- | A | B | C | D | E | F | G | H | L | M | N | O | Xmax | Ymax | Weight (kg) |
|------------|----------|-----------------------------|-----|----|------|------|----|----|----|-----|-----|-----|----|----|------|------|----------------|
| 160-180 | TT180/12 | -14 | 75 | 42 | 700 | 630 | 57 | 17 | 26 | M12 | 120 | M12 | 50 | - | 520 | 580 | 12.0 |
| 200-225 | TT225/16 | -15 | 82 | 50 | 864 | 800 | 68 | 17 | 27 | M16 | 140 | M16 | 65 | 17 | 670 | 740 | 20.4 |
| 250-280 | TT280/20 | -16 | 116 | 70 | 1072 | 1000 | 90 | 20 | 27 | M18 | 150 | M20 | 80 | 20 | 870 | 940 | 43.0 |

¹⁾ Smaller sizes on request.

Each set includes two complete slide rails including screw for mounting the motor on the rails. Screws for mounting the rails on the foundation are not included. Slide rails are supplied with unmachined lower surfaces and should, prior to tightening down, be supported in a suitable manner.

Motors in brief

IE2/IE3 aluminum motors, sizes 63 - 132

| Size | M3AA | 63 | 71 | 80 | 90 | 100 | 112 | 132 |
|-------------------------|--------------------|-----------------------------------------------------------|---------------|------------|-------------------|------------|------------------------------------------------------------|-----------------------------------------------------------------------|
| Stator and end shields | Material | Die-cast aluminum alloy | | | | | | |
| | Paint color shade | Munsell blue 8B 4.5/3.25 | | | | | | |
| | Corrosion class | C3 medium according to ISO/EN 12944-5 | | | | | | |
| Feet | Material | Integrated aluminum feet | | | | | | |
| End shields | Material | Die-cast aluminum alloy | | | | | | |
| | Paint color shade | Munsell blue 8B 4.5/3.25 | | | | | | |
| | Corrosion class | C3 medium according to ISO/EN 12944-5 | | | | | | |
| Bearings | D-end | 6202-2Z/C3 | 6203-2Z/C3 | 6204-2Z/C3 | 6205-2Z/C3 | 6306-2Z/C3 | 6306-2Z/C3 | 6208-2Z/C3 6206-2Z/C3 (112 J-gen) 6308-2Z/C3 (SM _L) |
| | N-end | 6201-2Z/C3 | 6202-2C/C3 | 6203-2Z/C3 | 6204-2Z/C3 | 6205-2Z/C3 | 6205-2Z/C3 | 6206-2Z/C3 |
| Axially locked bearings | | Locked at D-end with internal retaining ring | | | Locked at D-end | | | |
| Bearing seals | D-end | V-ring | | | | | | |
| | N-end | Labyrinth seal | | | | | | |
| Lubrication | | Permanently lubricated shielded bearing | | | | | | |
| | | Grease temperature range -40 °C to +160 °C | | | | | | |
| Measuring nipples | | Not included | | | | | | |
| Rating plate | Material | Aluminum | | | | | | |
| Terminal box | Frame and cover | Die-cast aluminum alloy, integrated in stator | | | | | | |
| | Corrosion class | C3 medium according to ISO/EN 12944-5 | | | | | | |
| | Cover screws | Zinc-electroplated steel | | | | | | |
| Connections | Knock-out openings | 1xM16xPg11 | 2x(M20 + M20) | | 2x(M20+M25) | | 2x(M20+M25) ¹⁾ 2x(M40+M32+M12) ²⁾ | |
| | Terminal box | Cable lugs, 6 terminals | | | 6 screw terminals | | Cable lugs, 6 terminals | |
| Fan | Material | Glass-fiber reinforced polypropylene | | | | | | |
| Fan cover | Material | Polypropylene | | | | | | |
| Stator winding | Material | Copp | | | | | | |
| | Insulation | Insulation class F | | | | | | |
| | Winding protection | Optional | | | | | | |
| Rotor winding | Material | Die-cast aluminum | | | | | | |
| Balancing method | | Half-key balancin | | | | | | |
| Keyway | | Closed keyway | | | | | | |
| Drain holes | | Drain holes with closable plastic plugs, open on delivery | | | | | | |
| Enclosure | | IP 55 | | | | | | |
| Cooling method | | IC 411 | | | | | | |

¹⁾ Types S, SB, M, MA

²⁾ Types SC, MC, SMA - SME

Motors in brief

IE2/IE3 aluminum motors, sizes 160 - 280

| Size | M3AA | 160 | 180 | 200 | 225 | 250 | 280 |
|-------------------------|--------------------|-----------------------------------------------------------|------------|------------------------------------------|------------|------------|-----------------------|
| Stator | Material | Die-cast aluminum alloy | | Extruded aluminum alloy | | | |
| | Paint color shade | Munsell blue 8B 4.5/3.25 | | | | | |
| | Corrosion class | C3 medium according to ISO/EN 12944-5 | | | | | |
| Feet | Material | Separate aluminum feet | | Separate cast iron feet | | | |
| End shields | Material | Cast iron | | | | | |
| | Paint color shade | Munsell blue 8B 4.5/3.25 | | | | | |
| | Corrosion class | C3 medium according to ISO/EN 12944-5 | | | | | |
| Bearings | D-end | 6309-2Z/C3 | 6310-2Z/C3 | 6312-2Z/C3 | 6313-2Z/C3 | 6315-2Z/C3 | 6316/C3 ¹⁾ |
| | N-end | 6209-2Z/C3 | 6209-2Z/C3 | 6210-2Z/C3 | 6212-2Z/C3 | 6213-2Z/C3 | 6213/C3 |
| Axially locked bearings | | Locked at D-end | | | | | |
| Bearing seals | | Axial seal at both ends | | | | | |
| Lubrication | | Permanently lubricated shielded bearings | | | | | |
| | | Grease temperature range -40 °C to +160 °C | | | | | |
| Measuring nipples | | Not included | | | | | |
| Rating plate | Material | Aluminum | | | | | |
| Terminal box | Material | Die-cast aluminum alloy, integrated in stator | | Deep-drawn steel sheet, bolted to stator | | | |
| | Corrosion class | C3 medium according to ISO/EN 12944- | | | | | |
| | Cover screws | Zinc-electroplated steel | | | | | |
| Connections | Openings | (2xM40 + M16) + (2xM40) | | 2xFL13, 2xM40 + 1xM16 | | | 2xFL21 |
| | | Type: knock-outs | | Voltage code S; 2xFL21, 2xM63 + 1xM16 | | | 2xM63, 1xM16 |
| | Screws | M6 | | M10 | | | |
| | Terminal box | 6 terminals for connection with cable lugs (not included) | | | | | |
| Fan | Material | Glass-fiber reinforced polypropylene | | | | | |
| Fan cover | Material | Steel | | | | | |
| | Paint color shade | Munsell blue 8B 4.5/3.25 | | | | | |
| | Corrosion class | C3 medium according to ISO/EN 12944-5 | | | | | |
| Stator winding | Material | Copper | | | | | |
| | Insulation | Insulation class F | | | | | |
| | Winding protection | 3 PTC thermistors, 150 °C | | | | | |
| Rotor winding | Material | Die-cast aluminum | | | | | |
| Balancing method | | Half-key balancing | | | | | |
| Keyway | | Closed keyway | | | | | |
| Drain holes | | Drain holes with closable plastic plugs, open on delivery | | | | | |
| Enclosure | | IP 55 | | | | | |
| Cooling method | | IC 411 | | | | | |

¹⁾ 6315/C3 for 2-pole motors

Total product offering

Motors, generators and mechanical power transmission products with a complete portfolio of services



ABB is the leading manufacturer of low, medium and high voltage motors and generators, and mechanical power transmission products. ABB products are backed by a complete portfolio of services. Our in-depth knowledge of virtually every type of industrial process ensures we always specify the best solution for your needs.

Low and high voltage IEC induction motors

- Process performance motors
- General performance motors
- High voltage cast iron motors
- Induction modular motors
- Slip-ring modular motors

Low and medium voltage NEMA motors

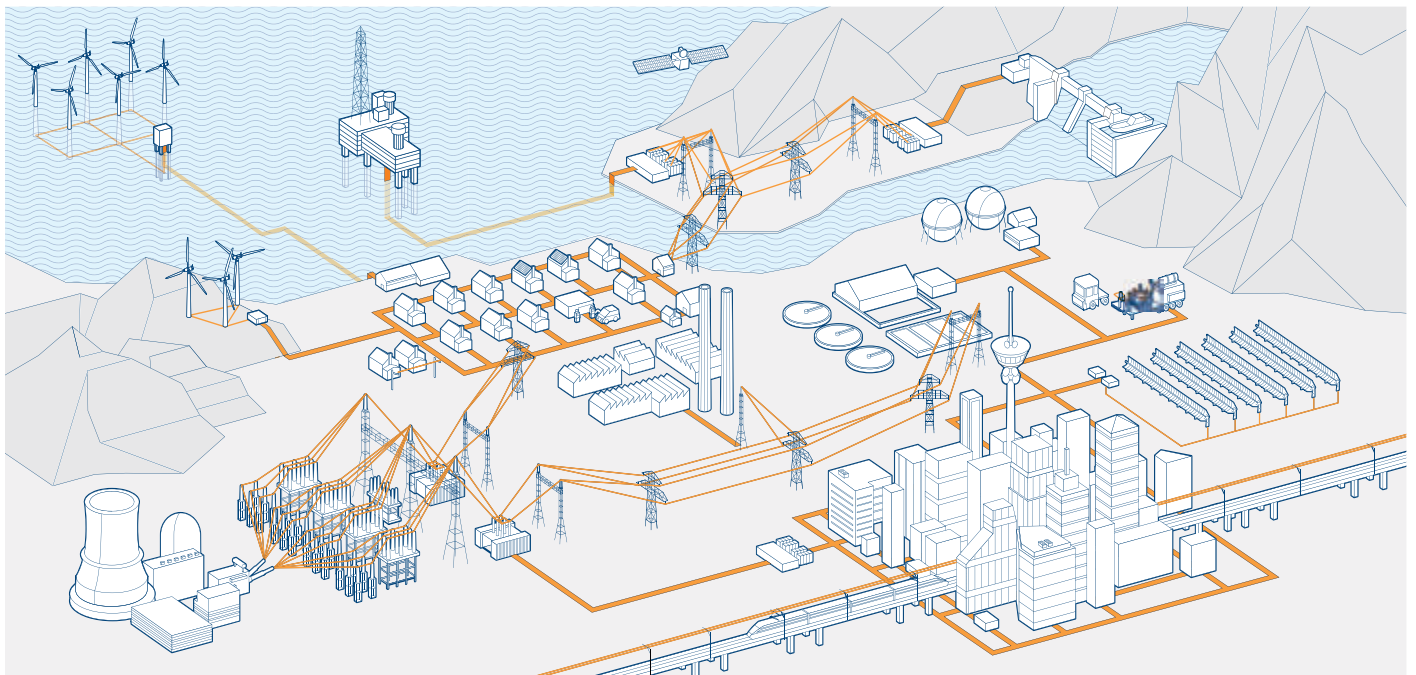
- Steel frame open drip proof (ODP) motors
- Weather protected, water cooled, fan ventilated
- Cast iron frame (TEFC)
- Air to air cooled (TEAAC) motors

Motors and generators for explosive atmospheres

- IEC and NEMA motors and generators, for all protection types

Synchronous motors

Synchronous generators

- Synchronous generators for diesel and gas engines
- Synchronous generators for steam and gas turbines

Wind power generators

Generators for small hydro

Other motors and generators

- Brake motors
- DC motors and generators
- Gear motors
- Marine motors and generators
- Single phase motors
- Motors for high ambient temperatures
- Synchronous reluctance motors
- Permanent magnet motors and generators
- High speed motors
- Smoke extraction motors
- Wash down motors
- Water cooled motors
- Generator sets
- Roller table motors
- Low inertia motors
- Traction motors and generators

Life cycle services

Mechanical power transmission components, bearings, gearings

Life cycle services and support

From pre-purchase to migration and upgrades



ABB offers a complete portfolio of services to ensure trouble-free operation and long product lifetimes. These services cover the entire life cycle. Local support is provided through a global network of ABB service centers and certified partners.

Pre-purchase

ABB's front-end sales organization can help customers to quickly and efficiently select, configure and optimize the right motor or generator for their application.

Installation and commissioning

Professional installation and commissioning by ABB's certified engineers represent an investment in availability and reliability over the entire life cycle.

Engineering and consulting

ABB's experts provide energy efficiency and reliability appraisals, advanced condition and performance assessments and technical studies.

Condition monitoring and diagnosis

Unique services collect and analyze data to provide early warnings of problems before failures can occur. All critical areas of the equipment are covered.

Maintenance and field services

ABB offers life cycle management plans and preventive maintenance products. The recommended four-level maintenance program covers the entire product lifetime.

Spare parts

Spare parts and support are offered throughout the life cycle of ABB products. In addition to individual spares, tailored spare part packages are also available.

Repair and refurbishment

Support for all ABB motors and generators and other brands is provided by ABB's global service organization. Specialist teams can also deliver emergency support.

Migration and upgrades

Life cycle audits determine the optimum upgrades and migration paths. Upgrades range from individual components to direct replacement motors and generators.

Training

Product and service training courses take a practical approach. The training ranges from standard courses to specially tailored programs to suit customer requirements.

Specialized support

Specialized support is offered through ABB's global service organization. Local units provide major and minor repairs as well as overhauls and reconditioning.

Service contracts

Service contracts are tailored to the customer's needs. The contracts combine ABB's entire service portfolio and 120 years of experience to deploy the optimal service practices.

Contact us

www.abb.com/motors&generators

We reserve the right to make technical changes or modify the contents of this document without prior notice. With regard to purchase orders, the agreed particulars shall prevail. ABB does not accept any responsibility what so ever for potential errors or possible lack of information in this document.

We reserve all rights in this document and in the subject matter and illustrations contained herein. Any reproduction, disclosure to third parties or utilization of its contents – in whole or in parts – is forbidden without prior written consent of ABB.

© Copyright 2015 ABB.

All rights reserved.

